



DEVELOPMENTS IN
PETROLEUM SCIENCE

52

GEOLOGY AND GEOCHEMISTRY OF OIL AND GAS

G.V. CHILINGAR, L.A. BURYAKOVSKY,
N.A. EREMENKO & M.V. GORFUNKEL

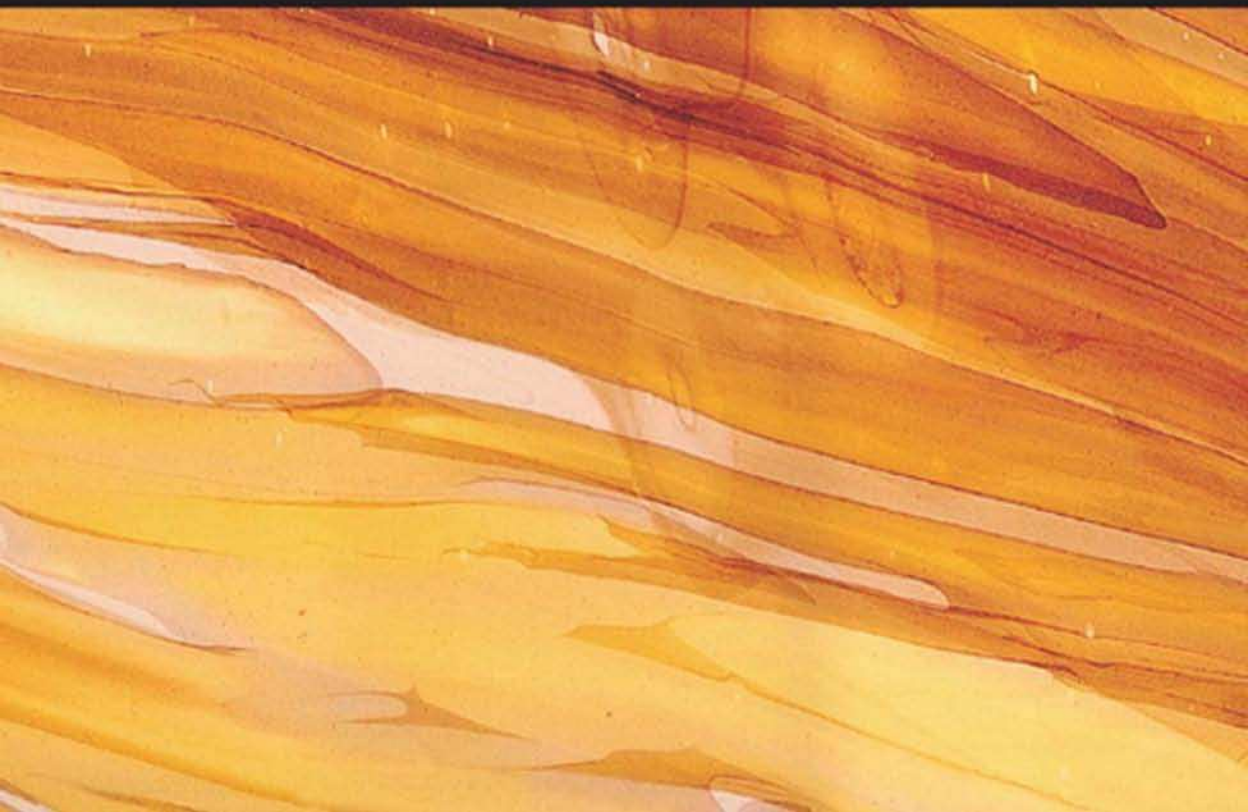



DEVELOPMENTS IN PETROLEUM SCIENCE 52

GEOLOGY AND GEOCHEMISTRY OF OIL AND GAS

DEVELOPMENTS IN PETROLEUM SCIENCE 52

Volumes 1-7, 9-18, 19b, 20-29, 31, 34, 35, 37-39 are out of print.

8	Fundamentals of Reservoir Engineering
19a	Surface Operations in Petroleum Production, I
30	Carbonate Reservoir Characterization: A Geologic-Engineering Analysis, Part I
32	Fluid Mechanics for Petroleum Engineers
33	Petroleum Related Rock Mechanics
36	The Practice of Reservoir Engineering (Revised Edition)
40a	Asphaltenes and Asphalts, I
40b	Asphaltenes and Asphalts, II
41	Subsidence due to Fluid Withdrawal
42	Casing Design – Theory and Practice
43	Tracers in the Oil Field
44	Carbonate Reservoir Characterization: A Geologic-Engineering Analysis, Part II
45	Thermal Modeling of Petroleum Generation: Theory and Applications
46	Hydrocarbon Exploration and Production
47	PVT and Phase Behaviour of Petroleum Reservoir Fluids
48	Applied Geothermics for Petroleum Engineers
49	Integrated Flow Modeling
50	Origin and Prediction of Abnormal Formation Pressures
51	Soft Computing and Intelligent Data Analysis in Oil Exploration
52	Geology and Geochemistry of Oil and Gas

DEVELOPMENTS IN PETROLEUM SCIENCE 52

GEOLOGY AND GEOCHEMISTRY OF OIL AND GAS

G.V. CHILINGAR, L.A. BURYAKOVSKY, N.A. EREMENKO
& M.V. GORFUNKEL



ELSEVIER

Amsterdam – Boston – Heidelberg – London – New York – Oxford
Paris – San Diego – San Francisco – Singapore – Sydney – Tokyo

ELSEVIER B.V.
Radarweg 29
P.O. Box 211, 1000 AE
Amsterdam, The Netherlands

ELSEVIER Inc.
525 B Street, Suite 1900
San Diego, CA 92101-4495
USA

ELSEVIER Ltd
The Boulevard, Langford Lane
Kidlington, Oxford OX5 1GB
UK

ELSEVIER Ltd
84 Theobalds Road
London WC1X 8RR
UK

© 2005 Elsevier B.V. All rights reserved.

This work is protected under copyright by Elsevier B.V., and the following terms and conditions apply to its use:

Photocopying

Single photocopies of single chapters may be made for personal use as allowed by national copyright laws. Permission of the Publisher and payment of a fee is required for all other photocopying, including multiple or systematic copying, copying for advertising or promotional purposes, resale, and all forms of document delivery. Special rates are available for educational institutions that wish to make photocopies for non-profit educational classroom use.

Permissions may be sought directly from Elsevier's Rights Department in Oxford, UK: phone (+44) 1865 843830, fax (+44) 1865 853333, e-mail: permissions@elsevier.com. Requests may also be completed on-line via the Elsevier homepage (<http://www.elsevier.com/locate/permissions>).

In the USA, users may clear permissions and make payments through the Copyright Clearance Center, Inc., 222 Rosewood Drive, Danvers, MA 01923, USA; phone: (+1) (978) 7508400, fax: (+1) (978) 7504744, and in the UK through the Copyright Licensing Agency Rapid Clearance Service (CLARCS), 90 Tottenham Court Road, London W1P 0LP, UK; phone: (+44) 20 7631 5555; fax: (+44) 20 7631 5500. Other countries may have a local reprographic rights agency for payments.

Derivative Works

Tables of contents may be reproduced for internal circulation, but permission of the Publisher is required for external resale or distribution of such material. Permission of the Publisher is required for all other derivative works, including compilations and translations.

Electronic Storage or Usage

Permission of the Publisher is required to store or use electronically any material contained in this work, including any chapter or part of a chapter.

Except as outlined above, no part of this work may be reproduced, stored in a retrieval system or transmitted in any form or by any means, electronic, mechanical, photocopying, recording or otherwise, without prior written permission of the Publisher.

Address permissions requests to: Elsevier's Rights Department, at the fax and e-mail addresses noted above.

Notice

No responsibility is assumed by the Publisher for any injury and/or damage to persons or property as a matter of products liability, negligence or otherwise, or from any use or operation of any methods, products, instructions or ideas contained in the material herein. Because of rapid advances in the medical sciences, in particular, independent verification of diagnoses and drug dosages should be made.

First edition 2005

ISBN-13: 978-0-444-52053-1
ISBN-10: 0 444 52053 8
ISSN: 0376-7361 (Series)

© The paper used in this publication meets the requirements of ANSI/NISO Z39.48-1992 (Permanence of Paper).
Printed in The Netherlands.

DEDICATION

This Book is dedicated to

His Highness Sheikh Hamad Bin Khalifa Al Thani
The Emir of the State of Qatar

And

Her Highness Sheikha Mozah Bint Nasser Al Missned

For their global vision and dedication to democratic reform,
education, and
valiant efforts in promoting peace in the region

This page intentionally left blank

FOREWORD

The geology and geochemistry of petroleum are becoming ever more important as the demand for fossil fuels increases worldwide. We must find new hydrocarbon reserves that are hidden in almost inaccessible areas. Our knowledge of petroleum geology and geochemistry is the best intellectual tool that we have for the never-ending search for rich new deposits of hydrocarbons. The geology of the rocks under deep oceans and on continental shelves has become much more important as advances in technology permit drilling in these areas. Developments in petroleum geology and geochemistry, and advances in seismic and well-logging measurements, provide a better understanding of the evolution of subsurface sedimentary deposits and the migration, entrapment, and production of hydrocarbons.

This book touches upon the great strides that are being made through electronic innovations in instrumental measurements of geologic and geochemical systems. The structure of the book is actually a balance of four topical sections. The fundamental aspects of petroleum geology, geochemistry, and accumulation, evaluation, and production of subsurface fluids are discussed in the first three sections followed by the fourth section on mathematical modeling of geologic systems.

Chapters 1–3 introduce a systematic approach to understanding sedimentary rocks and their role in the evolution and containment of subsurface fluids. This is discussed in relation to the physical conditions of hydrocarbon reserves (e.g., at very high temperatures and pressures).

Chapters 4–6 discuss the physical and chemical properties of subsurface waters, crude oils and natural gases. The physical and chemical properties are especially important to production engineering and mathematical simulation because they impact the relative motions of fluids as saturation changes during production: (1) wettability of rocks affects production characteristics and ultimate recovery; (2) relative permeability affects fluid movement to the production wells; (3) density differences between immiscible fluids affect gravity drainage from one part of the reservoir to another as the reservoir fluids are depleted; (4) viscosity of fluids affects the relative mobility of each fluid; and (5) fluid chemistry affects the absorption, ultimate recovery and monetary value of the produced hydrocarbons.

Chapters 7–10 discuss the formation and accumulation of crude oils and natural gases: (1) changes in the chemical composition of hydrocarbons that originate from the debris of living plants to form crude oils; (2) the origins of hydrocarbons in different areas of a single reservoir; also, the conditions which determine the distribution of water, oil, and gas in the reservoir; (3) migration of subsurface fluids until they eventually accumulate in isolated geologic traps; and (4) a discussion of the oil traps as a function of sedimentary geology.

Chapter 11 explains the analytical and statistical approaches to modern mathematical modeling of both static and dynamic geologic systems. Modeling of static systems (i.e., simulation of the structure and composition of geologic systems) is done regardless of time to develop a basis for geologic exploration and hydrocarbon reserve estimation, whereas dynamic models capture any changes taking place with respect to time for use in studying production and field development.

This book is recommended to the geologists, geochemists, petroleum engineers, and graduate university students studying petroleum geology, engineering, and geochemistry.

E.C. Donaldson
Managing Editor of Journal of
Petroleum Science and Engineering
Wynnewood, Oklahoma

PREFACE

The progress in the oil and gas industry is related closely to the acceleration of discovery rates, exploration, development, and production of hydrocarbon resources. Exploration, development, and production of hydrocarbon resources must be based on reliable information, which helps to predict subsurface conditions and properties of oil- and gas-bearing formations.

Main oil and gas reserves are found in sedimentary basins composed of terrigenous (siliciclastic), carbonate, and, sometimes, volcanic or volcanoclastic rocks. Preservation of high reservoir pressure and good properties of reservoir rocks and seals (caprocks) in these basins depends greatly on their origin and further evolution. The process of sedimentation, and the following processes of diagenesis (i.e., physical, chemical and biochemical processes, which occur in the sediments after sedimentation and through lithification at near-surface temperature and pressure) and catagenesis (or epigenesis) (i.e., physical and chemical processes, which occur in the sedimentary rocks at high temperatures and pressures after lithification and up to metamorphism), cause alterations, which may enable one to predict oil and gas potential.

Considering an interest demonstrated by petroleum geologists and reservoir engineers, this book discusses the major theoretical and practical problems of petroleum geology and geochemistry as they are viewed at the end of the 20th century and the beginning of the 21st century. The treatment of the material is non-uniform in the sense that the accepted scientific concepts are treated cursorily, just to maintain the completeness and continuity of the story, whereas the disputable and innovative issues are handled in more detail. The discussion is conducted from a position of the science of petroleum geology, geochemistry, and other related disciplines. For instance, in describing oil-bearing sequences, the main brunt is on depositional environments and such features as reservoir and fluid-sealing properties. A considerable attention is devoted to the transformations within the rock–water–organic matter system of the Earth's crust with changes in the subsurface temperature and pressure. New reservoir and accumulation types are identified and their exploration/development features are defined.

A variety of common reservoir engineering problems can be solved during field development and production by the integration of geological, geochemical, and engineering studies. For example, such studies can identify reservoir compartmentalization, allocate commingled production, identify completion problems (such as tubing leaks or poor casing cementing jobs), predict fluid properties (viscosity, density) prior to production tests, characterize induced fracture geometry, monitor the waterflood process and water encroachment, or explain the causes of produced sludge.

Discussions in this book are based on the systems approach to the specific geologic systems. Along with this approach, mathematical modeling of the static and dynamic geologic systems is described as well. The use of mathematical methods and computer techniques increases the scope of problems that can be solved on the basis of integrated geological, geophysical, geochemical and engineering information. Mathematical methods using computer processing of the current information accelerate the process of regional and local prediction of oil and gas potential that, in general, increases the economical and geologic efficiency of exploration, development, and production of oil and gas.

George V. Chilingar, Leonid A. Buryakovsky

NOMENCLATURE

A_{da}	diffusion–adsorption factor
A_t	absolute geological age
B	“benzine” (gasoline) content
B_{el}	bulk volume elasticity
B_f	fracture spacing
C	classification
C_{carb}	carbonate cement content
C_{cl}	clay cement content
D	depth
d	water density at 3.98°C
d	diameter
d_w	wellbore diameter
d_{act}	actual wellbore diameter
d_{nom}	nominal wellbore diameter
d_{ch}	pore-channel diameter
$d_{p,ave}$	average pore diameter
$d_{p,Me}$	median pore diameter
E	expectancy
F	formation resistivity factor
$F_{p,t}$	formation resistivity factor at reservoir conditions
F'	resistivity index
$F'_{p,t}$	resistivity index at reservoir conditions
G	geothermal gradient
G_o	oil pressure gradient in reservoir
G_w	initial water pressure gradient in seal
ΔG	Gibbs free-energy difference
H	entropy of information
H_{max}	maximum entropy
H_r	relative entropy
H_0	zero hypothesis
h	thickness
h_{eff}	effective (net) thickness
h_{sh}	shale thickness
Δh_{seal}	seal thickness
Δh	accumulation column
I	quantity of information
ΔI_γ	relative GR factor

ΔI_{ng}	relative NGR factor
K	filtration coefficient
K_a	pressure-abnormality factor
k	permeability
k_{\parallel}	permeability parallel to bedding
k_{\perp}	permeability perpendicular to bedding
k_i	modeling coefficient of sediment compaction
L	ligroin content
L	length
L_c	length of capillaries
M	mathematical expectancy
M	molecular mass
m	mass
m	number of parameters in the data matrix
m	cementation exponent
N	number of measurements, tests or observations
n	number of objects in the data matrix
n	saturation exponent
O	object
P	parameter
P_{acc}	accumulation's total potential energy
$P_{breakthrough}$	breakthrough potential
P_{pw}	maximum potential of pore water in seal
$P_{w.l, \text{ layer}}$	water potential of the lower layer
$P_{w.u, \text{ layer}}$	water potential of the upper layer
P_{wr}	water potential in reservoir
p_i	probability
P_c	capillary pressure
P	pressure
p_e	external pressure, total overburden pressure
p_f	formation pressure
p_i	internal pressure, pore-fluid pressure
p_{eff}	effective (grain-to-grain) pressure
p_{lit}	lithostatic (overburden) pressure
p_p	pore pressure
p_r	reservoir pressure
p_{norm}	normalized pressure
Δp	pressure differential
Q_{100}	cation-exchange capacity per 100 g of rock
q	volumetric flow rate
q_{liq}	liquid production rate
q_{oil}	oil production rate
R	content of resins and asphaltenes
R_d	rate of sedimentation

$R(z)$	vertical water density change
R	electric resistivity
R_a	apparent resistivity
$R_a(\text{AO})$	apparent resistivity from lateral sonde of AO size
R_{cr}	cut-off (critical) resistivity of oil-saturated reservoir
$R_{\text{g,r}}$	resistivity of gas-saturated reservoir
R_{oil}	oil resistivity
$R_{\text{o,r}}$	resistivity of oil-saturated reservoir
R_{sh}	shale resistivity
R_t	true resistivity of rock
$R_{t,\text{min}}$	minimum true resistivity
R_w	water resistivity
R_o	resistivity of water-saturated reservoir
R_m	drilling-mud resistivity
R_{mf}	mud-filtrate resistivity
R_{IL}	resistivity from induction log
r	correlation coefficient
r	radius
r_c	radius of capillaries
S_o	oil saturation
$S_{o/g}$	oil/gas saturation
$S_{o,r}$	residual oil saturation
S_w	water saturation
$S_{w,r}$	residual water saturation
S_{carb}	homogeneity of carbonates
S_{sort}	sorting factor
S_{sh}	sorting of shales
S_{ss}	sorting of sandstones
s_b	specific surface area of pore space per unit of bulk volume
s_g	specific surface area of pore space per unit of grain volume
s_p	specific surface area of pore space per unit of pore volume
s_{hf}	shape factor for pores
SG	specific gravity
T	temperature
ΔT	interval transit time
t	time
t_α	probability index at confidence level α
U	relative change in volume of sediments
ΔU_{SP}	relative SP factor
V	volume
V_c	volume of capillaries
V_{AHFP}	rate of AHFP formation
V_{elast}	rate of creation of elastic stress
V_{relax}	rate of stress relaxation

V_s	seismic velocity
v	specific volume
v_λ	variation of anisotropy
v_R	variation of resistivity
z_o	altitude of comparison surface with equal normalized pressure
α	level of significance (confidence level)
α_{SP}	SP reduction factor
β	modulus of elasticity
β_c	irreversible compaction factor (compressibility factor)
γ	density
γ_o	oil density
γ_w	water density
η_{cl}	relative clay content in rock
η_p	pore-pressure gradient
η_{sh}	pore-pressure gradient in shales
η_r	formation-pressure gradient in reservoir rocks
λ	anisotropy coefficient
μ	dynamic viscosity
ν	kinematic viscosity
σ	stress; tension
σ	standard deviation, or mean square error
σ_R	standard deviation of resistivity
σ_r	standard deviation of correlation coefficient
τ	electrical tortuosity of pore channels
τ_w	thickness of pore-water film
ϕ	porosity
ϕ'	“residual” porosity
ϕ_{eff}	effective porosity
ϕ_{sh}	shale porosity
χ_{sh}	relative content of argillaceous (shale) beds
ω	frequency or probability
$\Sigma\omega$	cumulative frequency or cumulative probability
Σ	macroscopic cross-section of thermal neutron capture (absorption)

ABBREVIATIONS

AHFP	abnormally high formation pressure
ALFP	abnormally low formation pressure
bbbl	barrels
BCF	billion cubic feet
BCM	billion cubic meters
BPD/bpd	barrels per day
CFD/cfd	cubic feet per day
CMD/cmd	cubic meters per day
FSU	Former Soviet Union
GKZ	State Committee on Reserves (in FSU and RF)
GOC	gas-oil contact
GOR	gas/oil ratio
GWC	gas-water contact
HC	hydrocarbons
MBPD/Mbpd	thousand barrels per day
MCFD/Mcfd	thousand cubic feet per day
MCMD/Mcmd	thousand cubic meters per day
MD	measured depth
MMBPD/MMbpd	million barrels per day
MMCFD/MMcfd	million cubic feet per day
MMCMD/MMcmd	million cubic meters per day
MMT	million tons
MSE	mean square error
MTD	thousand tons per day
OWC	oil-water contact
PTD	proposed total depth
RF	Russian Federation
SEM	scanning electron microscope
TCF	trillion cubic feet
TD	tons per day
TD	total depth
TOC	total organic carbon
TPD/tpd	tons per day
TVD	true vertical depth

This page intentionally left blank

CONTENTS

Dedication	v
Foreword	vii
Preface	ix
Nomenclature	xi
Abbreviations	xv
<i>Chapter 1</i> SYSTEMS APPROACH IN SCIENCE	1
Natural systems and their classification	1
Rocks, water, organic matter, and gases as a specific natural system	7
Systems approach in petroleum geology	8
<i>Chapter 2</i> OIL AND GAS-BEARING ROCKS	19
Composition of oil- and gas-bearing rocks	19
Reservoir rocks	20
Porosity	21
Permeability	22
Caprocks	29
Oil and gas reservoirs	35
<i>Chapter 3</i> TEMPERATURE AND PRESSURE IN THE SUBSURFACE	39
Deformation of rocks in depth	39
Porosity and permeability versus depth of burial	39
Temperature	42
Paleotemperature	49
Abnormally-high formation pressure	51
Well-logging data	51
Seismic data	52
Drilling data	53
Effect of pressure and temperature	58
Effect of formation water chemistry	62
Secondary montmorillonite	64
Origin of abnormal formation pressures	64
<i>Chapter 4</i> WATER	71
Physical and chemical properties of waters	71
Classifications of oilfield waters	75
Water drive	79
Water drive systems	80
<i>Chapter 5</i> CRUDE OILS	87
Composition of crude oils	87
Classification of crude oils	89
<i>Chapter 6</i> NATURAL GASES AND CONDENSATES	101
Composition of natural gases	101

Isotope composition of natural gases	103
Carbon	103
Hydrogen	103
Sulfur	104
Nitrogen	104
Inert gases	105
Physical properties of natural gases	106
Gas density	106
Combustion heating value.	107
Compressibility of natural gases.	107
Deviation of pressure at bottom of gas column.	108
Gas viscosity	109
Hydrate formation	109
Solubility of gases in water	110
Solubility of hydrocarbon gases in crude oils	111
Phase transformation and condensates	112
<i>Chapter 7</i> DISPERSED ORGANIC MATTER.	117
Organic matter insoluble in organic solvents: Kerogen.	117
Insoluble Portion of Organic Matter	118
Organic matter soluble in organic solvents	125
Combined studies of soluble and insoluble portions of organic matter.	129
<i>Chapter 8</i> ORIGIN OF OIL AND NATURAL GAS	135
Initial organic matter and its transformation.	135
Stagewise nature and cyclic transformation of organic matter.	138
Role of energy in the oil generation process	141
<i>Chapter 9</i> FORMATION OF HYDROCARBON ACCUMULATIONS.	147
Sedimentary basins.	147
Hydrocarbon expulsion (“Primary Migration”), heterogeneity of the medium, dissolution in water and gas, diffusion	151
Overburden Pressure.	153
Pore Pressure	153
Rock Compaction	154
Temperature	154
Geochemical Non-Uniformity	154
Dissolution in Compressed Gases (See Retrograde Dissolution in Chapter 6).	157
Diffusion	157
Primary accumulation and free phase migration (“Secondary Migration”).	158
Time of formation of hydrocarbon accumulations.	169
Paleogeologic Method.	169
Mineralogic Technique	169
Helium–Argon Technique	170
Determination Based on the Composition of Oil Fractions with Boiling Point Below 200°C	170
Volumetric Technique	170
Saturation Pressure Technique.	171
<i>Chapter 10</i> CLASSIFICATIONS OF OIL AND GAS ACCUMULATIONS.	173
Classification of types of oil and gas accumulations and traps. Reserves, fluid quality, and production rates.	173
Classification of hydrocarbon accumulations based on the phase relationships	175
Gas accumulations	175

Oil accumulations	177
Classification of oil and gas reservoirs based on drive mechanism	183
Solution gas drive	184
Gas-cap drive	187
Water drive	188
Gravity drainage	191
Combination-drive reservoirs	191
Open combination-drive reservoirs	191
Closed combination-drive reservoirs	193
Classification of hydrocarbon accumulations based on the type of traps	194
Vertical zonation of hydrocarbon accumulations	198
<i>Chapter 11</i> MATHEMATICAL MODELING IN PETROLEUM GEOLOGY	205
Principles of mathematical modeling of geologic systems	205
Models of static geologic systems	209
Analytical approach	210
Entropy of geologic systems	210
Anisotropy of sedimentary rocks	215
Petrophysical relationships	217
Statistical approach	221
One-dimensional models	221
Rock properties	221
Crude oil properties	225
Two-dimensional models	227
Reservoir rocks	227
Crude oil	230
Natural gas	236
Formation water	237
Multidimensional models	240
Reservoir rocks	240
Crude oil	241
Models of dynamic geologic systems	249
Analytical approach	250
Statistical approach	251
Combination of analytical and statistical approaches	256
Sediment compaction	256
Simulation of rock properties	257
Prediction of rock properties	265
Prediction of hydrocarbon reserves	265
Evolution of pore-fluid (formation) pressure	270
Simulation of oil/water mobility	271
Algorithm of accelerated exploration for hydrocarbon accumulations	273
Concluding remarks	273
Appendix A (Wettability and Capillarity)	275
Appendix B (Permeability)	289
Appendix C (Glossary)	295
References and Bibliography	345
Index	361

This page intentionally left blank

Chapter 1

SYSTEMS APPROACH IN SCIENCE

1.1. NATURAL SYSTEMS AND THEIR CLASSIFICATION

Despite political, economical, and military crises, oil and natural gas usage in the world is growing. Ecological problems are becoming more serious. Any concerns about the future cannot undermine humankind's drive to the technical progress provided by using oil and natural gas. The environmentalists are preventing the construction of nuclear power generating plants, and the alternative sources of energy, probably will not satisfy more than 15–20% of the world energy demand. Thus, the demand for oil and natural gas will grow.

Usually such a statement is accompanied by another statement on the limited amount of these mineral resources. This should be clarified. From the viewpoint of inorganic origin of hydrocarbons, the process of hydrocarbon accumulation is continuing. A possible resource replacement due to inorganic synthesis, however, has not been discussed here, because most scientists reject the possibility of hydrocarbon accumulation via this process. Some proponents of the organic theory (Weber et al., 1966; Miller, 1991; Hunt, 1979) believe that hydrocarbons could have formed in Pleistocene and Quaternary sediments. Hunt (1979) stated that inasmuch as about 9% of hydrocarbons entered the sediments directly from the living organisms; they may have originated hydrocarbon accumulations in the Quaternary. Such amounts of resources cannot be disregarded.

In addition to the irreplaceability, or rather a very low replaceability, of the hydrocarbon resources it is also very difficult to discover new ones. Most of the “easy” accumulations (shallower than 4000 m and associated with the most common anticlinal traps in mature basins) have been already discovered. Discovery of accumulations associated with non-conventional traps and those present at great depths and in the offshore basins required non-conventional exploration techniques. This resulted in an accelerated development of geophysical (mainly seismic), geochemical and, even, space exploration techniques.

Technology of exploratory drilling was simultaneously progressing: (1) the drilling penetration rate increased, (2) core and fluid sampling techniques became available without interrupting the drilling process, (3) logging and measuring-while-drilling methods were developed, and (4) horizontal drilling in the productive reservoirs became a reality. The time has come to reconsider the old theoretical concepts in view of the progress achieved in allied scientific disciplines (physics, chemistry, geochemistry, geotectonics, lithology, geomathematics, etc.). The basis for this reconsideration is the systems approach.

Intuitive systems approach was introduced in natural sciences by two prominent biologists and philosophers: Jean Baptiste Lamarck (1744–1829), in the book entitled *Zoological Philosophy* (1809), and Charles Darwin (1809–1882), in the book

entitled *The Origin of Species by Means of Natural Selection, or the Preservation of Favored Races in the Struggle for Life* (1859). Intuitive approach, however, is subjective. Objective description of this phenomena could only be achieved through the development of scientific methodologies.

The foundation of objective approach was developed by English politician, philosopher, and essayist Francis Bacon (1561–1626), and French mathematician, scientist, and philosopher René Descartes (1596–1650). The former, in his most important philosophical work entitled *Instauratio Magna* (1620), redefined the task of natural science, seeing it as a means of empirical discovery and a method of increasing human power over nature, and maintained that only a sound method results in a true knowledge. The latter, in his books entitled *Meditation on First Philosophy* (1641), *Discourse on Method* (1637), and *Principles of Philosophy* (1644), ignored accepted scholastic philosophy and stated that the person should doubt all sense experiences and that only the axioms or postulates that are beyond any doubt may be used as a basis for scientific logical constructions. Both concepts are still unshakable and were used for the development of a systems (system-structural) approach in science.

As Dmitriyevskiy correctly noted, “systemity is a general pattern in the structure of material universe” (1993, p. 2). At the same time, even the perfect study methodology does not guarantee the true knowledge. A lot depends on (1) the reliability of empirical base, (2) the availability of sufficiently differentiated and in-depth theoretical apparatus, (3) the scientist’s qualifications, and (4) materialistically understood factors, such as intuition and creative imagination (Lopatin, 1983, p. 22).

There are numerous definitions of a “system”. All of them, however, are vague. For example, according to one of the definitions: “The system is a set of interacting elements” (Afanasyev, 1973, p. 39), or a clearer definition: “The system is a complex of interconnected elements that form some integrity” (Gvishiani, 1980). Vagueness here is hidden in “a complex of interconnected elements” and in “some integrity”. The following questions arise: Which elements and how are they interconnected? Are the elements uniform, variable in size, or heterogeneous? What type of connections: physical or logical? What kind of integrity: logical, mechanical, energetic, or their absence?

We understand that it is easier to criticize than to create. Thus, let us develop a definition of “geologic system” best suited for studying theoretical problems of petroleum geology.

It may be stated that the geologic system is an aggregate of interrelated natural elements of lithosphere that form an integral whole, with specific properties changing with time. This definition is similar to the definition given by Buryakovskiy et al. (1990): “Interrelated elements are involved in the naturally occurring processes eventually resulting in profound changes in the component elements and in substantial changes of the whole system, i.e., practically, the appearance of a new system”.

Many authors provide only the most general methodological recommendations for using the system-structural analysis when studying systems. This may be accepted if structural analysis is broadly understood as a process of explaining the interaction

patterns not only between the system's components (internal patterns), but also between the systems (external patterns). Still, this does not provide a practical way of applying stated methodological recommendations to geologic systems, in particular to the development of geologic classifications (hierarchical or genetic). At the outset of development of any scientific branch, there must be a certain classification (**C**). Cognition of the observed natural objects, turning them into subjects of study is the first and unavoidable step in the process of classification (**C**).

“**C** facilitates the transition of science or a technical branch from the stage of empirical accumulation of knowledge to the level of theoretical synthesis (i.e., systems approach). Such an approach is only possible if there is a theoretical comprehension of multiplicity of facts. The practical need in **C** is an incentive for the development of theoretical aspects of science and technology. The development of **C** is a quantum leap in the evolution of knowledge. Not only does **C**, when it is based on strict scientific basis, represent a broad reflection of the state of science (technology), but **C** also enables scientists to generate substantiated forecasts regarding not yet known facts or patterns. One such example is the forecast of properties for yet unknown chemical elements using Mendeleev's system” (Yakushin, 1975).

There are two ways to develop **C** — deductive and inductive.

The first approach consists of setting initial general concepts in the process of subdivision and then identifying subordinate notions within the subdivisions. The unity of subdivision principles and the stability of **C** are ensured by the method of its development. The second approach is based on perception of individual subjects and their aggregates, which are joined into classes. Using the second approach, it is more difficult to ensure logical unity and stability of **C** than it is with the first approach. Deduction is preferred for systematizing the branches of knowledge, whereas induction is more convenient for processing actual data. These two approaches are reflections of the two ways of exploration in natural sciences — analysis and synthesis. “It is important to emphasize, however, that, methodologically, sequence of actions is more or less stable: first, analysis and then (based on it), synthesis” (Kedrov, 1980).

Earth sciences in general and petroleum geology in particular are substantially lagging behind other natural sciences dealing with synthesis as a way of “overcoming” analysis. Let us briefly review the causes of this lagging.

Development of **C**, following the formal logic, requires application of rules of subdividing volume of a concept. These rules are as follows (after Kosygin, 1978):

- (1) Classified objects must be defined, rigidly or even loosely. The reasons for this are (a) each object may be distinguished from any other object and (b) similarities between the objects could be identified.
- (2) Allocating the objects into classes, subclasses, etc., must be conducted using such parameters that can be uniquely identified.
- (3) All objects of a divisible aggregate must participate in **C**.
- (4) Each object of a divisible aggregate must fit into one (and only one) class, subclass, etc.
- (5) In case of a subsequent subdivision of a class, objects in that class must be redistributed among no less than two subclasses.

Thus, the rules of formal logic demand a deductive approach to development of **C**. In geological sciences, **C** usually developed using an inductive approach. The total of all objects within a “species” creates a new “genus”,¹ with all properties and phenomena pertinent to this “genus”. In the process, some “species” may disappear and some previously non-existing “species”, appear. Some “species” (e.g., certain secondary minerals) may be selected that may exist, as objects, only on a level of a “genus” concept.

Kosygin (1978) noted that development of **C** comprises the following steps:

- (1) Identification of some aggregate of objects (object domain) that is subject to the taxonomic analysis.
- (2) Identification of parameters of objects.
- (3) Establishing the distribution of parameters among the objects.
- (4) Grouping the objects into taxons according to this distribution.
- (5) Determination of subordination of taxons (within the hierarchical **C**).

In the above process, the following formal conditions are implicit or explicit:

- (1) The taxons must be discrete, i.e., any object may belong only to one single-rank taxon.
- (2) Parameters of objects may be represented as discrete parameters.
- (3) Possibility (in principle) to arrive at an apodictic (categorical) and reliable opinion about a parameter (**P**) belonging to an object (**O**).
- (4) Possibility (in principle) to arrive at a similar opinion about correspondence of the parameter **P** in the object **O**₁ to the same parameter **P** in the object **O**₂.

If all five steps in developing **C** and four conditions above were fulfilled when classifying natural objects, there would have been no problems with the classification. In reality, not a single one of the stated four conditions is fulfilled. Moreover, when developing a **C**, we are forced to neglect some formal rules of subdividing the volume of concepts. The rule of consistency as a basis for subdivision is often not applicable. The requirement for consistent and commensurate subdivision (for classes not to overlap) may often be satisfied only by stretching. Striving to comply with the discrete nature of classes leads to a progressive taxon fragmentation, with the taxons having overlapping parameters. The requirement for classes not to overlap is disrupted by hybrids. No formal rules can account for the common (and apparently unavoidable) subdivision of rocks into sedimentary, volcanic, and metamorphic. The parameters that are believed to have been observed, in reality are often inferred by analogy. That is why, opinions that these parameters belong to a given object have a probabilistic nature. “The actual or potential polymorphism of the parameters results in our characterization of taxons not by the presence or absence of a parameter, but by the frequency of its occurrence” (Kosygin 1978).

Thus, there is a disagreement between the way of developing **C** as recommended by formal logic (deductive approach) and the way it is done in geologic sciences (inductive approach). Any attempt to use formal logic for the evaluation of inductively

¹Herein after the words “species”, “genus”, and “class” are used only in the narrow sense of subordinated taxons.

created **C** must yield a negative result. The writers failed to find any publication that contained rules (or just recommendations) for the inductive development of **C**. It appears that in order to overcome the transition step from analysis to synthesis one needs to develop corresponding branches in formal logic.

One reason that makes the application of formal logic in geology so difficult is the nature (properties) of studied objects. Geology studies objectively existing things (bodies). These bodies are reflected in the subject studied only to some extent of reliability, which is sometimes quite low. Formal logic, on the other hand, deals with abstract concepts (products of thought) that are clearly delineated by the corresponding terminology and definitions.

Let us consider a “set”, one of the founding concepts in formal logic. Any **C** begins with the selection and description of a set. To classify, the set must be selected and somehow delimited. Within a whole set, mathematical logic considers some population of objects that have at least one common essential parameter. Nobody would try to combine into a single set items such as an oil accumulation, a solar eclipse, a geologic structure, and time. Such a “set” would be incorrect from the viewpoint of formal logic. At the same time, for some reason, it is believed as quite feasible to consider the following as a single set: oil (or gas) accumulation, trap, field, region, prospect, area, basin, province, and tectonic structure (starting with the region, prefixed with a word “petroleum”). Despite a significant mess with definitions in petroleum geology and absence of a clear-cut terminology, it is still possible to conclude that the above “set” includes:

- (a) substance (accumulation), which has quantitative and qualitative parameters;
- (b) surface (area, territory, etc.), which can be measured, e.g., in square meters;
- (c) geologic structure, i.e., spatial configuration of the Earth’s layers (here, even volume does not reflect the essence); and
- (d) time (for the cases when a basin or a province is considered in the process of evolution).

It is obvious that a **C** (especially a hierarchical one) developed for such a “set” is an absurdity. Nevertheless, the **C**’s developed for such a “set” or portion thereof is accepted by petroleum geologists. The very definition of the concept of the “set” in formal logic is an “aggregate of objects”, which implies the discrete nature of the “set”. In geology, on the other hand, what is classified is “continuity”, a unity of interconnected processes or their outcomes. They are just conditionally separated for the purpose of analysis. Also, when one follows the steps of the geologic hierarchy, a qualitative quantum leap occurs, as new properties appear and old ones disappear. In the above “set”, genetic associations may be established among many of its constituents. We do mean associations, not transitions (i.e., changes in the properties of one object depend on the status and properties of some other object). Thus, we can observe numerous attempts to develop genetic **C**’s, sometimes natural **C**’s, at the time when no methodology exists in the formal logic as to how it should be done.

The concept of a “set”, as defined in formal logic, may be used only quite conditionally in geologic sciences. As an example, let us discuss the “minerals” set. Minerals are an open population, characterized by complex combinations and numerous patterns in their association and neof ormations that change with time in the

Earth's crust. For this set ("minerals") even its very volume is difficult to define due to continuous evolution in nature. Some minerals combine to form a new mineral. Therefore, the total volume of the set decreases. In some other cases, a mineral may decompose into several minerals, and the volume of the set would increase. Upon transformation, some minerals can acquire new properties (or transfer into other sets located at different rungs of the hierarchical ladder). For instance, either chemical elements (a rung down) or a rock may form (a rung up).

A set of bituminous minerals (beginning with antraxolites at the one end and ending with oil and gas, at the other end) may be considered as an "open population" in petroleum geology. In general, "open population" is a population (or set) that can be expanded or reduced to some extent. It is distinguished from the "open system" the main property of which is the exchange of the matter, energy, and information with environment.

It is very difficult to select a significant parameter that could be used for a classification of such "open population" in compliance with the laws of formal logic. The reasons for that are numerous: (1) complex interrelations; (2) different genesis; (3) formation of different minerals (such as oil and gas) in the same environment; conversely, one mineral (such as gas) can form in totally different environments; (4) complex alterations and transformations when natural temperature and pressure change. Even if, in order to create an accumulation type classification "by the composition", one narrows down the above "open population" to just three elements (oil, gas, and condensate), the development of a natural classification will be very difficult. There is a continuous series of objects present; there are endless numbers of natural kinds and transition forms when habitat changes (including technological changes, such as production). All these circumstances result in overlapping classes and violations of the rules of formal logic of subdividing the whole concept.

Genetic parameters in geology and in particular, in petroleum geology, may play a significant role. But how would one take them into account? A recommendation of formal logic to define the particular through the general (or, as it is sometimes used in natural sciences, to define species through the genus) is of little use in this situation.

If there is a natural hierarchical classification constructed in compliance with the rules of subdividing the whole concept, then each species identified within a genus (subset within a set) preserves the significant parameters of the genus. Conversely, each species included in the genus preserves its significant species features. What actually occurs is a formal addition or division of objects. This principle intrinsic to the concept of naïve materialism of ancient Greeks was preserved in formal logic from the Aristotle's times.

Everything is much more complicated in the hierarchy of geologic bodies. There, the situation is tampered by genetic processes evolving under their own laws and resulting in profound qualitative changes. Elements composing minerals (or other chemical compounds), considerably change their properties. For instance, is there any similarity in properties of gaseous oxygen and hydrogen with the same elements forming a solid mineral or water? From the viewpoint of formal logic it would be expected that simple summation of the lower rank objects will result in higher rank

objects. This does not happen, however. Let us consider constituents (minerals) of granite. Regardless of the duration of their joint occurrence, the granite as a rock will not form until the occurrence of certain genetic processes that will combine these minerals into a rock. To transform these components into granite, high temperature and pressure are needed. Moreover, the newly formed rock may be different: not a granite but a gneiss, because some constituents of granite may have been generated in the process of its formation.

Thus, one may conclude that classification *C* in geology and particularly, in petroleum geology, covers qualitatively different sets. These sets are combined not by the unity of formally chosen parameters but by transformation (genetic) processes characterized by quantum leaps. Formal logic so far does not have the appropriate techniques of developing such genetic *C*'s. Under these circumstances, to develop geologic hierarchical *C*'s one can try the systems approach.

1.2. ROCKS, WATER, ORGANIC MATTER AND GASES AS A SPECIFIC NATURAL SYSTEM

The systems approach is natural and useful when dealing with geologic domain. A system should not be considered as a certain aggregate of constituent (composite) elements. A system as an entity is always in a state of perpetual development, with changes in the interrelations and mutual transitions among the system's elements, and interactions with the outside environment. Such changes are implemented through various processes, which are, commonly, physicochemical. The important characteristic of a natural system is its energetic state. The energetic state is the most significant parameter of a system. It appears that a general approach to the problem must consider the energetic state of the system as a whole, and not of its individual elements or kinds of energy. According to Komarov (1984, p. 163), the geoid's source of evolution is a contradictory unity of its substratum shells, including the core. All systems identified in the Earth's crust should be recognized as open systems, at least from the energy viewpoint. The total energy (*E*) of open geologic systems is the sum of the potential energy (*P*) (including elastic and surface energies), kinetic energy (*K*) and free (chemical) energy (*F*). This total energy (*E*) in the Earth's crust is not constant:

$$E = P + K + F \neq \text{const.}$$

Between terms of this inequality there are complex transitions. There are only a few geologic systems for which even the most general trend in transition may be identified.

The first step in the systems analysis is identification or delimiting of a system's boundaries. Setting the system's boundaries is an important stage of a system-structural analysis. These boundaries define the "postulate" (Descartes, 1950), which is a basis for logical constructions. Besides, this postulate determines to a significant degree the "true" method leading to the cognition (Bacon, 1938). A sedimentary sequence (formation) or a sedimentary basin is the most commonly selected main (reference) system in petroleum geology. This is an unavoidable stage on the way of

cognition in many petroleum geology problems or in development of hierarchical systems.

It is advisable to begin the analysis with construction of a simple system that includes the simplest constituents. Subsequently, depending on the major task of investigation, many other systems or subsystems may be identified. At the first stage, however, it is recommended to identify a geologic system comprising the following elements: rocks, water, organic matter (or its transformation products), and gases. A general basis for their separation as a common system is their simultaneous and regular presence within a limited geologic space. The primary element of the system is the rock (mineral) portion. However, the other constituents are not neutral in the system's evolution. They interact with one another and with the surrounding matrix (rock), and are unequal in terms of their mass. The rocks usually constitute tens of percents of the mass and volume of the system (coal and peat are excluded). Water and water vapor fill the pores in rocks and compose a few tens of percent to infinitely small amounts in the system. Organic matter or its transformation products are usually within a few percentage points, rising sometimes up to 10% (coal, peat) or dropping to infinitely small amounts. Natural gases are mostly dissolved in the liquids of the system. Individual elements of this system and the system as a whole are exceptionally sensitive to changes in the temperature, pressure, and geochemical environment.

1.3. SYSTEMS APPROACH IN PETROLEUM GEOLOGY

The objects of study in geologic sciences are geologic bodies (systems). A concept of the geologic system covers the entire domain of specific geologic terms related to particular geologic bodies. There are various definitions of a "geologic system". For instance, "geologic system is such a system that is formed by interaction of the planet's near-surface layers; this interaction includes the effect of both the Earth and the Universe that became exterior to the planet. The geologic system includes the Earth's crust in its structure" (Kurazhkovskaya, 1970).

Within the framework of applied geology, a geologic system is a well-organized natural assembly of interconnected and interacting elements of lithosphere having common development history and comprising a single natural unit with properties that are not inherent in their individual elements (Buryakovsky and Dzharafarov, 1983).

Thus, it is possible to define specific systems depending on their natural properties (for natural bodies) or on the objective of their creation (for engineering and natural systems). As an example, let us consider compaction of deposits occurring in a complex laminated system of rocks saturated with various fluids and subjected to numerous diagenetic processes. Buryakovsky and Dzhevanshir (1987) proposed a concept of lithofluidal system, which is useful for understanding compaction processes. They stated that the lithofluidal system is a well-organized natural assembly of interacting solid, liquid and gaseous elements of lithosphere having

common development history and a distinguishing set of physical and chemical properties that manifest themselves both individually and jointly.

An engineering-natural system may be defined as a complex of spatially ordered and temporally interconnected natural and engineering elements, the emergent property of which is utilization of natural elements to satisfy needs of human society. It follows from the above that a geotechnical system may be defined as a complex of spatially ordered and temporally interconnected natural and engineering elements, the emergent property of which is the recovery of mineral resources from the sub-surface.

As opposed to the above statements, “*The Mining Encyclopedia*” (1986) provides a narrower definition: “a geologic system is a natural-engineering aggregation of interacting natural and artificial objects”. This definition does not clarify the major property of such a system.

Thus, a geologic system, as any other system, is distinguished first of all by its special defining property, which manifests itself in the system’s integrity as a material entity. The identification of the defining property of a system differs from the simple superposition of the properties of its elements (that is obtained through techniques of logical analysis and synthesis), which is a difficult problem.

A variety of viewpoints regarding the substance of the systems approach and a variety of the system definitions manifests the complexity of the real world, i.e., the diversity of various systems. System classification is methodologically important in technical and natural-science disciplines, which include earth sciences with their practical applications (see Afanasyev, 1980, pp. 48–52).

All known system classifications are in essence classifications of the systems’ properties as well as properties of the elements composing a particular system. That is the reason why the classification presented in Table 1.1 includes not the classes of systems, but the classes of major properties of systems used for their identification.

Systems are studied utilizing techniques of formal (mathematical) logic. The extent of formal and mathematical description form of a specific scientific knowledge or methodological research depends on the completeness of abstraction of real concepts. It is noteworthy that system studies within the framework of a particular scientific discipline may be conducted along two distinctive paths similar to the inductive and deductive avenues of deriving new knowledge and developing scientific theories. System of types of solutions (deductive, abductive, inductive) shown in Table 1.2 is based on the variation of well-known syllogism of Aristotle: “All men are mortal, Socrates is a man, therefore Socrates is mortal”. The nature of models depends on the complexity of the studied objects and the extent of their organization (Table 1.3). Description of system models involves the use of appropriate mathematical instruments. The most complex objects are ranked as systems and are studied within the framework of the systems approach.

Currently, three directions are known in the modern geologic sciences for the system identification: (1) natural-objective, (2) goal-oriented, and (3) system-creating (see *Systems Approach in Geology*, 1983).

Proponents of the first direction believe that geologic system exists as the objective reality within the natural geologic boundaries. The goal of a researcher is to find

TABLE 1.1

Classification of natural and technologic systems (modified after Buryakovsky et al., 1990)

Distinctive features of systems used in classification								
	System origin	System size	System complexity	Time dependence	Exchange with environment by	Type of system isolation	Type of available information	Type of system description
Classes	Natural Technological	Sub-local	Very simple	Static systems Dynamic systems	Matter Energy	Open systems Closed systems	Qualitative Quantitative	Deterministic Stochastic
		Local	Simple					
	Scientific/ engineering Technical/ economic	Super-local	Complex	Information	Totally confined systems	Combined		
		Sub-global Global Super-global	Very complex					
Subclasses	Natural science Engineering			Intermittent Continuous Cyclic Stable Self-evolving			Incomplete Complete	

TABLE 1.2

System of types and classes of solutions

Class of solution	Type of solution	Major premises		Examples	Note
		Given	To be determined		
Strict	Deductive	X, R	Y	Socrates is a man <u>All men are mortal</u> Socrates is mortal	
Strict and heuristic	Abductive	Y, R	X	Socrates is mortal <u>All men are mortal</u> Socrates is a man	To the inference: Socrates may be a dog!
Heuristic	Inductive	X, Y	R	Socrates is a man <u>Socrates is mortal</u> All men are mortal	The inference is one of possible hypotheses

Definitions of syllogism premises: X and Y = categorical (subject and predicate) premises, R = response premise (conclusion of syllogism).

TABLE 1.3

System of models

Organization of objects	Complexity of objects	
	Simple	Complex
Not organized	Initial properties	Stochastic models
Organized	Deterministic models	Systems models

these boundaries and to study 'structural and functional properties of geosystems' within them.

Proponents of the second direction agree with the substantial-structural reality of geologic bodies. At the same time, they believe that of major importance, while separating geologic system from a given objective environment, is the purpose-assigning activity of a researcher. Namely, depending on the objective of the study, different geologic systems may be selected from the same objective reality, and the study of these systems is possible by modeling them.

Proponents of the third direction consider the systems approach as a creating activity of a researcher cognizing a given geologic reality. This enables one to solve various theoretical and practical problems and develop models reflecting the real geologic systems. This development is based on setting the goal when selecting the

object of a study, engineering the systems-related object of activity and optimizing the process of activity, management, and control.

It is important that the three aforementioned directions are not antagonistic to each other, but represent the sequential stages in studying geologic systems. First, the geologic system is identified and studied as a natural geologic body. Then, mostly in the process of its engineering-technological utilization, it is analyzed and modeled in order to understand its functions as a natural-engineering system. Eventually, the system-creating approach merges the analytical and synthetic stages in studying and developing systems, and is the methodological basis for a cognitive and creative activity.

The identification of geologic systems and delineation of their boundaries, therefore, should be conducted based on the goal stated for each particular situation and each particular objective of the study. The boundaries of geologic systems may be set based on different considerations: genetic, regional, the method of engineering-technological activity, economics, etc. Hence, one of the major tenets of natural sciences, the relativity principle, manifests itself in the procedure of identifying geologic systems.

The tentativeness of the geosystem identification follows from the fact that it is an open system that exchanges matter, energy, and information with the environment. The information exchange is a determining property of not only geosystems but also of any natural and engineering-technological (i.e., natural and artificial) systems. Studies of the structure and behavior of the systems, enables one to obtain scientific knowledge needed for the engineering-technological utilization of these systems.

As mentioned above, geosystems are open systems. At the same time, closed (but not isolated) systems are widely used in theoretical and practical geologic studies. In fact, any theory serving as a model of a geologic phenomenon or process represents a tentatively closed (quasi-closed) system. Almost all laboratory experiments in geology, geochemistry, and geophysics are conducted in the framework of quasi-closed systems, where a researcher has to neglect the effect of environment. An economic mineral deposit, especially a solid one, is always considered as a closed system. When developing oil and gas accumulations, one is dealing with quasi-closed systems. This is especially true if the oil production occurs without the advance of the oil–water contact (e.g., reservoirs with depletion drive). The concept of the quasi-closed system allows one to simplify the solution of scientific problems.

An important property of any system is hierarchy of its components. As a rule, it involves only one characteristic of the classification, namely, its scale. Hierarchically subordinated components of a system usually differ not in their physical nature, but in scale. For example, the petroleum basin system may be subdivided into subsystems of oil- and gas-bearing regions, fields, and accumulations consecutively included into one another. In this subordination, each one of the subsystems preserves the general geological and physical features inherent with the system of petroleum basin.

On the other hand, a unified system (including a geologic system) can contain elements of different nature, diverse aggregate state, and distinctive physical nature. As an example, the system of petroleum basin, as well as the subsystems of oil and

gas regions, fields, and accumulations, contains such components as (1) reservoirs; (2) seals (caprocks); (3) formation fluids (oil, gas, water); (4) tectonic, stratigraphic, lithologic, and other barriers, etc. In the above short list, no attempt was made to compare the system components for their complementarity, which would be necessary in order to emphasize their physical distinctions. Obviously such system's components are also the subsystems of the original system. Such hierarchy would be substantially different from a hierarchy based on the subsystem's scale and, to some degree, its complexity. One example of such an approach to the hierarchy of a megasystem is the classification of oil and gas accumulation traps (Fig. 1.1) (Kerimov, 1985).

If geology is defined as a complex of scientific disciplines dealing with the composition, structure and evolution of the Earth's crust and the Earth as a whole, then it would be natural to subdivide the objects of geologic science disciplines into the static and dynamic ones depending on time considerations. In static, matter-structural problems, the time is set, whereas in dynamic problems, the time changes, in a discrete or continuous way, non-periodically or cyclically depending on the specific geologic process of interest.

The existence and functioning of dynamic geologic systems is controlled by various processes, which depend on diverse natural factors. The dynamic systems, which

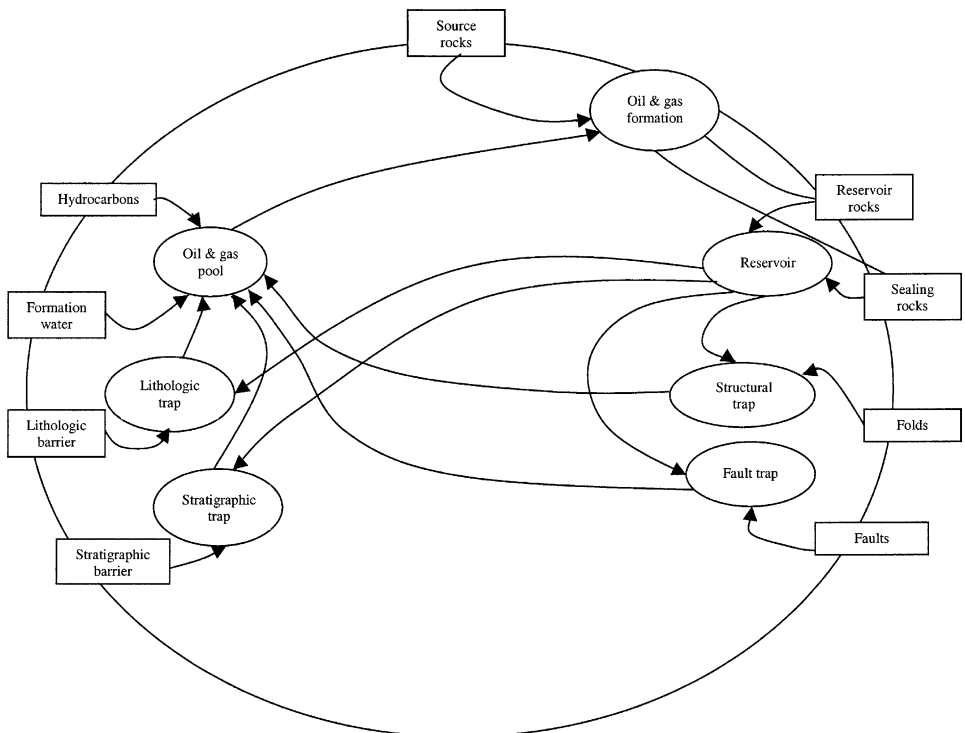

Fig. 1.1. Oil and gas area static system (modified after Kerimov, 1985).

possess relatively stable inherited structure, evolve and change with time. At a given moment in geologic time, such systems are stable integral structures in a state of dynamic equilibrium with the environment. This equilibrium is caused by a combined effect of a set of natural factors.

Forecast of the structure and behavior of dynamic systems in time is the matter of systems forecasting. A specific feature of the systems forecast in geology is the necessity and feasibility to forecast the behavior and structure of the geologic system both in time and space. On the basis of the structure of the space–time continuum of lithosphere, it is possible to identify changes in geologic system with depth and time. Thus, the geologic forecast is actually a “retrocast”, directed back in time and in depth. According to Kosygin and Solovyev (1969), the dynamic and retrospective geologic systems are actually dynamic systems with the forward and reverse time count.

The cognition of geologic systems is based on their modeling. Modeling in geology is a creation of a physical, matter-structural object reflecting major properties of the system studied in an isomorphic way. It may also be a logical-mathematical construction reflecting equally the structure and behavior of the system being studied. Modeling in geology is commonly utilized for a brief characterization of systems as well as for the forecast of their behavior and structure in time and space (Buryakovsky et al., 1982).

A specific feature of mathematical modeling of dynamic geologic systems and geologic processes is the necessity to take into account the time factor. The modeling of dynamic geologic systems uncovers the unity of such opposite methodological approaches as the systemic-structural and genetic-historical. The merger of the structural and historical approaches enables one to consider a geologic system as a natural structure, which (1) is relatively stable during a specific time period, and (2) is evolving and changing over a long interval of geologic time.

Inclusion of geologic time into mathematical models is difficult. This is caused by the existence of both absolute and relative geologic time, which are totally different in nature. The origin (zero point) of the absolute time is identical for the entire Earth, whereas the relative time is determined using the stratigraphic and paleontologic techniques with no zero-point time count. It is not possible to use the relative geologic time in mathematical geologic models. An opinion that the absolute time cannot be used as the input parameter in mathematical modeling of dynamic geologic systems is totally ungrounded.

Description of a geologic system or selection of the mathematical tools for modeling depends on the nature of system studied (mainly on its complexity and organization). Geologic systems belong to the realm of complex and supercomplex, poorly organized (non-uniform) natural structures. The stochastic-statistical techniques used predominantly in modeling static geologic systems cannot be used in modeling dynamic systems, where time is the major variable (the geologic time is measured in millions of years).

A possible approach to modeling dynamic geologic systems involves mathematical analysis techniques, i.e., differential equations, in combination with stochastic-statistical methods of assigning the numeric values of variables. On the one hand,

this approach allows a deterministic analytical description of major features in the evolution of a geologic system. On the other, it enables one to consider the stochastic-statistical nature of various geologic parameters (variables) causing changes in the system. The analytical solution can be obtained by using the Monte Carlo technique. This synthetic approach allows one to solve numerous theoretical and practical problems in petroleum geology (Buryakovsky et al., 1982, 1983).

The proposed general classification (Table 1.1) identifies the following major features of the geologic systems. These systems belong to the natural or natural-engineering systems on a scale ranging from sublocal to global, and are complex to supercomplex. In terms of their evolution in time, they are usually dynamic (in some specific cases, they are static). Interaction with the environment is achieved through the exchange of matter, energy, and information. Available information of the system depends on the stage of the system's exploration and may range from zero (when the system has not yet been identified) to complete quantitative information. For the description of a system, any modeling techniques can be used.

Theoretical studies in geology have the objective of cognition of real geologic systems as well as development of the theories of geologic processes that result in the studying of existing system and transformation of one system into another.

TABLE 1.4

System of scientific knowledge and scientific activity

Subsystem	Type of knowledge	Logical form	Type of inference	Logical estimate
Theory (T)	Knowledge of laws of nature, function and evolution of objects	Sentence	Deduction	True/False. Definite set of parameters
Fact (F)	Knowledge of properties of and interrelations among the objects selected for experiment	Sentence	Induction	True/False. Indefinite set of parameters
Method (M)	Knowledge of procedures required for acquiring new knowledge	Standard		Implemented or unimplemented
Subject (S)	Formulation of purposes and objectives of cognition	Question	Intuition	Feasible or unfeasible
Result (R)	Knowledge of properties of, interrelation among, and evolution of objects expressed in subsystems T, F, M, S at the new cognition level	Sentence		True/False. Definite set of parameters

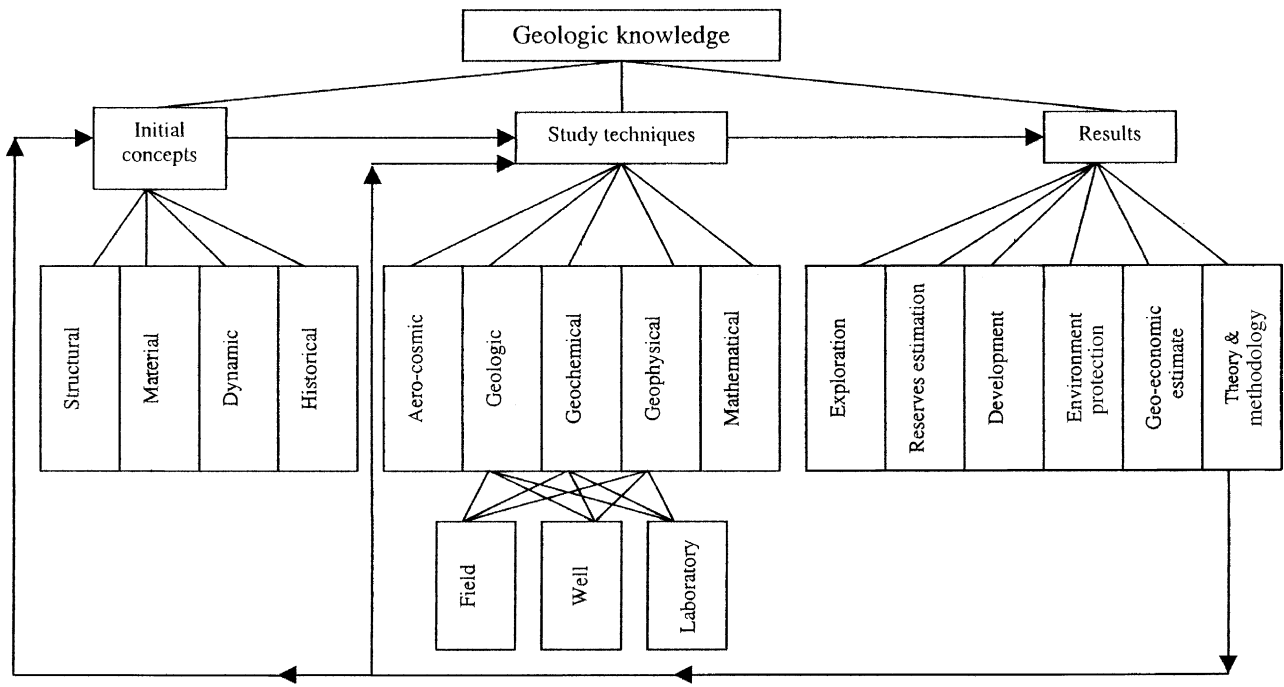

Fig. 1.2. Flowchart of geologic knowledge system.

Following the general scheme of scientific knowledge (Table 1.4), a schematic image of the construction of geologic knowledge or geologic theory was developed (Fig. 1.2).

Subsystem **T** (Theory) includes *a priori* geologic concepts covering such fundamental properties of geologic systems as their structure, material composition, dynamics (function), and history.

Subsystem **M** (Method) is subdivided into a number of purely geologic study techniques and those adapted from other scientific disciplines.

Subsystem **F** (Fact) is the derivative of two subsystems described above and includes results of experimental and field observations (measurements) conducted in various ways according to *a priori* set of geologic concepts.

Subsystem **S** (Subject) is the assignment of goal for the study of specific geologic bodies. The primary models of geologic bodies obtained as a result of direct observations and measurements (maps, profiles, cross-sections, tables, graphs, etc.) should be understood and accepted as a subject in geology.

Subsystem **R** (Result) contains the newly derived knowledge that either enters directly as a practical implementation or serves as a further development of theoretical and methodological concepts (*a posteriori* theoretical concepts).

The system of oil and gas reserves estimation may serve as an example of construction of geologic knowledge system. It includes the following five subsystems:

- (1) Geologic conditions of subsurface reservoir occurrence: type of traps, structural elements, depth of occurrence, type of reservoir, type of reservoirs, type of sealing rocks, type of hydrocarbon accumulation, and type of formation fluids.
- (2) Reservoir structure and parameters: folding and faulting features, porosity, permeability, fluid saturation, wettability of rocks, and compressibility.
- (3) Reservoir drive mechanism: solution gas drive, gravity drainage, water drive, gas-cap drive, compaction drive, or combination drive.
- (4) Hydrocarbon reserves estimation: volumetric, statistical and material balance techniques.
- (5) Evaluation of effectiveness of reserve estimation: accuracy of estimate, reliability of reserves, proportion of various reserve categories, and value of reserves.

Thus, the in-place and recoverable reserves are estimated based on the detailed simulation of oil and gas reservoir. The estimated amount of reserves is used for justification of capital investments in oil and gas field development and production. The reserve estimation system is a key step dictating the transfer from exploration to production. Geologic system “oil and gas reservoir” at the stage of production is transformed into geologic-engineering system (“producing oil and gas reservoir”).

This page intentionally left blank

Chapter 2

OIL- AND GAS-BEARING ROCKS

2.1. COMPOSITION OF OIL- AND GAS-BEARING ROCKS

A leading role in the rock–water–organic matter system belongs to rocks. The rocks containing oil and gas alternate in the Earth’s crust with the rocks that do not contain hydrocarbons. The former rocks are called petroleum sequences or petroleum systems. Such sequences in the sedimentary cover comprise a relatively limited combination of rocks, but form numerous diverse combinations. Eremenko and Ulyanov (1960) identified 15 individual lithofacies among the sedimentary rocks:

1. Limestones, dolomites.
2. Limestones and dolomites with clay (shale) interbeds.
3. Limestones and dolomites with sand (sandstone), and clay (shale) interbeds.
4. Clays (shales) with limestone interbeds and lenses.
5. Clays (shales) and sandstones (sands) with limestone (dolomite) interbeds.
6. Clays with limestone (dolomite), sandstone (sand), and marl interbeds.
7. Clays (shales) and marl with sandstone and sand interbeds.
8. Clays (shales) with sandstone and sand interbeds and lenses.
9. Clays (shales) with sand, sandstone, and conglomerate interbeds.
10. Sandstones with conglomerate interbeds.
11. Sandstones and sands.
12. Coaliferous sediments.
13. Salt- and gypsum-bearing sediments (evaporites).
14. Variegated (showing variations of colors or tints) sediments.
15. Flysh facies.

Sometimes, highly compacted (devoid of intergranular, effective porosity, and permeability) fractured rocks are encountered. Oil can only move through fractures in such rocks. The production of oil and gas found in the matrix of such rocks is practically impossible. Thus, an additional group of petroleum sequences is the tight fractured rocks. Another group is formed by the volcanic and metamorphic rocks, which often contain oil and/or gas in fractures and, sometimes, in vugs and caverns formed by weathering and dissolution.

A term “geologic formation” gained common acceptance during the recent years. This well-forgotten term was introduced by Abraham George Werner as far back as in 1781. Khain (1973) defined formation as follows: “...a formation is a natural and regular combination of rocks (sedimentary, volcanic, intrusive) related by the common environment of their origin and emerging at certain evolutionary stages of the major structural zones in the Earth’s crust”.

Based on this definition, the lithofacies listed above may be considered as formations. Generally speaking, if we treat facies as an environment in which rocks were formed, it is possible to view formations as the product of such environments.

The most common lithofacies are: limestones and dolomites (1); and clays (shales) with sandstone and sand interbeds (2). Less common are the petroleum sequences, which are formed by such lithofacies as sandstones with conglomerate interbeds (10), and clays (shales) with limestone interbeds and lenses (4). Most common facies are marine sedimentary sections, the coaliferous facies, and the variegated deposit facies.

Petroleum sequences composed of carbonate lithofacies (1–3) prevail on the platforms. Sequences comprising sandy–clayey lithofacies with carbonates (4–5), and sandy (10–11), variegated (14), coaliferous (12) and salt-bearing (13) lithofacies are about equally represented on platforms and in geosynclines (including foredeeps). Petroleum sequences composed mostly of clayey (6–9) and flysh (15) lithofacies are found predominantly or exclusively in geosynclines (including the foredeeps).

It terms of their occurrence, Bakirov (1976) subdivided petroleum sequences into:

- (a) regional (i.e., developed within the entire petroleum provinces or their major regions),
- (b) subregional (i.e., developed within individual areas of petroleum provinces or regions)
- (c) zonal (occurring in an oil and gas generation zone), and
- (d) local (found within individual oil or gas fields).

With respect to the fluids contained in a petroleum sequence, the rocks may be subdivided into two classes, reservoirs and seals (caprocks), with numerous transitional forms. This is a rather tentative classification as one and the same rock can behave differently toward different fluids. For instance, most clays permeable to water (although sometimes with great difficulty) are impermeable to oil and gas. Some water-saturated clays are permeable to oil but impermeable to gas (capillary pressure at the gas–water contact is higher than at the oil–water contact). Hydrophilic rocks with small pores prefer water to oil, whereas hydrophobic rocks behave conversely. Depending on subsurface temperature and pressure, the salts may either act as seals or reservoirs. Fluid flow through a rock depends not only on the rock properties but also on fluid properties, which are very sensitive to changes in the temperature and pressure.

2.2. RESERVOIR ROCKS

Oil and/or gas reservoir rock is understood as not only a rock that can contain but also yield these fluids during the development and production in a given temperature–pressure and geochemical (physicochemical) environment. The latter statement is very important in preventing a researcher from using the various reservoir-rock properties obtained in the laboratory. Even those determinations obtained at reservoir conditions should be taken with a grain of salt, if the core was first exposed to surface conditions. Physical and chemical conditions may cause alterations, such as irreversible precipitation of salts out of solution (water, oil, gas) or, conversely, dissolution of salts, etc. One must keep in mind that most of such processes exhibit hysteresis. Exposure to air (oxidation) also changes the wettability of rocks (oil-wet versus water-wet). Logs can provide continuous record of petrophysical properties,

which can be compared to those obtained by core analysis. Seismic surveys enable one to determine some rock parameters even without drilling the wells.

Important characteristics of reservoir rocks are their capacity to contain certain volume of oil and/or gas and their capacity to yield oil and/or gas. The first characteristic is defined by porosity and the second one by permeability.

2.2.1. Porosity

The total volume of void space in the rock, including pores, vugs, and fractures, is called the total or absolute porosity. Total porosity is the ratio of the total void volume to the bulk volume. It is expressed as a fraction or percentage.

Some pores are not interconnected. Such isolated pores are not involved in the fluid flow during the development and production. Besides, isolated pores may be filled up with water, oil, or gas (irreducible fluid saturation). So, the open porosity is identified as the ratio between the open pore volume and the bulk volume. Open porosity is always lower than the absolute (total) one.

Some pores and channels do not permit fluid movement and turn out to be ineffective due to their small diameter, wettability of the channel walls, and irreducible fluid saturation. Thus, the ratio of the effective pore volume to the bulk volume is called effective porosity (fraction or percentage). Effective porosity must be always determined for a specific fluid and for the specific reservoir conditions. It is equal to open porosity minus the irreducible fluid saturation. It may be determined by means of petrophysics (logs) or using special field studies.

Normalized porosity (void ratio), i.e., pore volume to rock matrix volume ratio, is sometimes used, especially in subsidence due to fluid-withdrawal studies. Porosity depends first of all on the grain size, packing, sorting, roundness, and the mineralogy and amount of cement. Porosity also depends on the occurrence and preservation of vugs and fractures formed as a result of secondary alterations, and on two inter-related phenomena, i.e., arch effect and transverse compression (Poisson's ratio).

Structure and texture of rocks strongly affect the geometry of the pore space. Structure of rocks means external features of rock grains (their shape, nature of surface, etc.). Texture includes the type of interrelations between the grains and their orientation. In particular, lamination is the most important and commonly used texture feature. Texture of the sedimentary rocks is born during sedimentation. Although post-depositional alterations can significantly affect the texture, recognizable features of the initial texture are usually preserved. Dmitriyevskiy (1994) called the ability of sedimentary rocks to preserve depositional features at depth "the sedimentary translation". In his publications, he developed main positions of that theory. There is a strong dependence of sedimentary translation on mineral composition, type of cement, and sediment thickness.

A significant influence on the interrelation between the rocks and fluids is the specific surface area. In clastic rocks, the specific pore surface area is inversely proportional to the grain size as follows:

$$s_p = 6(1 - \phi)/d \quad (2.1)$$

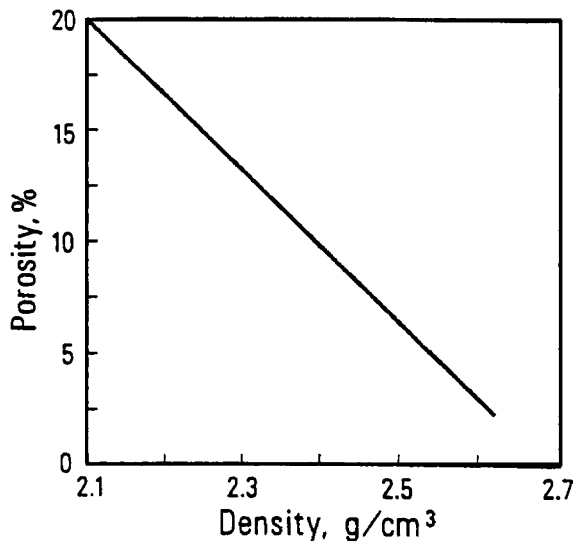

Fig. 2.1. Paleozoic sandstones, AR, USA. Relationship between porosity and density (In: Eremenko and Chilingar, 1996, p. 17.)

where s_p is the specific pore surface area (cm^2/cm^3 or cm^{-1}), ϕ the porosity (fractional), and d the average grain size (cm).

The density of sedimentary rocks ranges from 1.7 to 2.6 g/cm^3 . In clastic rocks, density is inversely proportional to porosity (Fig. 2.1).

Carbonate rocks often form oil and gas reservoirs (Bagritseva, 1977; Chilingarian et al., 1992, 1996). Reef buildups, calcarenites, and oolitic limestones all have primary porosity. This primary porosity substantially changes during diagenesis upon recrystallization, dolomitization, and leaching. The latter process is very important in the karst formation. The formation of karst can begin at the stage of early diagenesis and then continue during epigenesis (catagenesis), especially within highly fractured rocks. Unfortunately, vugs in vuggy limestones are often filled by the second-generation calcite and other newly formed minerals. Dolomitization processes can increase porosity up to 13.1%, whereas sulfatization and silicification can significantly decrease porosity. Porosity due to fractures alone is around 1%, whereas in the presence of vugs and cavities, porosity can reach 3.5%.

2.2.2. Permeability

Permeability is the ease of flow of fluids through rocks. The volumetric rate of flow is proportional to the pressure gradient:

$$Q = k \frac{A}{\mu} * \frac{\Delta p}{L} \quad (2.2)$$

where Q is the flow rate (m^3/s), μ the dynamic viscosity ($\text{Pa} \cdot \text{s}$), Δp the pressure gradient along the length L (in m, Pa/m), A the cross-sectional area (m^2), and k the permeability (m^2).

Permeability is a function of the pore size and shape, pore throat and/or channel diameter, grain size and shape, grain packing density, tortuosity, sorting, cementing, fracturing, and residual fluid saturation. The above definition of permeability indicates that its value should not be affected by the nature of a liquid moving through the porous medium. Actually, however, permeability changes depend on the type of flowing fluid. These changes are sometimes greater than 100%. According to definition, permeability also should not change with time. Experiments, however, often demonstrate permeability drop of up to 50% within 1 h. There are different explanations of the reasons causing permeability change in time, and the effect of fluid properties on permeability. If fluids flow through loose reservoir rocks that include some fine sands, rock grains may change their positions (a phenomenon called “suffusion”), and the pore channels may become plugged with fine material. Colloidal particles suspended in oil may precipitate and plug the pores. Resins and asphaltenes present in crude oil may also precipitate, and result in a decrease of the cross-sectional area of pore channels, throats, and canals. Wettability of rocks (oil-wet versus water-wet) also changes the relative permeability to water and to oil (see Chilingarian et al., 1992, 1996).

When water flows through reservoir rocks that include clay minerals, many of the clay minerals swell, which also results in a decrease in the cross-sectional area of pore channels. Water in contact with silica may give rise to colloidal silica in porous space, which may lead to plugging of the pore channels. When CO_2 is released from water, CaCO_3 precipitates within reservoirs according to the following reaction:

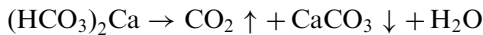

decreasing the pore throat and canal diameters.

Based on experiments, Khanin (1976) recorded a substantial decline in gas permeability of sandy rocks with the cement content of 4–10% (see also Fig. 2.2). Dutton and Diggs (1992) also reported drastic permeability changes in the Upper Cretaceous sandstones of eastern Texas having similar cementation ranges. Buryakovskiy (1985) provided quantitative relationships between permeability and cementation (both due to argillaceous cement and calcareous cement) based on laboratory analyses of cores recovered from the Pliocene Productive Series of the onshore and offshore Azerbaijan.

It is established that the Darcy’s law may be applied for the description of a steady fluid flow only within certain limits. The upper applicability boundary is associated with inertia forces at high velocity flow and is defined by the critical value of the Reynolds number ($Re_{cr} = 7.5\text{--}9$). The lower applicability boundary, typical for low-velocity flow (for instance, in clays) is associated with fluid interactions with the porous medium (non-Newtonian rheological properties of liquids). Some liquids (oil, water) can form colloidal films on the surface of a porous medium that may totally obstruct the liquid movements through the pores. In this case, in order for the movement to begin, an additional force should be applied (the initial pressure

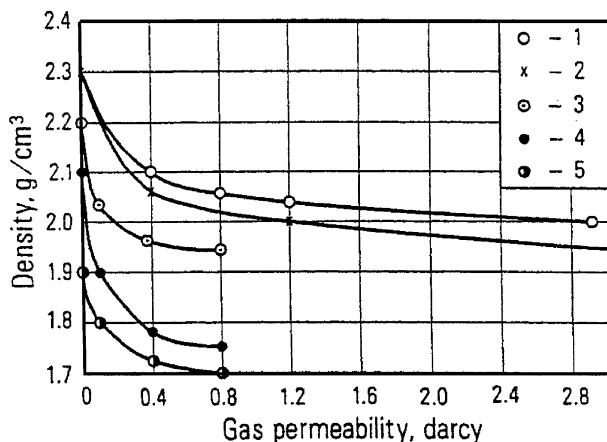

Fig. 2.2. Relationship between density and permeability to gas. 1—Devonian fine-grained sandstone of Pashiy Formation, Bashkortostan and Tatarstan; 2—Upper Permian Kazanian fine-grained sandstone of Buguruslan (Ufa) Formation, Tarkhanskoeye gas field; 3—Lower Paleogene siltstone of Abazy Formation, Akhtyrsko-Bugundyrskoye oil field; 4—Fine-grained sandstone of Maykop Formation, Krasnodar Region; 5—Siltstone of Khadum gas-bearing Formation, Stavropol Region, Russia. (After Khanin, 1976.)

gradient must be overcome). V. P. Savchenko (in: Eremenko and Chilingarian, 1991) proposed to call the pressure gradient at which the fluid flow begins the “break-through pressure”, and the pressure gradient at which the fluid flow stops, the “constriction pressure”. As in many other natural phenomena, this phenomenon displays hysteresis: the constriction pressure is always either less than the break-through pressure or close to it, but never greater: $p_{\text{constriction}} \leq p_{\text{breakthrough}}$. As an example, the writers of this book conducted experiments with the Dylm Paleogene shales and found that $p_{\text{breakthrough}} = 12 \text{ MPa}$ and $p_{\text{constriction}} = 8 \text{ MPa}$. For the much more compacted lower cretaceous shales, both pressures were equal to about 12 MPa.

Admixture of clay minerals significantly affects the formation of pore spaces in reservoirs. Klubova (1984) had determined that montmorillonite lowered permeability the most (the addition of 2% montmorillonite to a coarse-grained quartz sandstone lowered its permeability by a factor of 10, and the addition of 5% montmorillonite, by a factor of 30). At the same time, the very same sandstone with up to 15% kaolinite preserves fair permeability.

The montmorillonite behavior in pores depends substantially on the composition of ions located in its exchange positions. These ions control the amount of water and hydrocarbons penetrating interlayer spaces of montmorillonite’s crystalline grid. Klubova (1984) studied the effect of montmorillonite with different cations in its exchange positions on the permeability of quartz sand (grain size of 0.1 mm). Montmorillonites with Ca and Mg in the exchange positions influence permeability similar to H-montmorillonite. Addition of 5% (by vol.) of NH_4 -montmorillonite lowers permeability of the sand by a factor of 22, and Na-montmorillonite, by a factor of 33.

The fluid flow through the reservoir rocks is also affected by the type of clayey cement distribution in the pore space. On assuming uniform distribution of cement, the finer are the rock grains (and the poorer is their sorting), the greater is the effect of the clay, i.e., the more complex is the structure of pore space, the greater is the effect of the clay. Studies of thin sections of the reservoir rocks with different distribution of cement showed that the allothigenic minerals do not cover the clastic grains uniformly. Thus, they form peculiar swollen coagulants on the salient parts of rock-forming minerals and convert initially large pores into small, dead-end ones. When the clay cement is uniformly distributed, the number of dead-end pores is very high and the intercommunicating pores become geometrically complex. This hampers the movement of oil through the reservoir. The greater the amount of a clay, the more complex are pore outlines, and the more constricted is the fluid flow through the reservoir.

The effective pore diameter in a reservoir with clay cement decreases also due to sorption of some portion of hydrocarbons on the active centers of clay minerals. High-molecular-weight hydrocarbons are especially prone to be sorbed.

Correlation between the two major reservoir parameters, porosity and permeability, is a difficult task. Permeability correlates most closely with the size and shape of pores, whereas porosity does not depend on the pore size. Numerous attempts have been undertaken to theoretically determine the correlation between the porosity and permeability. Sometimes, the specific surface area is used. F. I. Kotyakhov (in: Eremenko and Chilingarian, 1991) proposed the following equation:

$$k = 49 \times 10^6 \phi^3 / s_p \quad (2.3)$$

where s_p is the specific pore surface area (cm^2/cm^3), k the permeability (cm^2), and ϕ the porosity (fractional).

Levorsen (1967), in turn, proposed the following equation:

$$k = 2 \times 10^{-7} \phi^3 / (1 - \phi^2) s_p^2 \quad (2.4)$$

Buryakovsky (1985) provided quantitative relationships between permeability and porosity based on laboratory analyses of cores recovered from the Pliocene Productive Series of the onshore and offshore Azerbaijan.

A fuzzy correlation is illustrated by experiments conducted by Kerans et al. (1994) on outcrop samples of Permian carbonates with leaching pores (Fig. 2.3). A log-log graph shows some correlation between the porosity and permeability at porosity below 20%.

Presence of a fracture in the rock drastically increases its permeability and only slightly affects the porosity (Bagrintseva, 1977; Chilingarian et al., 1992, 1996). The liquid flow velocity through a fracture is determined by the Boussinesq equation:

$$V = \frac{w^2}{2\mu} \Delta p \quad (2.5)$$

where w = the fracture opening, μ = the viscosity, and Δp = the pressure drop.

For a laminar gas flow, taking gas compressibility into account, Eq. 2.5 can be presented in the following form:

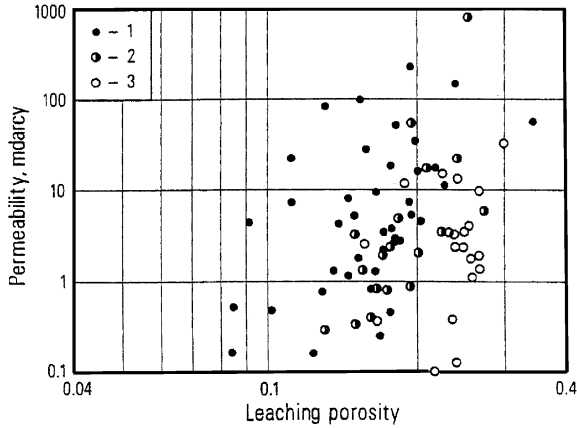

Fig. 2.3. Permian carbonate outcrops. Relationship between the permeability and porosity due to dissolution (leaching) (after Kerans et al., 1994). Porosity (%): 1–0.5; 2–6–10; 3–11–30.

$$V_g = \frac{k}{2\mu} \Delta p^2 \quad (2.6)$$

where k is the gas permeability.

If the fracture opening is at least $10 \mu\text{m}$, fractured reservoir permeability may be calculated using the following equation:

$$k = 8.5 \times 10^{-4} w^3 / b \quad (2.7)$$

where b is the spacing between the fractures (m).

The classical hydrodynamic equation for narrow linear channels (fractures) is

$$q = w^3 a \Delta p / 12 \mu L \quad (2.8)$$

where q is the volumetric rate of flow (cm^3/s), w the height of fracture (cm), a the width of fracture (cm, [$a \gg w$]), L the length of fracture (cm), Δp the pressure drop (dyn/cm^2), and μ the viscosity (dyn/cm^2).

For laminar flow, Witherspoon et al. (1980) proposed the following equation:

$$q = 5.11 \times 10^6 (w^3 \Delta p a / l \mu) \quad (2.9)$$

where q is the volumetric rate of flow in (bbl/day), w the width (or aperture) of a fracture (in); Δp the pressure drop (psi), a the width of fracture face (f), l the length of the fracture (f), and μ the viscosity of the fluid (cP).

Jones et al. (1988) suggested the following equations for open, rough fractures with single-phase flow:

$$q = 5.06 \times 10^4 a (\Delta p w^3 / f l \rho)^{0.5} \quad (2.10)$$

$$k = 5.39 \times 10^5 \mu (w l / \Delta p \rho)^{0.5} \quad (2.11)$$

where q = the volumetric rate of flow (bbl/day), k = the permeability (darcys), ρ = the density of flowing fluid (lb/ft^3), and f = the friction factor (dimensionless).

Detailed procedure of determining friction factor (f) is discussed by Chilingarian et al. (1996, pp. 4–8).

If permeability of porous reservoir rocks is proportional to the square of pore diameter, in fractured ones it is proportional to cubed fracture opening.

A very good correlation between the porosity and permeability was established by Chilingarian et al. (1992) by introducing two additional variables, irreducible fluid saturation and specific surface area.

If fractures form in an anisotropic (laminated) medium, its permeability will differ in different directions. Moreover, in some cases both porosity and permeability near the fracture may significantly decrease. Studies conducted by Antonellini and Aydin (1994) on samples from outcrops in the Utah National Park indicated that permeability and porosity in the fault zone drops almost to zero (Fig. 2.4). Within the compaction zone further from the fault porosity was less than 10% and permeability was about 10 mD. Farther out, at a distance of just 5–6 mm, porosity was 26% and permeability was 1,200 mD (average matrix values).

Fig. 2.5 displays permeability change in the direction perpendicular to the lamination. Within the narrow zones adjacent to the destruction zones, the parallel permeability $k_{||}$ shows positive peaks, whereas the perpendicular permeability k_{\perp} displays negative peaks, i.e., a decrease in the destruction zone.

Thus, not every fault causes an increase in porosity and permeability. In the transition zone from the elastic to the plastic deformation, a decrease in both porosity and permeability is observed. Drastic permeability anomalies emerge at the boundary between plastic and rupturing deformations. Depending on the lithology, direction, and type of the fault, these anomalies may have different signs. Permeability and porosity in fault zones also depend on the conditions and the extent of

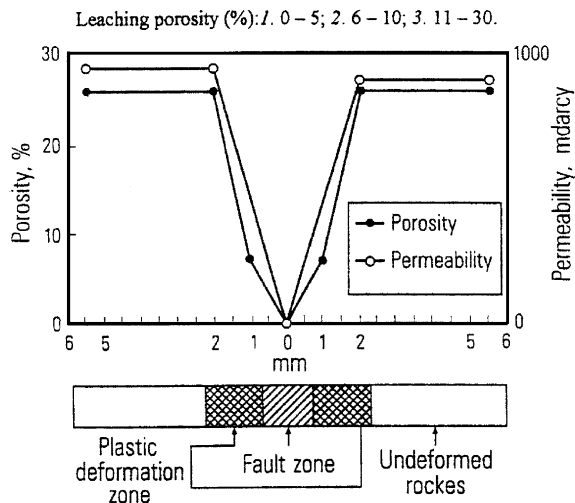

Fig. 2.4. Mesozoic Entrada sandstone, UT, USA. Permeability and porosity across a fault zone (after Antonellini and Aydin, 1994). (Courtesy of the American Association of Petroleum Geologists.)

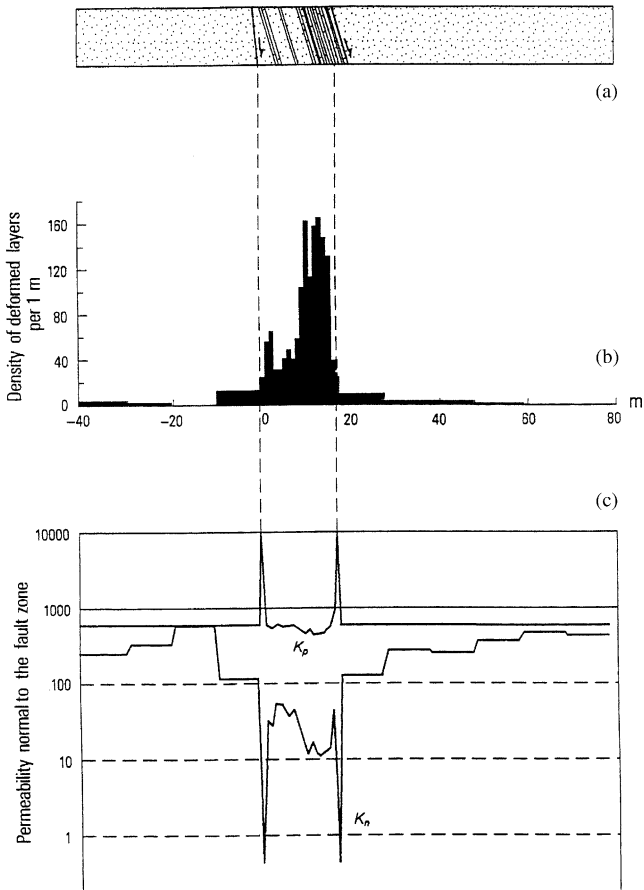

Fig. 2.5. Mesozoic Entrada sandstone, UT, USA: (a) schematic cross-section of the fault zone; (b) histogram of the number of deformed layers (deformed bonds) per meter; and (c) calculated average permeability over a distance of 1 m (after Antonellini and Aydin, 1994). Deformed layers (deformation bands) are 1.5 mm thick. Permeability of the wall rock is 0.005 mD; k_n is the permeability normal to the fault; k_p is the permeability parallel to the fault; fault location: Delicate Arch Trail; total offset across the fault is 40 m. (Courtesy of the American Association of Petroleum Geologists.)

filling of pores and fractures as a result of re-crystallization and secondary cementation.

Beside clastic and carbonate rocks, reservoirs may be composed of volcanic rocks, volcanoclastic rocks, and shales. Oil accumulations in such reservoirs are found in many countries (Azerbaijan, Turkey, Cuba, USA, Indonesia, etc.)

Reservoir properties of rocks are most commonly encountered in the ultrabasic, basic, and medium extrusive rocks, and rarely, in rhyolites. Volcanoclastic and mixed volcanic-sedimentary reservoirs are quite common. Effective porosity in such reservoirs is sometimes associated with intergranular pores and vugs, but, as a rule, with fracturing. An important role in the formation of reservoirs included in this group

belongs to the fractures formed as a result of weathering and leaching (in particular, hydrothermal leaching). High-quality reservoirs in such sequences, however, are sporadic. One may encounter very diverse oil flow rates in the adjacent wells, from almost nil in one well to a few thousand tons a day in the next one.

Shaly sequences are very common. The shales serve as a confining medium or local seal, whereas the reservoir rocks within the shales consist of lenses and interbeds of sands, sandstones, and carbonates. At the beginning of the 20th century, oil and gas flows were obtained from fractured schists in California, in some other areas of the world, and from the bituminous shales of Bazhenov Formation in western Siberia. As a rule, shales serving as reservoir rocks were significantly altered during catagenesis and are in effect in-between shales and schists. Klubova (1984) stated that these shales/schists “are mostly composed of illite, include significant amounts of dispersed organic matter, and are silicified. Commercial capacity of these rocks is due to the presence of a rigid silica frame and of organic matter sorbed by clay minerals. Organic matter makes the surface of clay mineral monocrystals hydrophobic, thereby making the contacts between these crystals and with other rock microcomponents easy to separate, with subsequent release of the contained oil”.

With respect to the Bazhenov shales in particular, Klubova concludes that microtextural non-uniformity of the Bazhenov shales results in the presence of weakness zones and resulting porosity. Zones of weakness are clearly observable in thin sections and are sometimes misinterpreted as fractures. The separation of the rocks along these zones of weakness causes rock fragmentation, i.e., leads to the same results as fracturing. Despite a rather rigid silica frame in Bazhenov shales, their plasticity is quite high, resulting in a low degree of fracturing (<10 fractures/m) (Klubova, 1984).

Zones of weakness in the Bazhenov Formation have been finalized at the diagenetic stage, whereas the separation of these zones and the appearance of porosity (fractures) occurred in tectonically active areas during the catagenetic stage (Klubova, 1984).

Of course, the catagenesis (or epigenesis²) affects the reservoir properties not only of shales but also of many other reservoir rocks. A systems treatment involves an analysis (effects of individual factors) first and, then, synthesis. Before doing this, however, one must review one more component of petroleum sequences, namely, seals (caprocks).

2.3. CAPROCKS

For a long time, the only force causing the movement of oil and gas in the subsurface was believed to be buoyancy. If so, then to form oil and gas accumulation, their migration paths must have been stopped by a roof, i.e., caprock (seal). Clays, shales, carbonates, evaporites, and their combinations can form caprocks. Dobrynin

²Epigenesis includes all processes that affect already formed sedimentary rocks after diagenesis.

and Serebryakov (1989) determined that the lowermost limit of permeability in the reservoirs was 10^{-15} – 10^{-16} m², whereas the permeability in young argillaceous caprocks was 10^{-20} m².

The same rocks react differently to different fluids. In some cases, rocks serve as satisfactory or good conduits for water, but form barriers for oil or gas movement. In some other situations rocks yield oil but stop gas movement, etc. This is determined by capillary forces, the magnitude of which depends on fluid and rock properties (fluid density, fluid viscosity, rock structure, rock wettability) and pore size (capillary forces almost disappear when the pore diameter exceeds 0.5 mm). According to the Laplace's law,

$$p_c = 2\delta/r \quad (2.12)$$

where p_c = the capillary pressure, δ = the surface tension, and r = the surface curvature radius (at a pore diameter < 0.1 mm). For fractures, the equation has the following form:

$$p_c = 2\delta \cos \alpha/w \quad (2.13)$$

where w is the fracture opening (width) and α is the contact angle.

All aforementioned rock and fluid properties are strongly affected by the subsurface temperature and pressure and geochemical environment.

The writers propose the following definition of caprock: caprock is a rock that prevents the flow of a given fluid at a certain temperature and pressure and geochemical conditions. Therefore, the necessary properties of a rock to act as a seal will be different for different fluids. The same rock with different fluids may or may not have sealing properties up to a complete inversion (caprock → reservoir). I. M. Mikhailov, B. I. Yakovlev and N. A. Eremenko (in: Eremenko, 1978) proposed the following three types of caprocks.

Type I caprocks are typical for argillaceous sequences in a state of continuing compaction; they are developed in areas of young subsidence of Earth's crust, with abnormally high pore water pressure. Sealing properties of these rocks are determined by the amount of capillary pressure at the contact of the reservoir and caprock, the pore pressure of water saturating the caprock, initial pressure gradient of water and the variation of hydraulic forces in the section. Sealing property, or caprock breakthrough potential ($P_{\text{breakthrough}}$), may be presented as follows (Fig. 2.6):

$$P_{\text{breakthrough}} = P_b = P_{\text{pw}} + P_c + G_w \alpha h \quad (2.14)$$

where P_{pw} = the maximum pore water potential in caprock, P_c = the capillary pressure of breakthrough into the caprock, G_w = the initial water pressure gradient in caprock, h = the seal thickness, and

$$\alpha = \frac{1}{2} \left(\frac{P_{\text{w.u.layer}} - P_{\text{w.l.layer}}}{G_w h} + 1 \right)$$

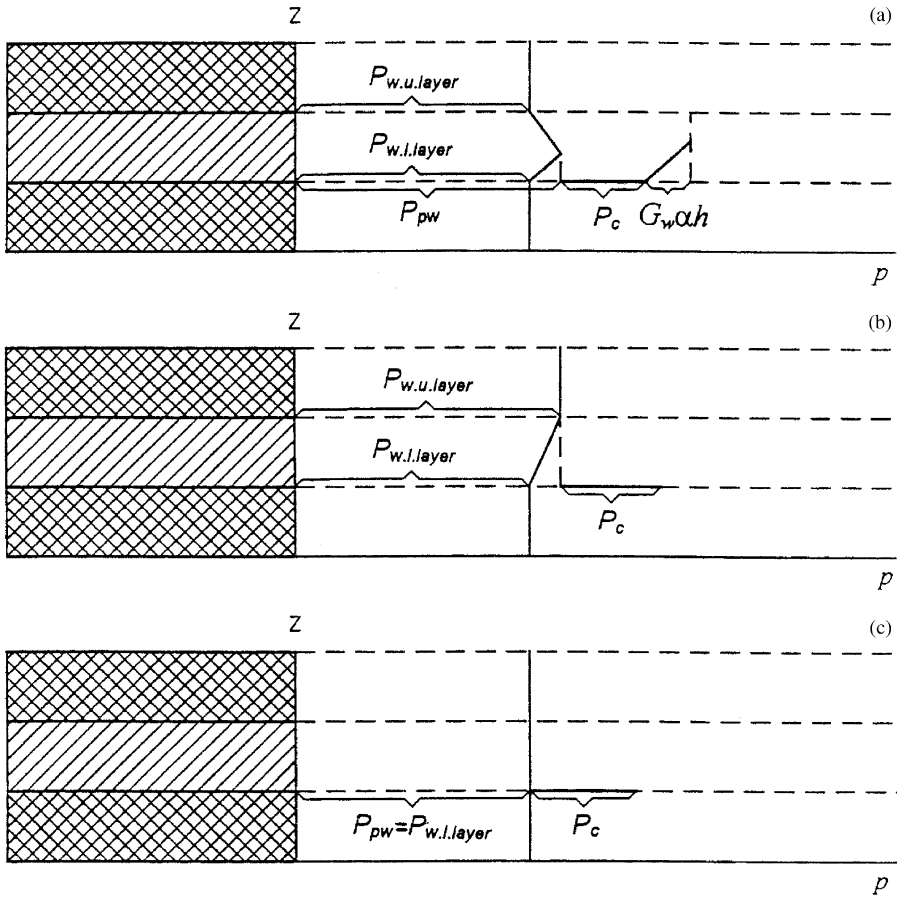

Fig. 2.6. Diagrams of caprock breakthrough potential: (a) Type 1; (b) Type 2; and (c) Type 3. (In: Eremenko and Chilingar, 1996.)

is the coefficient determining the distance between the base of the caprock and the surface of maximum pore pressure. In this expression, $P_{w.u.layer}$ and $P_{w.l.layer}$ are, respectively, the water potentials of the upper and lower layers.

Oil and gas accumulations have higher potential energy than that of the formation water. These accumulations can be stable only if this energy is equal to or less than the caprock breakthrough energy, i.e., $P_b \geq P_a$, where P_a is the total potential energy of the accumulation. Total potential energy of the accumulation may be determined from the following equation:

$$P_a = P_{wr} + \int_0^h \Delta\gamma(h)H - G_o H \tag{2.15}$$

where P_a = the total potential energy of the accumulation, P_{wr} = the water potential in the reservoir rock, $\Delta\gamma$ = the difference in fluid densities, G_o = the initial oil pressure gradient in the reservoir rock, and H = the height of accumulation column.

Maximum possible height of accumulation column may be determined from equality of the breakthrough potential and the accumulation energy by solving together the above two equations. Provided the reservoir fluid densities are constant, the maximum height (H) of the oil column is equal to

$$H = \frac{P_a - P_{wr} + G_o \alpha h + P_c}{\Delta\gamma - G_o} \quad (2.16)$$

Pore water pressure in compacting argillaceous beds is always greater than the pressure in the adjacent reservoir beds. As a result, sealing capability of the Type I caprocks is determined by hydraulic sealing, by the amount of capillary pressure, and by the pressure at which water begins to flow through caprocks. Just the capillary pressure alone in such caprocks (groups A and B, of Khanin, 1976) may exceed 100 kg/cm². This means that the Type I caprocks is capable of confining an oil accumulation having almost any column height. Dobrynin and Kuznetsov (1993, p. 106) proposed the following correlation between the accumulation column height Δh_a and caprock thickness Δh_{seal} :

$$\Delta h_a = f(\Delta h_{seal}) \quad (2.17)$$

where f depends on temperature. At 40°C in gas accumulations, $f \geq 4$, whereas in oil accumulations, $f \geq 17$. At 60°C in gas accumulations, $f \leq 2$ and in the oil accumulations, $f \leq 7$.

It appears that a statement by Buryakovsky et al. (1990, p. 186) that “sealing capability of argillaceous caprocks does not depend on their thickness” describes only the aforementioned caprock type. Similar statements were made by Kontorovich et al. (1975) and Nesterov and Rylkov (1986).

Type II caprocks are associated with rocks compacted beyond the plasticity limit and having lost ability to swell on contact with water. Such rocks do not contain swelling clay minerals, and interstitial water contains surfactants. Consequently, pore water in these rocks does not have initial pressure gradient. This type of caprocks is encountered mostly in the Paleozoic and Mesozoic sediments of young and old platforms. There are no clear-cut overpressure environments there, but there is a relatively clear hydrodynamic subdivision in the section. The breakthrough potential (P_b) for the Type II caprocks is a sum of capillary pressure (P_c) and hydrodynamic forces:

$$P_b = P_{w.u.layer} + P_c \quad (2.18)$$

where $P_{w.u.layer}$ is the water potential of the upper layer (i.e., layer above the caprock).

Maximum accumulation column height H can be determined as follows:

$$H = \frac{P_{w.u.layer} - P_{w.l.layer} + P_c}{\Delta\gamma - G_w} \quad (2.19)$$

Eq. 2.19 shows that the hydrodynamic environment may improve or lower the sealing capability of caprocks. In an extreme case, the water potential in the reservoir may exceed the water potential of the bed overlying the caprock by the value of capillary pressure (P_c). In such a situation, the caprock will be open for the vertical flow of hydrocarbons, and the trap will not exist even when potential distribution in the reservoir bed is favorable.

Type III caprocks are typical for rocks with a rigid matrix and intense fracturing. Such caprocks are mainly developed over the old platforms in regions of low tectonic mobility, with no detectable hydrodynamic breakdown of the section. Formation water potential in such regions is practically equal throughout the section and corresponds to the calculated hydrostatic potential. The breakthrough potential for such caprocks is determined solely by the capillary pressure:

$$P_b = P_{wr} + P_c \quad (2.20)$$

The possible height of accumulation column is

$$H = \frac{P_c}{\Delta\gamma - G_o} \quad (2.21)$$

The equation above indicates that even at a low capillary pressure the accumulation column height may be significant when G_o is close to $\Delta\gamma$ (the gradient of Archimedes buoyancy force). If these gradients are equal, the accumulation may be preserved even in the absence of a definitive lithologically identifiable caprock. P_c in the equations above may be calculated using the Laplace equation.

Major conclusions from the studies of correlation between clay mineralogy and their sealing properties have been summarized by Klubova (1984) as follows:

The permanency in the composition of the silicate layer is a characteristic of the kaolinite group minerals. As a result, replacements within the lattice are very rare and the charges within a layer are compensated. The connection between silicate layers in the C-axis direction is implemented through hydrogen atoms, which prevents the lattice from expanding, ruling out the penetration of water and polar organic liquids.

The silicate layer in the montmorillonite mineral group is variable due to a common isomorphous replacement in octahedral and narrower tetrahedral sheets. This replacement results in the disruption of the lattice neutrality. Extra charge that occurs with such replacements is compensated by exchange ions. Ion properties that maintain lattice neutrality in montmorillonite minerals (valence, size of the ion radius, polarization, etc.) define the capability of the lattice to expand along the C-axis. As a result, water and polar organic liquids can penetrate the interlayer spaces. This, in turn, leads to an increase in the volume, which drastically lowers permeability and some other properties, but at the same time improves sealing capabilities.

The silicate layer of the illite mineral group is similar to the montmorillonite one. However, the excessive negative charge of the lattice is due mainly to the isomorphous replacements within tetrahedral sheets. The proximity between the source of negative charge and basal surfaces causes a stronger connection between the silicate layers of illite group compared to montmorillonite's.

Admixture of sand and silt degrades the sealing properties of clays. Especially important are the textural changes due to this admixture.

Not only the mineral composition of a rock and organic matter content, but also the pore water are important in forming the major sealing properties of clays, such as

degree of swelling and compressibility. The relatively low-temperature pore water is retained in argillaceous rocks up to a temperature of 100 °C to 150 °C. The temperature of water removal is higher when the concentration of dissolved components is higher. Pore water is located within pores of argillaceous rocks, and at the surfaces and along the edges of individual microblocks and microaggregates that comprise clays. The interlayer water causes swelling in montmorillonites and in degraded illites.

The order in water molecules positioning, relative to the clay–mineral blocks and aggregates, is rapidly altered with an increase in distance between these blocks and aggregates. Thus, a very important information for the evaluation of the role water plays in the formation of sealing properties is the knowledge of the structural status of the layer in an immediate contact with the particles' surface, and the role the cations having different charge density play in the preservation of water molecules' structure.

Exchange ions play a leading role in the formation of “water clouds” around microaggregates and microblocks of montmorillonite minerals and an insignificant role, with kaolinite minerals. The role played by the illite group minerals occupies an intermediate position.

Carbonates caprocks include micro- and fine-grained, massive and laminated limestones. Almost all limestones are dolomitized to some extent and are subject to fracturing. This adversely affects their sealing properties (Bagrintseva, 1977). Carbonates with a substantial clay content have laminated texture. As a rule, this results in a deterioration rather than an improvement of sealing properties due to the emergence of weakness zones at the contact between different lithologies.

Evaporite seals, which are common, include salt, anhydrite, and sometimes shales. It is a common (and probably erroneous) belief that such seals are the best and most reliable. Brittleness of these rocks at the surface conditions contradicts that belief. Besides, cores recovered in the Dnieper-Donets Basin and North Caspian Basin display macro- and microscopic fractures, which sometimes cut monolithic salt crystals. The fractures may be healed by secondary salt, but often contain traces of oil and sometimes gas bubbles. Sometimes core samples are completely saturated with oil. Permeability measured at the surface conditions can reach 100–150 mD and even higher. It was established, however, that these rocks easily become plastic even at a relatively low hydrostatic or, even, uniaxial pressure (<100 MPa) and the properties change with temperature. Allen and Allen (1993, pp. 364, 368) considered plasticity as an important sealing property. In this connection, they believe that salt has the best sealing properties. They also believe that the reliability of caprock is not directly related to its thickness.

Thus, properties of evaporites as seals change widely during the catagenesis (and in time). Similar changes also affect the other types of seals albeit not so obviously. Inclusions, such as organic matter, silt, clay or carbonate particles degrade sealing properties of evaporites due to the formation of zones of weakness around such inclusions (Klubova, 1984). A careful study of numerous logs from Dnieper-Donets Basin showed the presence of clay interbeds between the top of accumulation and the evaporite sequence in all cases. It appears that these interbeds in most cases act as caprock.

2.4. OIL AND GAS RESERVOIRS

The natural subsurface reservoir is a container of oil, gas, and water where they can move, and its shape is determined by the relationship between the reservoir rock and its surrounding poorly permeable rocks (Brod, 1950, 1957). Levorsen (1967) defines the subsurface reservoir as only that part of the reservoir rocks where the oil and natural gas can form an accumulation. Many authors tend to tie the notion of oil and gas reservoir to its content of hydrocarbons (Trofimuk et al., 1980; Kuznetsov, 1992). This appears redundant to the writers because the presence of oil or gas is not a vital property of the subsurface reservoir. The natural reservoir remains as such regardless of the type of the contained fluids, or even if it is dry. A comparison can be made with the overpressure. The presence of fluids is necessary for the overpressure. No fluids of different densities, no surplus pressure. As for the reservoirs, the writers agree with Kuznetsov who stated that “they possess two important attributes: spatial limitation (which determines the volume and boundaries of the reservoir), and an internal structure that defines the type and nature of inter-reservoir migration” (Kuznetsov, 1992, p. 15).

Indeed, these properties should be included in any definition of the reservoir as well as in the classifications being developed. Some attempts have been made to classify the oil and gas reservoirs on the basis of their relative size (local, zonal, basin-wide, regional, etc.) (Burlin et al., 1976; Kontorovich, 1991) or their absolute size (Weber, 1986; Allen and Allen, 1993).

Three types of reservoir limitations can be identified:

- reservoir roof
- lateral, and
- reservoir base (bottom).

The reservoir roof (top) may cover the reservoir (1) in normal stratigraphic succession, (2) with some depositional hiatus, and (3) may change its age along the strike. It is improbable but not impossible that a reservoir may be capped by the surface of an impermeable overthrust. It should be kept in mind the selectivity toward different fluids by caprock and a possibility of its transformation into a reservoir rock during epigenesis. Consequently, it is always important to indicate the exact nature of the fluid. The transformation of the caprock into a reservoir rock results in either disappearance of the reservoir or its conversion into a new reservoir (if there is another caprock above).

Lateral limitations are caused by lithologic alterations (including cementation) and the permeability. Small accumulations may be laterally limited by faults. This is possible, but not typical, for the larger reservoirs, because the fault zones in their evolution can become migration paths for various fluids (oil, water, or gas). Fault zones are actually “communication windows” with the other reservoirs.

The importance of the presence of the base (bottom) as a necessary reservoir component was not always clearly recognized, because it was believed that the accumulations were formed exclusively by the buoyancy (Archimedes forces). One must always keep in mind that the reservoir is an inseparable part of the hydrodynamic system. This system may be open or with a restricted communication to the

surface (artesian), or of “elision” type (i.e., with an inverse pattern of hydrostatic pressure). It is not possible for such energy system to exist without a base (bottom).

Often, no distinction is made among the terms: “reservoir rock”, “reservoir”, and “trap”. These terms are defined below:

Reservoir rock is a rock capable of containing oil and gas and yielding them during production. The reservoir rock is characterized by: rock type; permeability type (intergranular, fracture, and/or combination of the two); the total, intercommunicating, and effective porosity; specific surface area; wettability of rock (oil-wet versus water-wet); fracture type (width, etc.); and fracture distribution.

Reservoir is a natural subsurface container for oil, gas, and water. Its existence is predicated on the relationships between the reservoir rock and associated poorly permeable rocks. Reservoir is characterized by reservoir-rock type, relationship with impermeable rocks, reservoir capacity, its hydrodynamic conditions, reservoir energy, and structure.

Trap is part of the subsurface reservoir where an oil or gas accumulation can form and be preserved. Its parameters include the reservoir type, reservoir-rock type, conditions of its formation, structure, and capacity. In a special case where the reservoir is lithologically limited from all directions, its parameters may coincide with those of the trap (i.e., the entire reservoir is represented by a single trap).

The following features are used in describing a reservoir: (1) type of the reservoir rock comprising the reservoir; (2) relationship between the reservoir and the surrounding impermeable rocks; (3) reservoir capacity; and (4) depositional environment. In terms of the relationship between the reservoir and its surrounding impermeable rocks, Brod (1957) proposed to identify three major types of the reservoirs: bedded, massive, and lithologically limited in all directions. A similar classification, with characterization of the reservoir energy, was proposed by Eremenko (1941, Table 2.1).

Bedded reservoir is a reservoir that is restricted at its top and base by low-permeable rocks. The reservoir rock thickness in such a reservoir is more or less

TABLE 2.1

Classification of reservoirs

Reservoir type	Stratigraphic position	Direction of oil and gas flow	Possible maximum energy accumulated in oil and gas
Bedded	Consistent with stratigraphy	Along the bedding	Insignificant
Bedded, fault blocks (differentiated)	Consistent with stratigraphy	Restricted but possible in any direction	Much greater than in the bedded; may be even major
Massive	Inconsistent with stratigraphy	Vertical	Significant, rarely insignificant
Lithologically limited from all directions	Consistent with stratigraphy	Locally restricted	Major

constant over significant areas. Still, a substantial thickness change can occur locally or at the edge of the reservoir development, which may result in a pinch-out of the reservoir rock. The reservoir rocks in bedded reservoirs are usually lithologically continuous, but may have a more complex nature. A bedded reservoir may have a single hydrodynamic system.

Reservoir energy in bedded reservoirs is distributed in accordance with the hydrostatic or hydrodynamic environment of the artesian basins. However, reservoirs with that kind of energy distribution are typical only for the uppermost portion of the sediment cover. As a result of subsidence and sediment compaction and various secondary geochemical processes, reservoirs may be separated into diverse portions as a consequence of previously described phenomena.

Leaving aside changes in the sediment composition, drastic changes occur in the major reservoir-rock properties (porosity and permeability). Even if prior to subsidence the reservoir rocks were reasonably uniform in terms of porosity and permeability, subsequent to subsidence non-uniformities appear between various portions of reservoir so that they may turn out to be totally separated from one another. An indication of such a change may be a change in a hydrodynamic drive from artesian to "elision" type and the appearance of abnormally high pressure. The beginning of the process involves (1) lateral fluid migration, and (2) gradual change in the reservoir energy. Potential energy of the accumulations relative to the total energy of the reservoir is small. As the sheet-type reservoir differentiates, lateral migration becomes increasingly more obstructed, with formation of numerous hydraulic fractures. Fluid migration from the reservoir to other favorable zones (if they are available) may become prevalent. An increase in the elastic potential energy is observed (Abnormally-High Formation Pressure, AHFP). Energy distribution becomes discrete. The difference in potential energy between the accumulations and the reservoir as a whole becomes smaller, and within some zones (blocks) they become identical.

Thus, it is reasonable to recognize a separate type, i.e., differentiated sheet-type reservoir, which under certain circumstances becomes a bedded reservoir.

Massive reservoir is a thick permeable sequence overlain at the top and restricted from the sides by low-permeable rocks. Its bottom may be at a depth that has not yet been penetrated by wells (e.g., Tengiz Field, Kazakhstan). Reservoir rocks comprising massive reservoirs may be homogeneous or heterogeneous. Homogeneous massive reservoir rocks may be carbonates and metamorphic or volcanic rocks. Their porosity and permeability is due to the presence of vugs and fractures. Porous and permeable zones in massive reservoir rocks are not stratigraphically related. Isolated high-porosity and high-permeability zones cutting through stratigraphic surfaces within a body of a massif are common.

Buried reefs are often assigned to this reservoir type. Among the best examples are the Ishimbay group of fields in Bashkortostan, Russia, and Rainbow Oilfield in Alberta, Canada. Usually, the thickness (height) of massive reservoirs is greater than the width. The length of possible vertical fluid migration is similar or greater than the lateral migration within the beds. The flanks of the reservoir and its contacts with the contemporaneous sediments are steep (thus, the biostromes should be classified as

the sheet-type (bedded) rather than the massive-type reservoirs). Inasmuch as the bioherms are very similar to reef buildups, they should be considered as massive reservoirs.

To form a trapping mechanism, beside the caprock, the massive reservoirs require isolating steep lateral limitations. As an example, numerous present-day coral reefs in the Indian Ocean do not form subsurface reservoirs not only because of the absence of caprock, but also due to the absence of lateral barriers (lateral isolation). Fresh water accumulating within such bodies floats on the surface of heavier seawater.

The hydrodynamic system of the massive reservoirs is poorly studied. It is possible that they communicate at depth with the bedded (sheet-type) reservoirs and are, in effect, just a variety of a sheet-type reservoir.

Reservoirs lithologically limited from all directions include all types of reservoirs where the liquid or gaseous hydrocarbons present from the time of formation of the reservoir are surrounded from all directions with practically impermeable rocks. Fluid movement within such reservoir is limited by its size. There is some superficial similarity between the massive reservoirs and the differentiated sheet-type reservoirs. The similarity is in the limitation (lithologic isolation). The difference is in the timing of the emergence of the latter. The massive reservoir is a result of depositional processes, whereas the differentiated sheet-type reservoir is a result of stresses during the basin subsidence. The former type is originally small (certainly, any bed is a large lens, but this approach is not used here). The latter type is a separate portion of a previous, possibly large hydrodynamic system. Prevalent elastic energy is typical for both, but the latter type of reservoirs has a greater stress level. The capacity of any type of reservoir is defined by its size and reservoir-rock properties. Energy of a reservoir is associated with its capacity, and the energy is what is important for the extraction of oil and gas (and associated water).

The identification of the above four reservoir types is tentative, because such well-rooted concepts as reservoir rock and caprock (fluid barrier) are also tentative. Even in the same state, the same rock may be a fluid barrier to one fluid and a reservoir rock to the other, depending on the physicochemical properties of fluids and rocks (especially, wettability), and on the subsurface temperature and pressure. For instance, a prominent projection of a massive reservoir may be just a complication of a regional sheet-type reservoir and be a part of the same hydrodynamic system. This phenomenon is especially common in carbonate sequences. It is possible to imagine a conversion of a sheet-type differentiated (block) reservoir into a massive reservoir if the caprock loses its sealing properties over a fault or flexure. The hydrocarbon accumulation may then occur underneath another, shallower caprock.

Chapter 3

TEMPERATURE AND PRESSURE IN THE SUBSURFACE

3.1. DEFORMATION OF ROCKS IN DEPTH

3.1.1. *Porosity and permeability versus depth of burial*

Porosity and permeability of the uncompactd rocks decreases, and density increases with depth. Compaction of the South Louisiana Tertiary sands (Fig. 3.1) is a classical example. Sediments experience the total pressure of the overburden (rocks plus fluids), p_t , upon burial. Terzaghi determined the overburden pressure (accounting for lateral compression) as follows:

$$p_t = \frac{1}{3} D \rho g \left[1 + \frac{2\delta}{(1-\delta)} \right] \quad (3.1)$$

where D = the depth, ρ = the density, g = the gravitational acceleration, and δ = the Poisson's ratio. If, to take lateral stress into account, water is taken as a bed model (its Poisson's ratio is 0.5), Eq. 3.1 is simplified to

$$p_t = D \rho g \quad (3.2)$$

This equation is most common in practical applications.

The rocks under overburden pressure tend to compact, whereas formation pressure (fluid pressure) resists such compaction. Thus, compaction occurs due to effective pressure (p_e), which is equal to the total overburden pressure (p_t) minus the fluid or pore pressure (p_p):

$$p_e = p_t - p_p \quad (3.3)$$

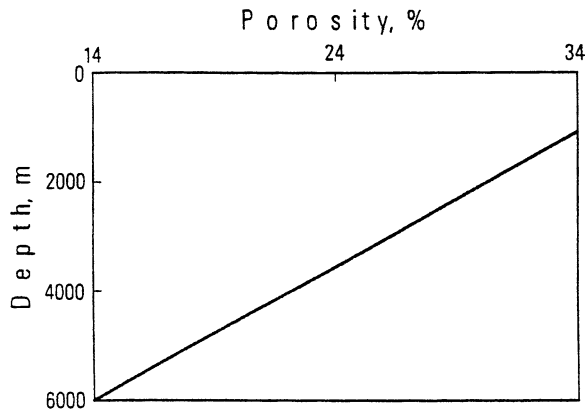

Fig. 3.1. South Louisiana, USA. Compaction of unconsolidated Tertiary sands with admixture of clay (after P. A. Allen and J. E. Allen, 1990).

The effective stress (p_e) determines the degree of compaction. Of importance here is the escape of water occupying the pore space (mainly upward). This process is determined by the permeability that changes with degree of lithification. Naturally, during burial different rocks compact differently. Fig. 3.2 shows compaction for different rock types. Sometimes, argillaceous rocks are more compactable than sandstones (also see Rieke and Chilingarian, 1974; Chilingarian and Wolf, 1975, 1976). Shale compaction is significantly affected by mineralogy. Fig. 3.3 shows changes occurring in montmorillonite, illite, and kaolinite clays upon compaction. Numerous experiments established that the most rapid water loss (hence compaction) occurs during the initial burial of sediments to a depth of 25–30 m. During this stage, the sediments lose 50–60% of their originally contained water. Consequently, the compaction rate significantly slows down. Most of the sediment compaction occurs at a depth of 600–800 m. After that, the process becomes almost imperceptible. Moreover, reservoir pressure increases due to the decrease in permeability and consequent decrease in the rate of water escape. Thus, under-compacted rocks form in some areas. Their major characteristic is the anomalously high pressure. The change in the clay's water content causes modifications in the clay texture. Mutual orientation of mineral microblocks and microaggregates changes. Also, the deflocculated clays are capable of plugging pores, pore throats, and canals, thereby significantly decreasing the reservoir–rock permeability.

Carbonates in the process of compaction also lose water, and rapidly change from the domain of plastic deformations into the domain of disruptive deformations. This results in microfracturing, and the rock that was a seal may become a reservoir. The carbonates with argillaceous and organic matter components usually have laminated

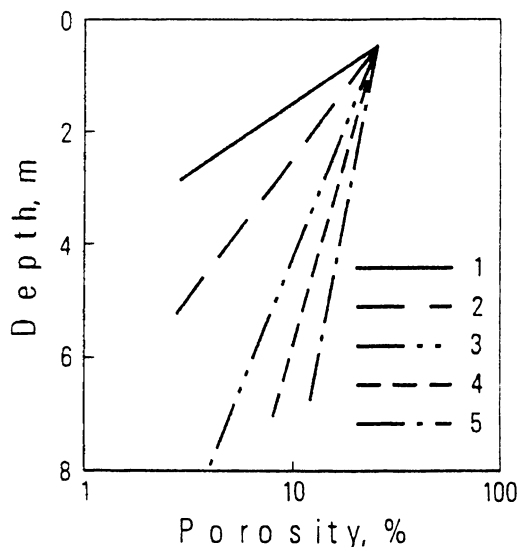

Fig. 3.2. Compaction of clays and sandstones (after Allen and Allen, 1990) 1 – Oklahoma (clay); 2 – Venezuela (clay); 3 – North Sea (clay); 4 – North Sea (sandstone); 5 – South Louisiana (sandstone).

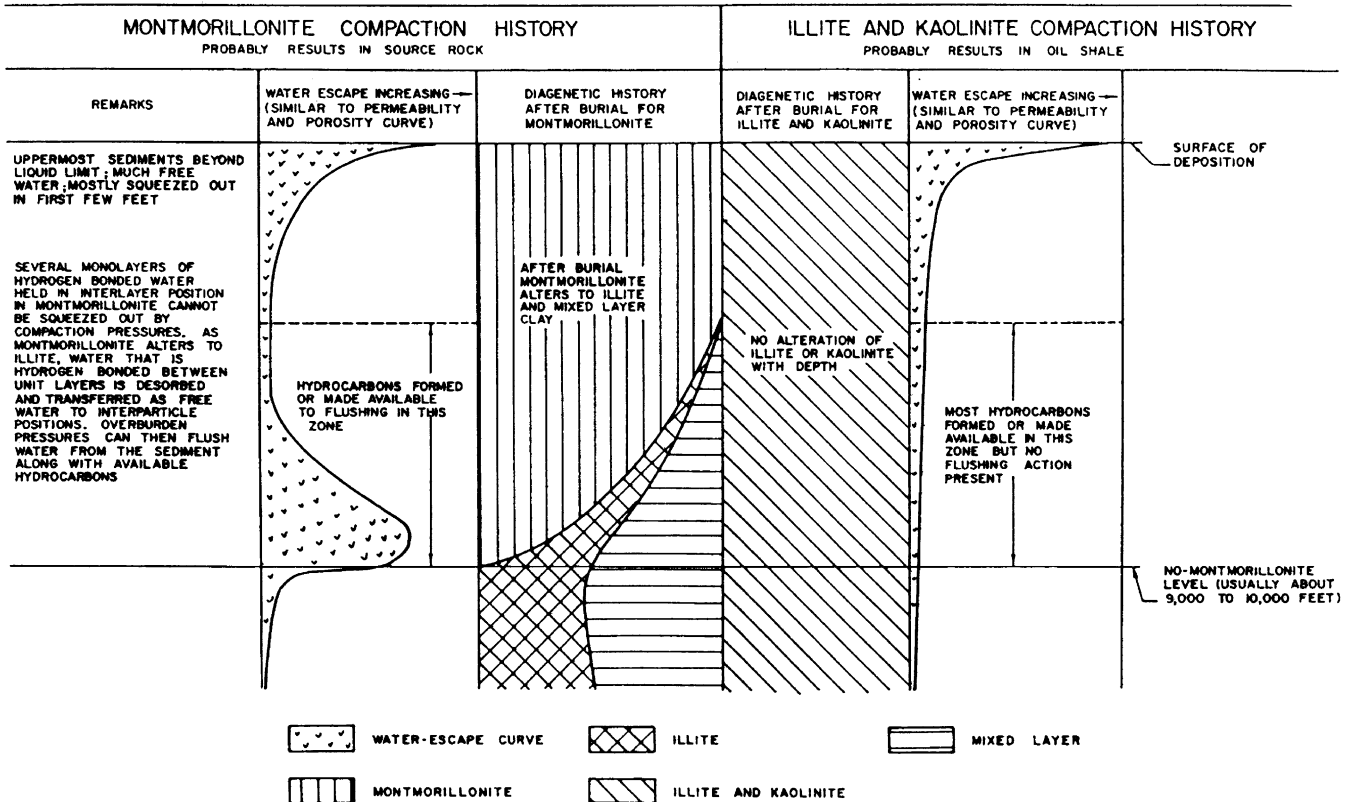

Fig. 3.3. Compaction history of various clays when deposited in marine environment and its probable relation to release of hydrocarbons from shales (after Powers, 1967, Fig.3, p. 1245).

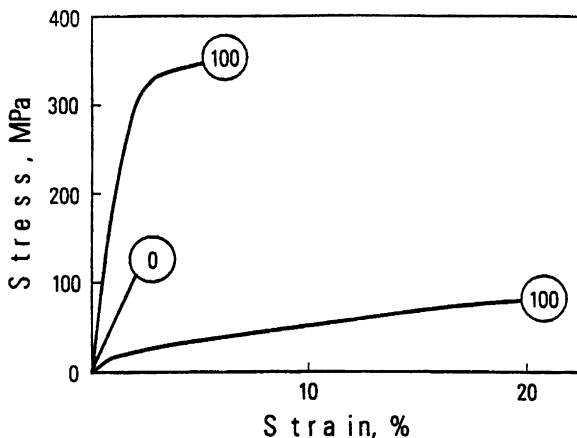

Fig. 3.4. Stress vs. strain in: (1) salt and (2) anhydrite (after Savchenko, 1977). Circled figures are confining (hydrostatic) pressures (MPa). 1 = upper curve, 2 = lower curve.

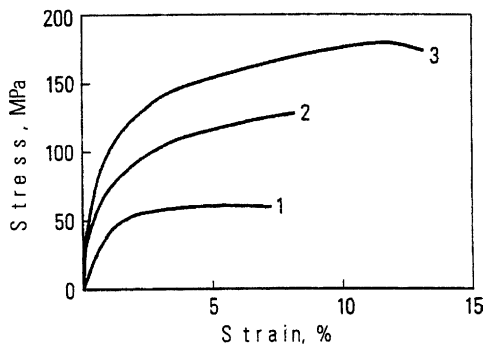

Fig. 3.5. Salt deformation diagram under non-uniform triaxial stress (after Pavlova, 1970). 1–3 — Effective stress: 1–25 MPa at 20°C; 2–50 MPa at 50°C; 3–100 MPa at 100°C.

texture. This on the one hand, improves their sealing capacity due to increased plasticity. On the other, non-uniform mineral composition and lamination result in the increased anisotropy and deterioration of their sealing capacity.

Experiments conducted by Savchenko and Bereto (1977) showed increased plasticity of evaporites under hydrostatic and, even, uniaxial pressure (Fig. 3.4). Much higher plasticity of salt compared to anhydrite was recorded. Evaporite plasticity increases as temperature increases. An example of the effect of temperature on salt plasticity is presented in Fig. 3.5.

3.1.2. Temperature

Temperature affects the physical (see Fig. 3.5) and physicochemical properties of rocks. It distorts the molecular bonds up to a total disruption, accelerates the

molecular motion, overcomes the temperature threshold of reactions, and increases the rate of chemical reactions. Thus, temperature affects the results of postdepositional processes in rocks during diagenesis and catagenesis.

With increasing temperature, different minerals (aggregates) comprising the rock expand differently according to their particular heat expansion coefficients. This phenomenon causes diverse consequences. The pore diameter and volume of pores should decrease causing a decrease in porosity and permeability. This, however, does not usually happen. T.T. Klubova (personal communication) believes that this is due to compaction of pore cement. Cement in the pores is supported by the rock particles and only slightly reacts to the net overburden pressure (effective stress). If cement does not completely fill the pores, it may have experienced only the reservoir (hydrostatic) pressure. When the temperature increases, cement compacts releasing the water. As a result, the pore volume increases exceeding its slight decrease caused by the temperature expansion of component minerals (heat expansion coefficients of rocks are very low).

On the other hand, heat expansion coefficients for liquids and gases are several times greater than those for rocks. The expanding fluids must either move into a different space (if available) or compress according to their compressibility, i.e., in fact to accumulate the elastic potential energy. This is how abnormally-high formation pressure (AHFP) occurs. Comparing AHFP with the excess pressure, one must distinguish the difference in their emergence and existence. AHFP emerges due to the accumulation of elastic potential energy and disappears when the stress is relieved (the energy dissipates). The emergence of the excess pressure is associated with the gravity division of fluids (water, oil, and gas) with different densities, and disappears when the density difference disappears (e.g., removal of one of the fluids and mutual dissolution at high temperature). This process occurs in the formation in a non-uniform way because of lithological variability. As a result, energy non-uniformity (difference in energy potentials) arises. One should recall that porosity and permeability change upon formation of fractures (Fig. 2.4). Porosity and permeability drastically decrease within the plastic deformation zone, and the rock becomes non-uniform energy-wise. The difference of energy potential, which is the major cause of fluid flow, causes additional stresses in the rocks. Thus, some changes in the texture of subsurface rocks is possible. Energy-wise, the rock particles will attempt to occupy a more favorable position in the new energy environment. Changes in the orientation of mineral aggregates in the rock will affect its magnetic properties.

Klubova (1984) conducted experiments on bentonite samples under different confining pressures. Natural moisture content of the samples was 12.5%. The original sample was subjected to a confining stress of 50 MPa at 20°C. The particles in the compacted sample became flatter and lost their original texture. The changes were even more pronounced in the sample compacted at 200 MPa. There was a further microblock separation and development of a more orderly texture. Klubova found that changes in the texture and an increase in zones of weakness in clays studied were affected more by the changes in temperature rather than changes in pressure.

Formation of AHFP lowers the effective pressure and results in the emergence of undercompacted rock zones. AHFP is non-uniformly and discretely distributed in rocks. That is why mapping of AHFP using uniform interpolation (and even more so, extrapolation) is not recommended.

It may be stated that

$$V_{\text{AHFP}} = V_{\text{elast}} - V_{\text{relax}} \quad (3.4)$$

where V_{AHFP} = the rate of formation (or destruction) of AHFP, V_{elast} = the rate of formation of elastic stresses and V_{relax} = the rate of stress relaxation.

This equation clearly shows all conditions for the formation or destruction of AHFP. It can only exist while the conditions for the formation of elastic stresses are present, and the rate of the formation (accumulation) of elastic energy is greater than the relaxation rate. A horizontal stress of 10 MPa at a depth of 1000 m will dissipate after 1 million years only due to diffusion (at a very low diffusion rate of 10^{-7}) (V.A. Sokolov and V.F. Lipetskiy, personal communication).

If stress in the rock matrix exceeds the plastic limit, the rock begins to fracture. As mentioned before, despite an insignificant decompaction (the fracture porosity is low), the permeability will drastically increase. In her compaction experiments using hydrostatic compaction apparatus, N.N. Pavlova (personal communication) found only 10–12% decompaction and increase in permeability.

Stress relaxation in rock matrix occurs through fracturing whereas reservoir pressure dissipation is due to the emigration of fluids through the fractures (and diffusion, but more slowly). The role of the fluids per se in the formation of fractures also should not be forgotten. Of particular significance here is water, which is a medium with the lowest compressibility. As a result, a very slight increase in the amount of water within the same pore volume results in a significant increase in pressure. The low compressibility of water makes it play a very important role in the formation of hydraulic fractures.

It was long and erroneously believed that a high pressure is necessary for hydraulic fracturing (overburden pressure plus additional pressure to overcome the rock strength³). This would be correct if the rocks had rigid, non-deformable matrix. The information derived from the practical applications of hydraulic fracturing (tens of thousands) indicates that hydraulic fracturing may be achieved at just 0.5–0.75 of the overburden pressure. The reason is that the rocks compress under the effective pressure. Rocks compact as a result of (1) decrease in the volume of water-filled pores, (2) temperature increase, and (3) relative increase in the volume of water due to its slow escape (low permeability). As a result, reservoir pressure significantly increases, causing hydraulic fracturing. The orientation of fractures is determined by zones of weakness in rocks (most often, bedding planes) and by the spatial position of a zone with the minimum (hydrostatic) reservoir pressure. Most commonly, fracturing occurs in the overlying or underlying reservoir rocks. The emerging difference in the reservoir pressure between the shales and reservoir rocks may be, as Buryakovskiy et al. (1990, p. 187) pointed out, an additional reservoir energy source

³Young's modulus for sedimentary rocks is in the range of $3-9 \times 10^{-14}$ g/cm².

for the field development (compaction drive). Transitional zones may form at the boundary, involving additional compaction in the reservoir rocks and under-compaction in the caprocks.

Rocks are quite heterogeneous and are in an unstable state in the subsurface. They are further destabilized because of non-uniform temperature distribution. Even on considering formation temperature as resulting from the heat flow, and even if the heat flow in the area is constant, the temperature of rocks will differ in different parts of the area. Heat flow is related to the temperature drop as follows:

$$q_l = \lambda \frac{dT}{dD} \tag{3.5}$$

where q_l = the conductive heat flow (MW/m^2), λ = the heat conductivity ($W/m^\circ C$), dT and dD = the temperature and depth differences ($^\circ C$ and m , respectively).

Heat conductivity depends not only on the properties of rocks, but also on their oil- or water-saturation, temperature, and pressure. As an example, the heat conductivity of dry rocks in Belorussia was as follows: clays — $1.02\text{--}1.56 W/m^\circ C$; sandstones — $1.34\text{--}2.12 W/m^\circ C$; limestones — $1.67\text{--}3.44 W/m^\circ C$ (Sergiyenko, 1984). Consequently, the temperature of rocks also changes depending on the properties of minerals composing the rock and on the water and oil saturations, with all other variables being equal.

The above discussion shows that temperature affects the sealing properties of rocks. Table 3.1 shows changes for the most reliable caprocks (Dobrynin and Kuznetsov, 1993, p. 106). As the table indicates, the necessary caprock thickness over the oil accumulations at the given temperatures is always higher than over the gas accumulations. This is mainly due to different interfacial tensions at the oil/water and gas/water contacts. Some improvement in sealing capacity at $60^\circ C$ as compared to $40^\circ C$ is due to a decrease in pore diameter and, consequently, to a lower permeability.

Interfacial tension also depends on temperature:

$$\delta = \delta_0[1 - \omega(T - T_0)] \tag{3.6}$$

where ω is the temperature expansion coefficient (0.002 for the water) and $(T - T_0)$ is the temperature difference ($^\circ C$).

TABLE 3.1

Type of $\Delta h_{\text{reservoir}} = f(\Delta h_{\text{caprock}})$ relationship for most reliable argillaceous caprocks of gas and oil accumulations

T ($^\circ C$)	Accumulation	Equation
40	Gas	$\Delta h_{\text{reservoir}} = 4\Delta h_{\text{caprock}}$
	Oil	$\Delta h_{\text{reservoir}} = 17\Delta h_{\text{caprock}}$
60	Gas	$\Delta h_{\text{reservoir}} = 2\Delta h_{\text{caprock}}$
	Oil	$\Delta h_{\text{reservoir}} = 7\Delta h_{\text{caprock}}$

$\Delta h_{\text{reservoir}}$ = reservoir thickness; $\Delta h_{\text{caprock}}$ = caprock thickness.

Changes in temperature strongly affect such rock property as sorption, which decreases with increasing temperature.

Certain zoning in porosity and permeability distribution is observed in the Earth's crust. According to Eremenko et al. (1986), the following vertical zones may be identified for the platforms:

- I. Karst zone
- II. Calcite cementation zone
- III. Decompaction zone
- IV. Gravitational compaction and silica/silicate generation/regeneration zone.

Of greater interest is Zone III, because it contains major oil reserves of the world and is present in all sedimentary basins.

Fig. 3.6 shows the distribution of the optimum reservoir-rock properties and oil accumulations in the geologic section. This distribution was presented by Maksimov and Minskiy in 1972, but is still valid today. Despite some oil and gas discoveries at great depths, the bulk of the reserves is concentrated between the depths of 1 and 3.0–3.5 km.

The top of Zone III is located at a depth of 1.8 km (average of 32 regions of the world). Reservoir rocks in that zone are formed mostly due to calcite dissolution, and the newly-formed fractures are not cemented with calcite. Another favorable factor is the montmorillonite-to-illite transformation, which is quite intense in Zone III. Calcite dissolution is due to the decrease in pH of water and the simultaneous aggressive action of CO_2 , concentration of which in formation water increases.

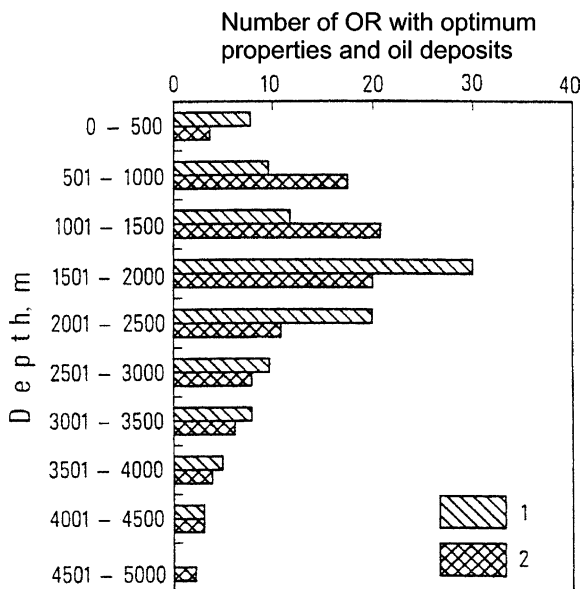

Fig. 3.6. Depth distribution of areas of (1) reservoir rocks (OR) and (2) oil accumulations (OA) with optimum properties (after Maksimov and Minskiy, 1972).

A lower pressure, as compared with the surrounding shales, forms within the upper portion of the Zone III during subsidence. As mentioned before, the montmorillonite-to-illite transformation is accompanied by the release of water and shale loosening, after which shales compact further. Released water (that had been previously chemically bonded) is chemically aggressive and dissolves various salts as well as hydrocarbons in the surrounding rocks.

Pressure inversion occurs in Zone IV down the section. Reservoir pressure exceeds the pore pressure in shales. Silicified reservoir rocks become fluid barriers, whereas compacted argillaceous rocks experience fracturing and become reservoir rocks.

The described phenomena that occur at elevated subsurface pressures and temperatures is significantly complicated and intensified because of some other energy sources. These sources include tectonic stresses, seismic activity, changes in the energy and magnetic fields, and exothermal reactions of mechanochemical nature. Minskiy (1975, p. 128) pointed out that “Domains where reservoir rocks have optimal properties are most favorable for the phase transitions of hydrocarbons due to the decline of pore pressure in reservoir rocks. Salt concentration in formation water changes, which, . . . , facilitates the release of hydrocarbons as a free phase and the concentration of its emulsions.”

Obviously such processes vary in different regions. Fig. 3.7 illustrates this process for the Lower Cretaceous Travis Peak Formation, Texas (Dutton and Diggs, 1992). As a result, porosity decreased from 40% to a few percent and permeability decreased from over 100 to 0.0001 mD at a depth of 3500 m. At the same time, cement content increased from about 20% at a depth of 2000 m to 35% at 3500 m.

Most of the chemical reactions occurring during postdepositional processes in water are substantially affected by the hydrogen ion concentration (pH) and oxidation/reduction potential (Eh), which are related as follows:

$$Eh = \Delta Z/nF - \gamma(pH) \tag{3.7}$$

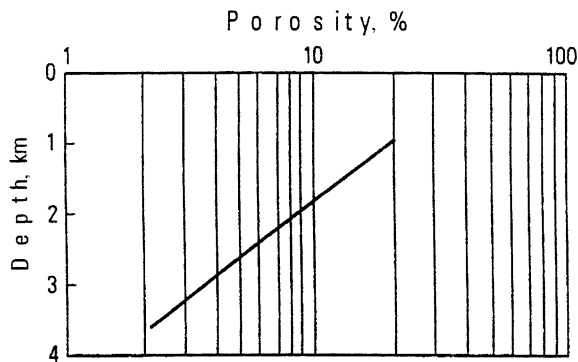

Fig. 3.7. Travis Peak Sandstone, East Texas, USA. Relationship between porosity and depth of burial (after Dutton and Diggs, 1992). $\gamma = 0.76$; $n = 89$.

where ΔZ = the free energy of reactions; n = the number of electrons taking part in the reaction; F = the Faraday constant (96,520 C/g-eq.); and y = the constant for a given reaction.

The above equation shows that as alkalinity of the environment declines, a less reducing environment is needed for the reduction⁴ of the same components. It appears that a strongly alkaline environment is not necessary and may even be detrimental for the transformation of organic matter into hydrocarbons. Minerals participating in the processes have significantly different pH and Eh stability limits. For instance, at a stage of syngeneses and early diagenesis ($p < 10$ MPa, $T < 60$ – 70°C), the pH stability limits for various minerals are (after Minskiy, 1975, pp. 147–150):

anhydrite	8.4	calcite	7.8–8.7
halite	7.8	kaolinite	3.5–5.6
hematite	7.4	quartz	7.8
illite	7.8	montmorillonite	7.8–8.2
clay	8.7	pyrite	5.0–6.2
dolomite	8.4	siderite	6.2–7.2

Besides the pressure and temperature, postdepositional processes are affected by a number of factors, which include the appearance and redistribution of the cement, changes in the structural (textural) orientation of rock-forming minerals, and dissolution of minerals unstable in a given environment. The intensity of these processes is affected not only by the aforementioned factors, but also by the permeability at a given time. As an example, Fig. 3.8 shows relationship between the permeability of quartz sands and clay mineral content (Klubova, 1984, p. 151). The most drastic changes in the permeability occur when the clay content increases within just a few percentage points. Further increase in clay content between 10% and 80% does not significantly affect the sand's permeability.

As indicated previously, rock properties are significantly affected by the formation of authigenic minerals. Newly-formed authigenic minerals reduce the porosity and permeability due to fineness of grains and swelling of some minerals.

A significant role in the postdepositional alterations of carbonate rocks belongs to recrystallization and dissolution. These processes usually result in increased porosity. In some cases, however, the emerging pores are easily filled-up with secondary (authigenic) minerals, mostly calcite and dolomite. In 1954, Chilingar and Terry have shown that dolomitization of limestones creates additional porosity (up to the theoretical value of 12.1%) (also see Chilingarian et al., 1992, 1996). Some researchers (Minskiy, 1975, p. 27) question this because dolomitization is occurring along the grain contacts. Actual field data, however, supports the findings of Chilingar and Terry (1954).

Reservoir–rock properties of carbonates are substantially affected by the presence of organic matter, which sometimes gives rise to laminated texture. Organic matter

⁴Oxidation is a reaction in which the electrons are lost, whereas reduction is a reaction where electrons are gained.

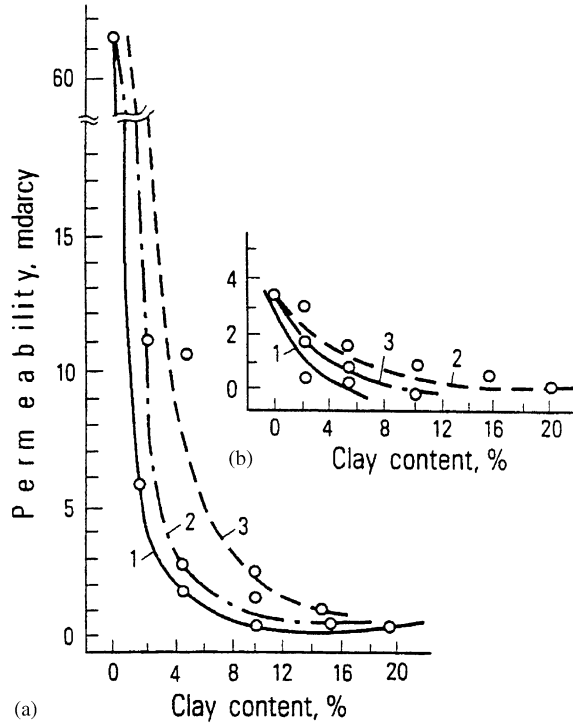

Fig. 3.8. Relationship between the clay content and permeability of quartz sand fractions: (a) 0.35–0.50 mm and (b) 0.08–0.12 mm (after Tsvetkova, modified by Klubova, 1984). Clays: 1 – montmorillonite; 2 – polymictic; 3 – kaolinite.

also changes the chemistry of the ongoing processes because of (1) changing pH, (2) reactions with CO_2 forming as a result of organic matter transformations, (3) direct effect on the temperature (as a result of endothermic and exothermic processes), and (4) pressure changes due to increase in volume after the formation of new compounds.

3.1.3. Paleotemperature

The study of evolution of a sedimentary basin is incomplete without a sufficient knowledge of its paleotemperature regime. The probability of occurrence of some mineral resources in basins is to a great extent controlled by the temperature, which determines feasibility and direction of various chemical reactions. Usually, the products of chemical reactions are what we are looking for, i.e., mineral resources.

The preservation and destruction of migrating mineral resources (such as oil and gas) also depend to a great extent on the temperature evolution of a basin. Thermodynamic boundaries for some reactions or formation of some compounds,

or even regularity in changes of some physical properties (such as, color, reflectance, etc.) may be used as indicators of paleotemperatures.

Most common methods of determining the paleotemperature are the vitrinite reflectance and, sometimes, the spore and pollen coloration. There are techniques of determining the paleotemperatures from the crystallization temperature of authigenic minerals (also gas and liquid inclusions), from the isotope composition of oxygen and carbon in calcite, etc.

Currently used techniques are imperfect. Even the best developed and most commonly used vitrinite reflection technique was widely criticized over the recent decades. Price (1985) believes that the vitrinite crystalline structure is imperfect, because the hydrogen content in vitrinite changes causing variations in R_o . Dow (1977) showed that R_o changes not only with depth, but also with the age of sediments (Fig. 3.9). The methodology developed by Ammosov et al. (1987) is successfully applied and further updated. Saxby (1982) studied the chemistry of organic matter alterations and the changes in the vitrinite reflectance R_o .

Some investigators relate the R_o values directly to the depth of burial. This makes the problem much more difficult due to variability of geothermal gradient. For instance, the R_o vs. depth correlation (Fig. 3.10) becomes clear only together with the temperature vs. depth correlation (Wescott and Hood, 1994).

To summarize, changes of the organic and mineral components in the course of lithogenesis of petroleum sequences depend on the paleodepth, thickness and the duration of exposure to high temperature. The main feature of such changes is in their variability that result in the generation of different energy potentials in the various portions of the sequence and in its total state of energy intensity.

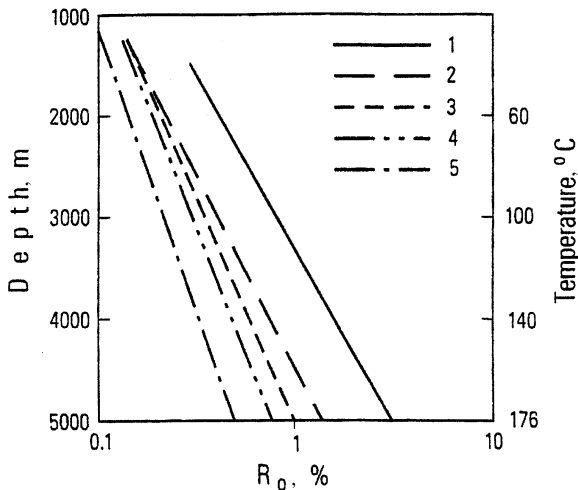

Fig. 3.9. Vitrinite reflectance R_o vs. depth of burial, temperature, and geological age (after Dow, 1977). 1 = Chalk, 2 = Eocene, 3 = Oligocene, 4 = Miocene, 5 = Pleistocene.

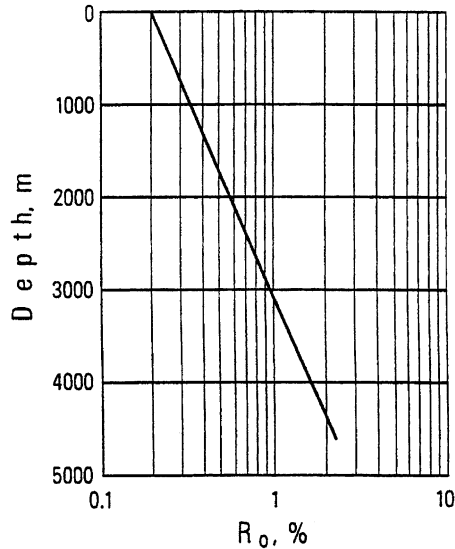

Fig. 3.10. Vitrinite reflectance R_o vs. depth of burial in cores from a well in Texas (after Wescott and Hood, 1994).

3.2. ABNORMALLY-HIGH FORMATION PRESSURE

Abnormally-high formation (pore) pressure (AHFP) or overpressure is encountered worldwide in sand–shale or massive carbonate–evaporate sequences from shallow to great depths, in formations as old as Cambrian. Many problems related to origin and distribution of abnormal formation pressures were discussed by Dickinson (1953), Foster and Whalen (1966), Fertl (1976), Fertl and Chilingarian (1977), Dobrynin and Serebryakov (1978, 1989), Magara (1982), Buryakovsky et al. (1986b), Aleksandrov (1987), Buryakovsky et al. (2001), Chilingar et al. (2002), etc. The system of abnormally high formation pressure is presented in Fig. 3.11.

The ability to predict, locate, and evaluate overpressured formations is critical in drilling and completion operations, and in developing exploration and reservoir engineering concepts. Although improved during the last decade, the overpressure prediction methods are still far from being perfect. This has been identified as one of the challenges of geoscience technologies. For predicting AHFP, the following geophysical and drilling data are used:

3.2.1. Well-logging data

Well-logging techniques in studying formation pressures were discussed in detail by Buryakovsky et al. (1986b). Overpressure can be calculated from the resistivity logs. This method involves the study of shales and sands separately, and then correcting the shale resistivity for the formation temperature. The temperature correction is based on an empirical relationship derived for the region or area under

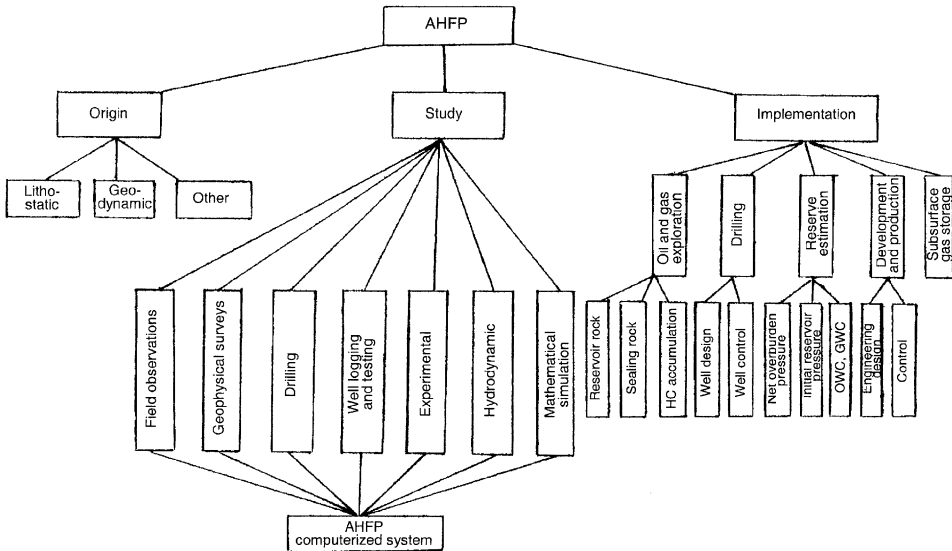

Fig. 3.11. System of abnormally-high formation pressure (AHFP).

study. Once the temperature correction is applied, a normal compaction trend for shales is established for the well. The overpressured zones are identified by the deviation from the normal trend of pore-pressure gradient. The same method can be applied for determining the overpressure from sonic or neutron logs (see Chilingar et al., 2002).

If different wells exhibit different and distinct pressure gradient patterns, each well represents a separate pressure compartment. Layering and variations in the overpressure are sometimes due to the fact that pressure builds up in the shales and then bleeds off into the associated permeable sands and sandstones. An excellent prediction criteria and sensitivity analysis of formation pressure in sealed layers were proposed by Dobrynin and Serebryakov (1978, 1989) and Khilyuk et al. (1994).

3.2.2. Seismic data

Pore pressure and fracturing pressure can be determined using the seismic velocity and empirical relationships among seismic velocity, rock density, and Poisson's ratio. A typical methodology can be summarized as follows:

- (1) the stacking velocity from seismic data is calibrated using well velocities;
- (2) the normal pressure gradient curve is calculated for the sonic velocity curves;
- (3) the pore pressure is determined from the seismic velocity data using the normal-trend curve; thus, the pore pressure distribution in a section is established; and
- (4) the fracture-pressure gradient is determined from the (a) pore-pressure gradient, (b) interval velocities, and (c) empirical relationships among velocity, density, and Poisson's ratio.

3.2.3. *Drilling data*

Overpressure can be estimated using drilling data. To predict pressure from the drilling data, a fuzzy logic has been used by Aminzadeh et al. (1994). This method was first applied to the data from South Caspian Basin. Drilling parameters such as the bit weight, rate of penetration, and changes in the rate of penetration were used for this purpose. The information obtained from pressure prediction is used to choose the required drilling mud density. Also, lithology can be predicted from the pressure data (Aminzadeh et al., 1994; Dunan, 1996; Lee, 2000).

Many factors contribute to the magnitude of abnormal formation pressure. These include:

- Compaction of the rocks with a change in porosity.
- Mass transfer fluxes.
- Temperature changes.
- Diagenetic and catagenetic transformations.
- Chemistry of interstitial fluids.
- Lithology and mineralogy.
- Sand/shale ratio.
- Distribution of porosity and permeability in associated sands and shales.

The abnormally-high formation pressures in the argillaceous sequences may substantially affect the geological processes at depth. They evidently have played an important role in folding, clay diapirism, mud volcanism, earthquakes, and diagenesis–catagenesis. The models of these phenomena are described by the Coulomb's law and by the rheological models of various theoretical bodies. According to the Coulomb's law, resistance to shearing in shales is the first power function of normal compressive stress. As abnormal pore pressure in shales increases, the intergranular stress (effective stress) decreases, down to very low values under certain conditions. Resistance to shearing, determined by friction, decreases correspondingly. This leads to an intergranular sliding and facilitates, to a considerable extent, the development of shearing. In such instances, plastic argillaceous sequences become quite mobile at high pore pressure in shale and are displaced. Depending on the subsurface environment and duration, this process may lead to the development of folds, diapirs, mud volcanoes, or earthquakes. In the South Caspian Basin and onshore of Azerbaijan, such geologic setup is quite typical of thick Paleogene to Miocene argillaceous sequences with extremely high, quasigeostatic values of AHFP, with shale pore pressure gradients of 0.020–0.023 MPa/m (Buryakovsky et al., 1986, 1995, 2001).

Development of abnormal pore pressures in shales of the South Caspian Basin and onshore of Azerbaijan has been experimentally demonstrated by elastic compression of hermetically sealed cores of Cenozoic shales. Fig. 3.12 shows that the pore pressure (p_p) in the core rises with increasing external confining pressure (total overburden load, σ) and then decreases as the confining pressure decreases, but always remaining higher than in the case of increasing load, evidently as a result of residual (irreversible) deformation of the rock (see Rieke and Chilingarian, 1974).

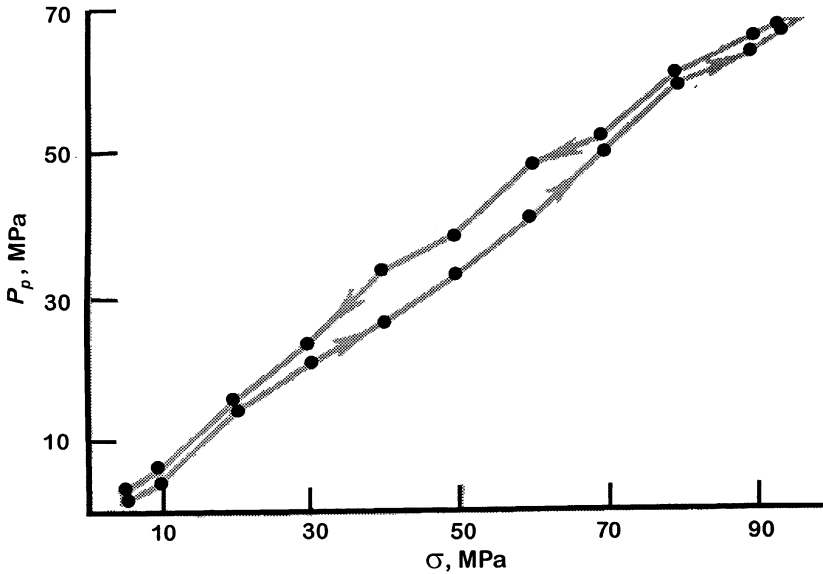

Fig. 3.12. Experimentally determined relationship between the pore pressure (p_p) and the total stress (σ) for an argillaceous rock core (after Buryakovskiy et al., 1995, Fig. 6, p. 207). Arrows show increasing and decreasing total overburden stress (confining pressure).

In studying the abnormally-high formation pressure, of special interest are the young sedimentary basins, which are characterized by the presence of thick, rapidly accumulated sand/shale sequences. A vivid example is the South Caspian Basin, which is distinguished by a diverse and rather unique association of the following features:

- an exceptionally high rate of sedimentation (up to 1.3 km/my) (my = million years);
- a very thick (up to 25 km) sedimentary column; thickness of the Quaternary – Pliocene sand–silt–shale sediments up to 10 km;
- argillaceous rocks make up 50–95% of the section and play a key role in determining the mineralogic, lithologic, geochemical, and thermodynamic characteristics of the basin;
- abnormally-high pore pressure in shales (average factor of abnormality⁵ up to $K_a = 1.8$);
- low heat flow and low formation temperature (at depths around 6 km, the temperature is approximately 105–110°C);
- an inverted character of the water chemistry and total salinity profile (the chemistry of water changes with depth from calcium chloride and magnesium chloride to sodium bicarbonate type, and water salinity decreases with depth);
- wide development of mud volcanism.

⁵Abnormality factor $K_a = p_a/p_n$, where p_a is abnormally-high formation pressure and p_n is the normal hydrostatic pressure.

The abnormally-high formation (pore) pressures (AHFP) in reservoirs are known to be caused by several diverse factors. It appears, however, that the most probable mechanism of AHFP development in regions with thick sedimentary rocks (sand–shale sequence) is a rapid sedimentation and gravitational compaction. This leads to significant underconsolidation (undercompaction) of rocks and to a development of AHFP. Abnormal pressures in reservoir rocks are often caused by the influx of water from the overpressured shales. Pressures in sandstones and shales approach each other only in moderately thick beds. The reservoirs of regional extent have a better pressure distribution, than those in shales; consequently, their pore pressure usually is lower than that in the enclosing shales (Fig. 3.13).

In the South Caspian Basin, the drilled Pliocene siliciclastic section is 6.5 km thick, with unevenly distributed AHFP, both vertically and laterally. Presence and magnitude of AHFP are determined by studying the lithofacies of the oil- and gas-bearing rocks, structure of the uplifts, sand/shale thickness ratio, influx of water from the shales into sands, integrity of caprocks, distribution of faults and fractured zones, etc.

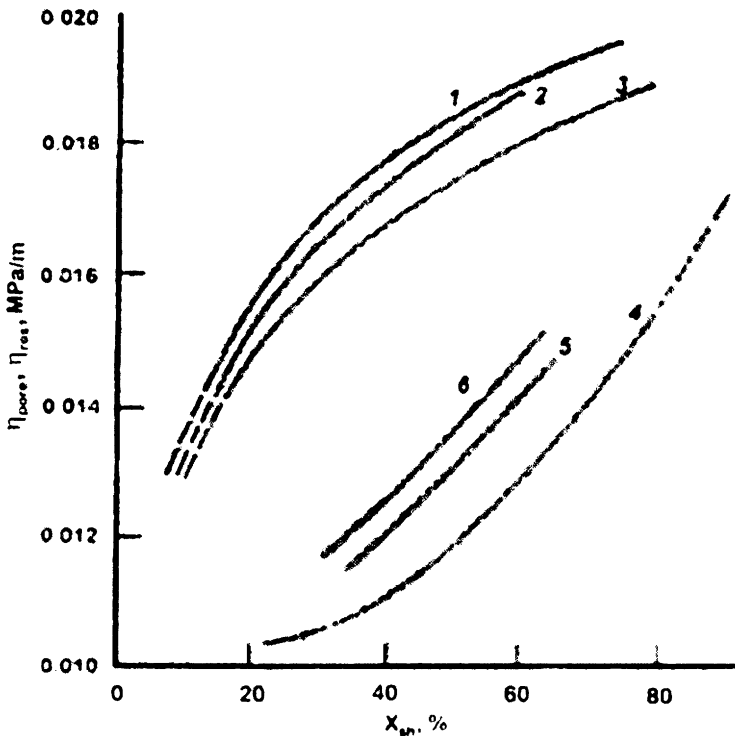

Fig. 3.13. Relationship between the pore-pressure gradient and relative clay content (after Buryakovskiy et al., 1995, Fig. 5, p. 207). 1-3 — Argillaceous rocks from three different areas; 4 — aquifers, 5 — oil-bearing sandstones and siltstones, 6 — gas-bearing sandstones and siltstones.

An important regional feature of AHFP is a very high porosity of argillaceous rocks (undercompaction), much higher than those at similar depths in the other areas of the world (Buryakovsky et al., 1982; Dzhevanshir et al., 1986). Porosity of Pliocene shales in the South Caspian Basin at depths of 4.0–5.5 km is several times higher than in the consolidated shales present in other regions at the same depth. Such a difference is the effect of young geologic age, relative contents of clay and sand, formation temperature, and other factors. The abnormally-high porosity of shales is primarily the result of slower rate of compaction compared to the subsidence rate, due to the slow pore water removal from the compacting argillaceous rocks during rapid sedimentation.

It should be noted that AHFP in argillaceous sequences is often attributed to the montmorillonite dehydration as it is altered to illite (hydromica). As shown in Table 3.2, practically unaltered montmorillonite is present in the deposits of the South Caspian Basin at depths down to 6 km, i.e., throughout the entire drilled section. That indicates a subordinate role of montmorillonite dehydration in the total process of AHFP development in the region.

Montmorillonite and illite–montmorillonite (mixed layered) minerals may be transformed to illite during the diagenesis and catagenesis, as described for almost all major sedimentation basins throughout the world. These changes in clay minerals during catagenesis are most probable (not simply possible, as in diagenesis), due to an increase in temperature and pressure as the sediments are buried. Consequently, during late catagenesis, the clay–mineral assemblage consists of two components (illite and chlorite), regardless of the initial composition. This is true in many parts of world.

On the other hand, virtually unaltered montmorillonite has been observed in Azerbaijan, at great depths and in large amounts (Kheirov, 1979). Kerimov explained the almost unaltered montmorillonite found at a depth of 6026 m in the Pliocene beds of the Baku Archipelago as due to specific sedimentation conditions,

TABLE 3.2

Clay–mineral composition in the Absheron Archipelago Rocks (average values are presented in the denominator)

Depth range (m)	Content of clay minerals (%)				
	Montmorillonite	Illite	Kaolinite	Chlorite	Mixed-layered
1000–2000	$\frac{10-45}{32}$	$\frac{35-65}{44}$	$\frac{15-20}{18}$	$\frac{5-10}{6}$	Traces
2000–3000	$\frac{35-70}{45}$	$\frac{20-40}{35}$	$\frac{0-15}{13}$	$\frac{0-10}{7}$	Traces
3000–4000	$\frac{15-50}{36}$	$\frac{30-60}{42}$	$\frac{5-20}{14}$	$\frac{5-15}{7}$	$\frac{0-5}{1}$
4000–5000	$\frac{15-70}{40}$	$\frac{10-60}{38}$	$\frac{0-20}{12}$	$\frac{0-10}{6}$	$\frac{0-30}{4}$
5000–6000	$\frac{5-65}{39}$	$\frac{20-65}{39}$	$\frac{0-30}{16}$	$\frac{0-15}{5}$	$\frac{0-15}{2}$
> 6000	$\frac{5-70}{36}$	$\frac{20-60}{38}$	$\frac{10-25}{16}$	$\frac{0-10}{4}$	$\frac{0-25}{7}$

the composition of the initially deposited clays, and the abnormally low temperatures, i.e., these sediments lie in the early diagenetic zone. In some cases, absence of potassium ion in the pore water of sediments could explain the absence of montmorillonite-to-illite transformation.

Of great importance is the study of (1) regularities in the distribution of clay minerals over the entire section, (2) identification of basic factors influencing the transformation of montmorillonite to illite, and (3) prediction of catagenetic changes at greater depths not yet reached by boreholes. It is not always possible to determine the origin of clay minerals, i.e., whether they are primary or secondary. For example, Milleau (1968, see Buryakovskiy et al., 1989) noted that the montmorillonite formed at the final stage of illite degradation does not differ from the primary montmorillonite, as evidenced by the X-ray analysis.

Photomicrographs of fresh broken surfaces of argillaceous rocks of the Productive Series of the Baku Archipelago (depths of 1400–5200 m) were taken with scanning electron microscope (SEM) (Buryakovskiy et al., 1986, 1988). The surfaces were examined in sections cut parallel, perpendicular, and oblique to the bedding. The mineral compositions of these rocks are generally the same throughout this depth range. The main clay minerals are illite and montmorillonite, with small amounts of kaolinite and chlorite. The rocks have a honeycomb-like texture, which is clearly seen in oblique sections.

The SEM results indicate that there are both “forward” and “reverse” clay–mineral transformations, which occur simultaneously as the rocks are buried. The cores from the depths of 1400–1800 m show only very slight changes in the clay minerals, although one can identify damaged sublayers (twisting) at the edges, as well as secondary pores and cracking in some illite grains. There are also microcavities formed by diagenetic processes. Cores from depths greater than 4000 m show greater evidence of transformation. Illite and montmorillonite predominate, with the montmorillonite being of both primary and secondary origin. The secondary montmorillonite occurs in the interstices between the illite grains, at their edges, and in cracks. The primary montmorillonite is disrupted or twisted at the edges and the secondary pores are present.

These Pliocene beds show degradation not only of the primary montmorillonite but also of the illite, which changes to montmorillonite. Probably, these transformations are largely responsible for the retention of the same illite-to-montmorillonite ratio at depth.

Transformation of clay minerals during catagenesis is a complex process, proceeding over a long period of geologic time under the influence of interrelated and interdependent factors. It is extremely difficult to determine the effect of various factors, i.e., to give a quantitative estimate of the intensity of influence of each one. The solution to this problem probably lies in future investigations. The effect of subsurface temperature and pressure and hydrochemical factors on the postsedimentary (diagenetic and catagenetic) alteration of these Pliocene clays should be studied using the data on chemical analyses of formation waters (e.g., availability of potassium ion), formation temperatures, and pore pressures determined from logs.

3.2.4. *Effect of pressure and temperature*

The abnormally low temperatures may be responsible for the absence of clear-cut clay–mineral transformation. Khitarov and Pugin (1966) and Magara (1982) have indicated that temperature is a major factor influencing montmorillonite degradation. Also of interest is the effect of illite degradation on the geothermal gradient. Inasmuch as hydration of clays is an exothermic reaction, there may be elevated gradients at depth ranges where the illite is transformed to montmorillonite, all other conditions being equal.

In the areas of South Caspian Basin, the average geothermal gradient is approximately 16°C/km, and the temperature at a depth of about 6 km does not exceed 110°C. A characteristic feature is that the geothermal gradient becomes lower at a depth of approximately 4 km (Table 3.3). Table 3.3 includes also the data on pore-pressure gradient in these areas.

The increased geothermal gradient at a depth of about of 4 km may be related to the illite-to-montmorillonite transformation, which releases heat. At a depth of about of 4 km, the transformation rate exceeds some limit, which causes hydration to predominate over dehydration. One should, therefore, consider the effects of temperature on diagenetic and catagenetic processes.

An increase in temperature may accelerate the process of montmorillonite transformation into non-swelling minerals (illite and chlorite). Consequently, sections with high geothermal gradient should be characterized by a small montmorillonite content. On the other hand, inasmuch as a temperature decrease retards the process of montmorillonite transformation, sections with low geothermal gradient should be characterized by a high montmorillonite content.

Fig. 3.14a shows the dependence of montmorillonite content on the geothermal gradient in shales of the South Caspian Basin. The highest montmorillonite contents are found in the shales of the Baku Archipelago and Lower Kura Depression, which are characterized by a low geothermal gradient (16°C/km). The Absheron Peninsula

TABLE 3.3

Variation of geothermal gradient and pore pressure gradient with depth (average values are presented in the denominator)

Depth range (m)	Geothermal gradient (°C/km)	Pore-pressure gradient (MPa/m)
1000–2000	$\frac{10-15}{12}$	$\frac{0.012-0.020}{0.016}$
2000–3000	$\frac{10-12}{11}$	$\frac{0.013-0.021}{0.017}$
3000–4000	$\frac{8-11}{10}$	$\frac{0.014-0.022}{0.018}$
4000–5000	$\frac{15-19}{17}$	$\frac{0.015-0.023}{0.019}$
5000–6000	$\frac{21-23}{22}$	$\frac{0.015-0.023}{0.019}$
> 6000	$\frac{15-25}{20}$	$\frac{0.016-0.024}{0.020}$

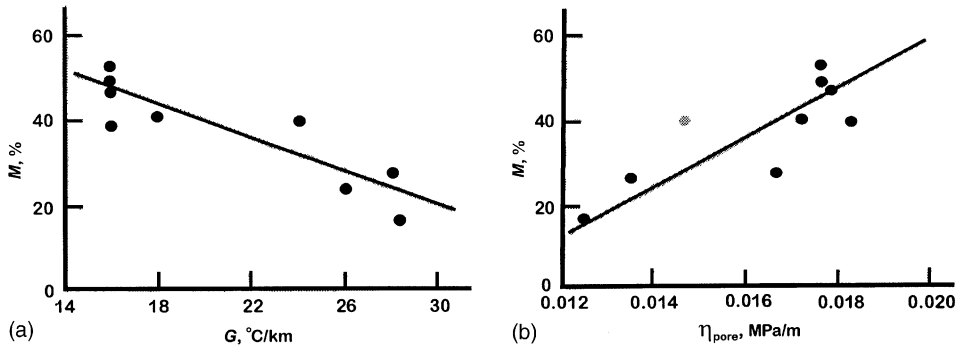

Fig. 3.14. Dependence of the montmorillonite content on the geothermal gradient (a) and on the pore-pressure gradient (b) in shales (after Buryakovskiy et al., 1995, Fig. 7, p. 211).

and the adjacent offshore areas, which have a higher geothermal gradient (24.0–28.5°C/km), are characterized by lower montmorillonite contents.

Low temperature apparently does not favor the transformation of montmorillonite to illite. Under otherwise equal conditions, this transformation increases with depth, which means that some additional factors must be influencing the transformation. One of these factors, discussed by Serebryakov et al. (1995), is the lack of potassium ion in interstitial water.

Inasmuch as the transformation of montmorillonite into illite proceeds with the removal of interlayer water from montmorillonite, conditions at which the desorbed water can enter the pore space without hindrance will be favorable for the development of this process. Factors opposing the withdrawal of interlayer water from clays, may lead to slowing down or cessation of the transformation of montmorillonite into illite or chlorite. The writers believe that such a factor is the abnormally high pore pressure. The fluid pressure gradients in shales at 1000–6000 m, which are based on more than 2000 determinations, range from 0.012 to 0.024 MPa/m, with a mean of 0.018 MPa/m (see Fig. 3.15 and Table 3.3).

The dependence of montmorillonite content on the pore-pressure gradient in shales is shown in Fig. 3.14b. There is a close correlation between these two parameters. In regions of the Baku Archipelago and Lower Kura Depression, characterized by intense development of AHFP (pore pressure gradients in shales of 0.018–0.019 MPa/m), the montmorillonite content in shales reaches an average of 53%. In regions with moderate development of AHFP (Absheron Archipelago and the South Absheron Offshore Zone), the montmorillonite content decreases to 17%.

There is no adequate discussion in the literature on the effect of pore pressure in shales on the clay–mineral diagenesis and catagenesis. Theoretically, the rising pressures reduce the dehydration rates. The production of illite in shales involves an increase in the volume of free water as a result of the release of bound water, which is denser than the free water. Factors opposing this increase in volume (such as high pore pressure in shales) will reduce the dehydration rate.

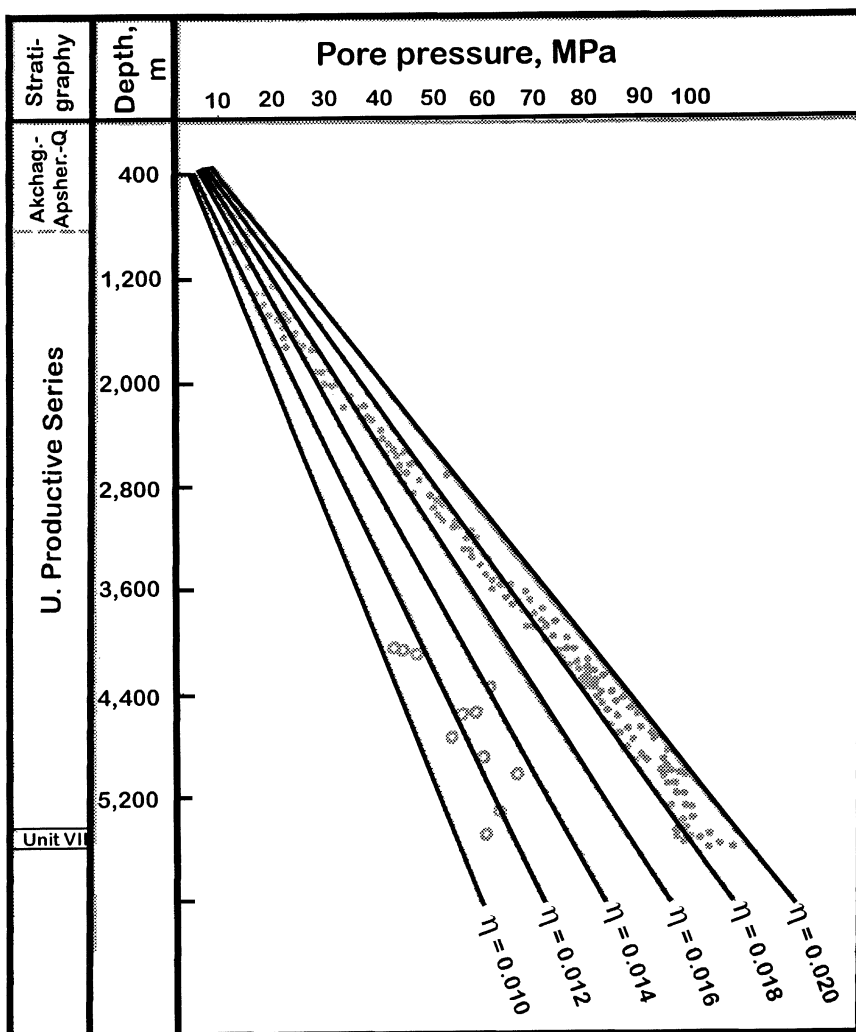

Fig. 3.15. Pore fluid pressure gradient (η) in shales (small circles, 1) and in reservoir rocks (large circles, 2) in the Baku Archipelago, South Caspian Basin (after Buryakovskiy et al., 1995, Fig. 2, p. 205).

On the other hand, AHFP can lead to transformation of illite to secondary montmorillonite by the absorption of water. At AHFP, the smaller particle size of clay minerals favors the transformation of illite, as shown by the relationship between the pore size (determined from SEM data) and depth (Table 3.2 and Fig. 3.16).

The writers propose the following scheme for the relationship between the clay-mineral transformation and the formation temperature and pressure.

In a basin where the subsidence rate is equal to the rate of accumulation of sediments, the depth at which diagenetic (and catagenetic) transformation (desorption of water) begins remains more or less the same and is largely determined

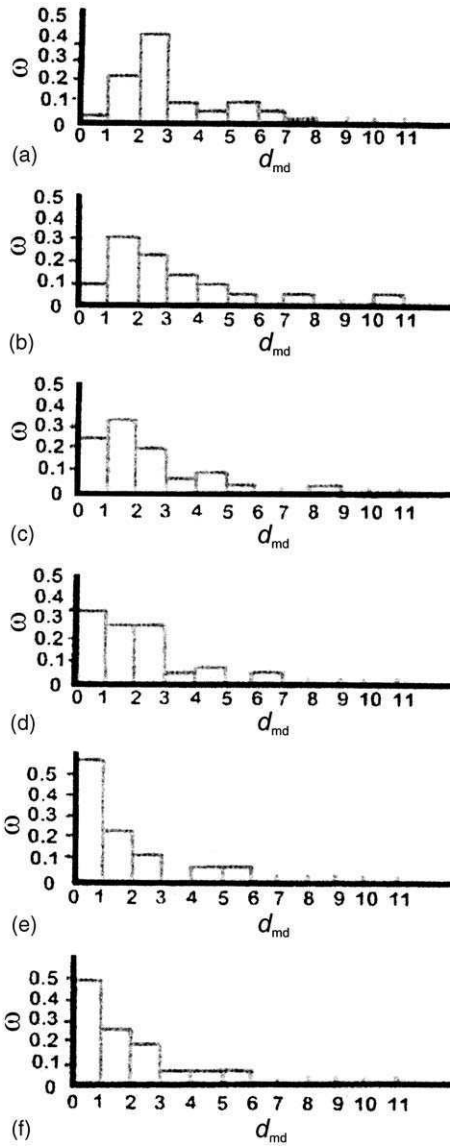

Fig. 3.16. Pore size distribution for argillaceous rocks from the Productive Series of Baku Archipelago, South Caspian Basin (after Buryakovskiy et al., 1986). a — Duvanny Deniz Field, Well No. 529, depth intervals 1415–1420 m/4642–4659 ft and 1450–1455 m/4757–4774 ft; b — same but depth intervals are 1700–1705 m/5577–5594 ft and 1785–1790 m/5856–5873 ft; c — same field, Well No. 275, depth interval 3323–3328 m/10902–10919 ft; d — Sangachal Field, Well No. 534, depth interval 4295–4303 m/14091–14117 ft; e — Bulla Deniz Field, Well no. 537, depth interval 4993–5000 m/16381–16404 ft; f — same field, Well No. 15, depth interval 5128–5132 m/16824–16837 ft.

by the geothermal gradient. Inasmuch as the desorbed (interlayer) water is added to the interstitial water, abnormally high pore pressures may develop if the water cannot escape. Under some conditions, the rising pore pressure in shales may reduce the montmorillonite dehydration rate and release of water. The result will be similar to that arising from a low geothermal gradient, i.e., reduction in the rate of illite formation. Under favorable conditions, the illite may be hydrated, which is accompanied by a release of heat and its transformation to secondary montmorillonite. The relative intensity of dehydration (illite formation) and the illite hydration (formation of secondary montmorillonite) may determine the pore pressure.

The sedimentation rate and the sediment sources do not remain constant with time. Thus, different zones may differ in the dehydration rate because of changes in the sedimentation rate or type of sedimentary material. Transitions from a zone with normal pressures and normal dehydration rate to an AHFP zone may indicate either the effect of diagenetic and catagenetic processes or a lag in the development of these processes. The montmorillonite content may remain the same or even increase with depth. This, however, does not mean that the process of dehydration of montmorillonite to illite is replaced by the illite hydration, although this is possible. Instead, it could mean that dehydration process in the AHFP zones is slow; therefore, these zones may be characterized by higher (or equal) montmorillonite contents than those in the younger zones with normal shale pore pressure.

3.2.5. Effect of formation water chemistry

The formation water chemistry has a significant influence on the intensity of postsedimentary transformations. Thus, it is important to ascertain the nature of hydrochemical scenario observed in the Cenozoic sequence of the South Caspian Basin, namely: whether it is a consequence of diagenetic and catagenetic processes in shales and the transformation of clay minerals, or it is formed predominantly as a result of the action of other factors (e.g., compaction). In this connection, the problem presenting the greatest interest is the origin of inverted hydrochemical profile in the section of the South Caspian Basin, i.e., with depth, calcium chloride waters are replaced by less saline sodium bicarbonate waters. The writers obtained numerous data from the laboratory analyses and field observations, indicating a decrease in the salinity of pore waters in sands with depth. Replacement of calcium chloride water by alkaline sodium bicarbonate water is characteristic for the AHFP zones in the South Caspian Basin areas (Buryakovsky, 1974). Analogous data on the decrease of formation water salinity with increasing pressure were also noted in the Gulf of Mexico (Fertl, 1976).

The appearance of hydrochemical inversion in the stratigraphic section of the South Caspian Basin may be explained by the genetic relationship between the hydrochemical environment and the development of abnormally high pore pressures in shales. The water of primarily sodium bicarbonate type characterizes the

most pronounced AHFP zones in the Baku Archipelago and Lower Kura Depression.

According to Chilingar (1957), the relationship between the chemical composition of the Absheron Peninsula waters and the stratigraphic depth is subject to the following rules:

- (1) The total salinity of formation waters decreases with stratigraphic depth (also see Samedov and Buryakovsky, 1966; Rieke and Chilingarian, 1974, pp. 265–269).
- (2) The Cl^- , Ca^{2+} and Mg^{2+} contents decrease with depth.
- (3) $(\text{Na}^+ + \text{K}^+)$ and $(\text{HCO}_3^- + \text{CO}_3^{2-} + \text{H}^+ + \text{K}^+)$ contents gradually increase with depth.
- (4) The transition from hard-to-alkaline waters occurs at maximum concentration, not exceeding 0.1 g-eq. per 100 g of water ($5-6.5^\circ\text{Be}$). As a rule, the waters are hard at concentration above 0.1 g-eq.
- (5) The HCO_3^- content (in g-eq.) does not exceed the Cl^- content.
- (6) Usually, the waters do not contain SO_4^{2-} anion. If present, however, its concentration does not exceed 0.0004 g-eq. per 100 g of water.

Mekhtiev (1956) (in: Rieke and Chilingarian, 1974, pp. 265) also showed that in the Azerbaijan oilfields water salinity is decreasing with stratigraphic depth and calcium chloride waters ($r\text{Cl}^- - r\text{Na}^+ / r\text{Mg}^{2+} > 1$, where r is percent-equivalent, are gradually replaced by bicarbonate waters: $(r\text{Na}^+ - r\text{Cl}^-) / r\text{SO}_4^{2-} > 1$. For magnesium chloride water, $(r\text{Cl}^- - r\text{Na}^+) / r\text{Mg}^{2+} < 1$. For details on classification of waters, see Chilingar (1956, 1957, 1958), Samedov and Buryakovsky (1966), and Buryakovsky (1974).

According to Chilingarian et al. (1994), the chemistry of pore water is determined mainly by the compaction of argillaceous rocks and squeezing-out of pore water. The formation water chemistry, in turn, influences the diagenetic and catagenetic transformation (of clay minerals) processes.

Fig. 3.17 shows the dependence of montmorillonite content on the total salinity of formation water for the calcium chloride and sodium bicarbonate types of pore waters in sands of the South Caspian Basin. As shown, a direct relationship exists for the sodium bicarbonate type of water, i.e., with increasing water salinity, the conditions for preservation of montmorillonite are improved and its content in the clays increases. Increase in the total salinity of water is caused by an increase in the content of carbonate and bicarbonate salts of alkali-earth metals. Sodium bicarbonate-type waters are present in the Baku Archipelago and the Lower Kura Depression, as well as in the rocks from the Lower Productive Series of Absheron Peninsula and adjacent offshore area, i.e., sections in which the argillaceous rocks are characterized by higher montmorillonite content. There is an inverse relationship between the montmorillonite content and the presence of calcium chloride type of waters. The chloride content [in particular sylvite (KCl)] increases with increasing water salinity. Thus, alkaline medium is apparently favorable for the formation and preservation of montmorillonite.

Thus, the geochemical environment at great depths in the South Caspian Basin deposits not only conducive to the preservation of allothigenic montmorillonite, but possibly allows the transformation of illite into secondary montmorillonite.

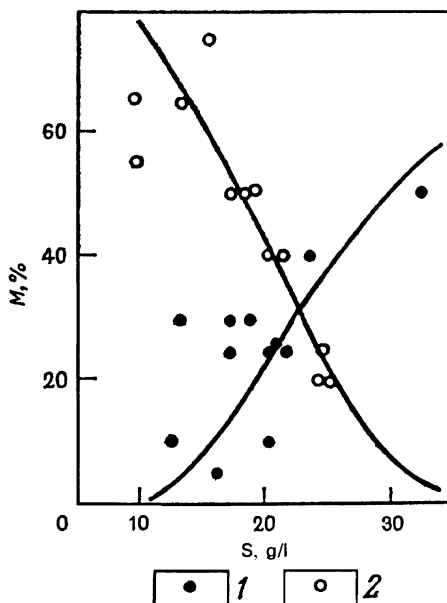

Fig. 3.17. Relationship between the montmorillonite content and total salinity of formation water (after Buryakovskiy et al., 1995, Fig.9, p. 213). Water type: 1 – sodium bicarbonate, 2 – calcium chloride.

3.2.6. Secondary montmorillonite

According to the data cited above, a rather close relation exists between the various clay mineral contents and the formation temperature, pressure, and water chemistry in the stratigraphic section of the South Caspian Basin. The stability of montmorillonite at great depths depends on many parameters. In the section of Baku Archipelago at depths greater than 4–5 km, formation of secondary montmorillonite from illite was observed using SEM. This is explained by the relatively low temperatures, abnormally high pore pressures in shales, and the alkaline pore water enriched in K^+ , Na^+ and HCO_3^- ions (see Buryakovskiy et al., 2001).

The postsedimentary (diagenetic and catagenetic) transformation of Middle Pliocene shales of the South Caspian Basin is characterized by the retardation of the process of transformation of montmorillonite into illite or chlorite at great depths, and the substitution of this process by the process of transformation of illite into highly swelling minerals of the montmorillonite (smectite) group. These processes are closely related to the low geothermal gradient and increasing pressure at depth and inverted hydrochemical profile of these deposits.

3.3. ORIGIN OF ABNORMAL FORMATION PRESSURES

Various origins of abnormally-high formation pressure (AHFP) and abnormally-low formation pressure (ALFP) are discussed in detail by Chilingar et al. (2002). The

classifications of origin of AHFP are presented in Table 3.4 and those of ALFP, in Table 3.5.

Abnormally-high formation pressure (or overpressure) may be created by several mechanisms including:

- (1) Stress-related mechanisms (disequilibrium compaction – vertical loading stress) and tectonic stress (lateral compressive stress).
- (2) Fluid volume increase mechanisms, i.e., temperature increase (aquathermal expansion), mineral transformation – water release due to mineral diagenesis (gypsum to anhydrite transformation, montmorillonite-to-illite transformation), hydrocarbon generation (kerogen maturation – oil or gas generation), oil and bitumen to gas cracking.
- (3) Fluid movement and buoyancy mechanisms, i.e., osmosis and hydraulic head.
- (4) Hydrocarbon buoyancy (density contrasts).

Some of the above listed mechanisms are responsible for creating large amounts of AHFP in sedimentary basins. The most common mechanisms, however, are disequilibrium compaction due to rapid loading of fine-grained sediments in relatively young basins, and the volume expansion associated with gas generation. Mineral transformation (dehydration) may also create AHFP in rocks. Where part of the rock matrix is converted into free fluid (e.g., oil and gas during kerogen maturation or water as a result of montmorillonite-to-illite transformation), the pore fluid will tend to assume that portion of the overburden previously carried by the rock matrix.⁶

Gas generation seems to be a viable mechanism to create regional AHFP by increasing pore pressure. Gas may generate from gas-prone source rocks or can result from the oil to gas cracking.

Other mechanisms, which rely on increased volume of pore fluids, include smectite-to-illite transformation, oil generation, and gypsum-to-anhydrite transformation. AHFP's can be created locally as a result of these processes. The local effect may be additive to other simultaneously acting mechanisms, e.g., regional disequilibrium compaction.

Osmosis may create minor amounts of AHFP if conditions are favorable. Shales do not act as ideal membranes and the amount of AHFP is limited, even at high salinity contrasts (see Chilingar et al., 2003).

Abnormally low formation pressure (or underpressure) as a geological phenomenon is less well known than AHFP. There are several natural events presumably capable to create the ALFP, including:

- (1) Differential discharge – groundwater flow
- (2) Differential gas flow
- (3) Rock dilatancy
- (4) Osmosis
- (5) Thermal effects

⁶Total overburden load (p_t) is supported by the grain-to-grain stress (effective stress) (p_e) plus the pore (fluid) pressure (p_p): $p_t = p_e + p_p$.

TABLE 3.4

Types of mechanisms responsible for generating abnormally-high formation pressures (AHFP) (after Chilingar et al., 2002)

Type of changes	Description of process
<i>Changes in the rock pore volume</i>	
Vertical loading (undercompaction)	<i>Rate of sedimentation and deposition.</i> High depositional rates in clastic sequences and high shale/sand ratios (undercompaction) <i>Massive areal rock salt deposition.</i> Presence of impermeable salt (NaCl) beds. For example, massive salt deposits in USA, Russia, North Africa, Middle East, North Germany, etc.
Lateral tectonic loading	<i>Paleopressures.</i> Sealed-off reservoir rocks experiencing a depth change due to either uplifting or erosion <i>Tectonic activities.</i> Local and regional faulting, folding, lateral sliding, and slipping; squeezing caused by down-dropping of fault blocks; diapiric salt, sand, or shale movements; earthquakes; etc. The pore volume is reduced by horizontal tectonic compression of rock
Secondary cementation	<i>Cementation.</i> Calcium sulfates, sodium chloride, dolomite, siderite, calcite, silica, etc., may act as sealing barriers (“pressure caps”), and directly cause increased pore pressure by decreasing pore space due to crystal grows within closed reservoirs (e.g., NaCl in Markovo oil pool in the Osinskiy Series, Russia)
<i>Changes in the volume of interstitial fluids</i>	
Temperature change (aquathermal expansion)	<i>Thermodynamic effect.</i> Formation temperature increase causes expansion of fluids with consequent increase in the fluid pressure
Mineral transformation	<i>Diagenetic and catagenetic processes.</i> Postdepositional alterations (release of bound water): (1) montmorillonite and mixed-layer clays altered to illites (smectite dehydration); (2) gypsum to anhydrite dehydration

Hydrocarbon generation	<i>Conversion of organic material/kerogen to petroleum.</i> Generation of oil and gas from kerogen (maturation) results in a significant increase in volume
Decomposition of hydrocarbons (thermogenic)	<i>Breakdown of hydrocarbons.</i> About 2- to 3-fold volume increase caused by breakdown of hydrocarbon long-chained molecules into shorter-chained molecules. Such reactions generally occur at depths below 2–4 km and temperatures greater than 70–120 °C. Thermal cracking of organic molecules is initiated at temperatures of 120–140°C depending upon the depth of rocks. At temperatures greater than 180 °C, almost all the hydrocarbons are converted in to methane
Migration of fluids	<i>Gas migration.</i> Upward migration of hydrocarbon gases from lower to upper horizons along faults. This can result in overpressuring of upper horizons
<i>Changes in fluid pressure (hydraulic head); movement of fluids</i>	
Osmosis	<i>Osmosis.</i> Contrasts in the brine concentration of formation fluids can induce the transfer of fluids across a semipermeable membrane. On regional basis, e.g., San Juan Basin, New Mexico; Western Sedimentary basin, Canada; San Joachim Valley, CA, USA, Gulf Coast; and Paradox Basin, IL, USA
Fluid pressure head	<i>Piezometric fluid level.</i> Effect of regional potentiometric surface, e.g., artesian water system. Examples would include the Artesian Basin, FL, USA, Great Artesian Basin, Australia; and North Dakota Basin, USA <i>Structure of permeable reservoir.</i> Pressure transmission to a shallower part of reservoir. Large anticlines, steeply dipping beds, etc
Oilfield production operations	<i>Repressuring of reservoir rocks.</i> Can occur as a result of massive fluid injection or fluid influx into the formation, i.e., massive water injection program (secondary recovery). Pressure increase may occur across faults, or behind casing
Permafrost environment	<i>Formation of frost heaves (pingos).</i> Permafrost environment: trapping of unfrozen zone in practically closed system. Freeze-back pressures around shut-in arctic wells. Gas hydrate reservoirs (e.g., Mackenzie Delta, Canada)
Difference in specific weight	<i>Density difference.</i> Difference between the weight of gas column and that of a fluid (oil or water) column

TABLE 3.5

Types of mechanisms responsible for generating abnormally-low formation pressures (ALFP) (after Chilingar et al., 2002)

Type of changes	Description of process
<i>Changes in the rock pore volume</i>	
Rock dilatancy	<i>Increase in pore volume.</i> During erosion of shallow-buried, clay-rich lithology, dilation of the pores can occur
Tectonic movements	<i>Local and regional faulting, earthquakes, etc.</i> With increase in tension of the formation, the pore volume may increase
Increase in pore volume	<i>Dissolution of cementing material.</i> Dissolution of cementing materials such as CaCO ₃ can increase the pore volume
<i>Changes in the volume of interstitial fluids</i>	
Temperature change	<i>Thermodynamic effects.</i> Cooling of the formation (e.g., due to uplift or erosion) can cause the contraction of fluids and, thus, decrease the fluid pressure
<i>Changes in fluid pressure (hydraulic head); movement of fluids</i>	
Osmosis	<i>Osmosis.</i> Contrast in the brine concentration of formation fluids can result in the transfer of fluids across a semipermeable membrane. This can result in a loss of fluids across a semipermeable membrane with a resultant drop in the fluid pressure, in the upstream side of the system
Production of fluids (gas, oil, and/or water)	<i>Depressuring of reservoir rocks.</i> Can occur as a result of massive fluid production from the formation that is not replaced by an influx of fluids from the adjoining formations, i.e., massive water depletion of producing formations
Migration of gases	<i>Gas migration.</i> During uplift, gas is often able to come out of solution as the temperature and confining pressure is reduced. The freed gas may then escape toward the surface by diffusion or along faults, reducing the pore pressure of the rock
Groundwater movement	<i>Fluid movement.</i> Difference between the permeabilities of discharge and recharge areas, as more fluids are leaving the system than entering it

Reservoirs with ALFP have been recognized mainly in the low-permeability, gas-saturated reservoirs in uplifted basins. The mechanisms for generating underpressured reservoirs relate to changes in the rock and fluid properties during erosional uplift, e.g., as a result of reduction in temperature, rock dilatancy, gas solubility, and groundwater discharge.

This page intentionally left blank

Chapter 4

WATER

4.1. PHYSICAL AND CHEMICAL PROPERTIES OF WATERS

In the environment of the Earth's upper crust, water plays a vital role. Even subaerial deposits became enriched in water content during diagenesis and epigenesis. Water reaches a maximum density at $+4^{\circ}\text{C}$. Its critical temperature is 374°C and its critical pressure is 21.8 MPa. Water density declines as its composition changes from hard to alkaline. Water viscosity is 1.789 cp at 0°C and 0.282 cp at 100°C . Water viscosity decreases with increasing temperature and increases with increasing density and content of calcium and magnesium. Water can reach its critical pressure at a depth of about 2000 m, which affects some features of the hydrocarbon habitat in the Earth's crust (for instance, hydrocarbon dissolution). Water is a stable chemical compound. Noticeable decomposition of water occurs at a temperature of greater than $2,000^{\circ}\text{C}$.

At great depth (about 100 km), when pressure is nearly 1,000 MPa and temperature is $600\text{--}900^{\circ}\text{C}$, electrons are totally or in part torn-off from the atoms; the atoms are close together and are tightly packed. In such an environment, water as a chemical compound, H_2O , cannot exist. Water dissociation into H^+ and OH^- ions under standard conditions is low — a mere 10^{-7} . The amount of free hydrogen ions in water substantially affects its properties as solvent and catalyst for various chemical reactions. The pH is the negative logarithm of H^+ concentration. Alkalis and alkaline earth's metals increase the pH. At $\text{pH} = 7$, the medium is neutral; when pH is greater than 7, it is alkaline, and when pH is lower than 7, it is acidic.

The pH of the ground water ranges from 5.6 to 8. The pH is strongly affected by CO_2 content in water and much less affected by H_2S , HCl , and some other volatile components. An increase in CO_2 content in the water lowers pH. Consequently, at depth, the stability domain for various minerals shifts.

The interfacial tension between the water and oil is highest for hard water (22.671–5 N/cm) and lower, for the alkaline water (4.471–5 N/cm). The greater the time of contact between the oil and water, the lower is the interfacial tension. In case of bacterial infestation, a clear interface between the oil and water may be absent.

Water compressibility is very low. Bulk volume elasticity coefficient for the oilfield formation water lies between 3×10^{-4} and 5×10^{-4} MPa. Dissolved gases in the water and increasing temperature drastically raise the bulk volume elasticity coefficient. In petroleum engineering, the formation volume factor (FVF) is calculated by dividing the water volume at reservoir conditions by its volume under standard conditions (0.1 MPa, 20°C).

Heat conductivity of water depends on the concentration of dissolved salts and temperature and can be determined by logging (see Khilyuk et al., 2000).

Radioactivity of formation water is determined by the presence of dissolved radium, uranium, radon, and thorium compounds. Their content in oilfield formation water is as low as 10^{-7} – 10^{-11} .

The capability of water to dissolve gaseous hydrocarbons is reviewed in Chapter 6. Liquid hydrocarbons under standard conditions (0.1 MPa and 20 °C) are almost insoluble in water. A film of surface tension is clearly observed between water and liquid hydrocarbons. This solubility increases as temperature and pressure increase. This process is especially clear at a temperature of about 150 °C and near-critical pressure (21.8 MPa). The critical point of the water–oil binary solution is not studied well. Besides, such a solution can hardly be called “binary,” because the oil itself is a complex system of interacting components with very diverse critical temperatures and pressures.

The study of critical temperature of oils is not easy, because their flash points are often below their critical temperatures. There is a drastic increase in the solubility of liquid hydrocarbons in water with increasing temperature and upon exceeding the critical pressure of water.

If oil is not completely dissolved in water, chemical composition of the dissolved oil may be substantially different from that of the original oil. Light oil is more soluble in water than the heavy oil, and its critical temperature is lower than that of the heavy oil. Possibly, the relatively light oils may have a high solubility at lower temperatures (below 100 °C). The reason for the latter supposition is that the solubility of hydrocarbons belonging to the same chemical type decreases with increasing molecular weight. With the same number of carbon atoms in the molecule, aromatic hydrocarbons are more soluble than the other hydrocarbons.

The writers did not analyze here the colloidal–emulsion solution mechanism of hydrocarbons in water (although sometimes this type of solubility may be higher than the true solubility). The reason is that the colloidal–emulsion solution mechanism appears to play a very limited role in the hydrocarbon transfer in nature.

Beletskaya (1990, p. 40) lists the following reasons for this:

- (1) difficulties associated with the micelle movement in the pore space of rocks;
- (2) destruction of colloids with temperature increase;
- (3) adsorption of surfactants by rocks and the destruction of micelles and emulsions;
- (4) electric barrier — hydrocarbon micelles are negatively charged, are hydrophilic, and move with difficulty along the mineral surfaces;
- (5) the need for the presence of surfactants at reservoir conditions to a degree sufficient to overcome the barrier of the critical micelle-formation concentration.

Beletskaya (1990) stresses the fact that surfactants lose their properties with increasing temperature. In the experience of writers, water-in-oil emulsions break at higher temperatures.

On basis of the aforementioned fact, it is reasonable to suggest the absence, in many cases, of a clear-cut oil–water contact (OWC) and the presence of a transition zone. A stable oil–water emulsion can form within a transition zone as a transitional state between the two immiscible liquids. The thickness of the transition zone depends on the chemical properties of oil and water and on the subsurface

temperatures and pressures. It may be suggested that in some specific situation the transition zone can actually extend over the entire thickness of the accumulation. The following accumulations may be placed in this group:

- (a) those where the OWC was determined from logs at the level of 50% oil saturation (a quite frequent case); or
- (b) those where the OWC was determined at the depth of perforated interval that produced water-free oil, which is not rare.

In the latter case, one may also anticipate the effect of relative permeability. The relative permeabilities to oil and to water depend on the rock properties (oil-wet versus water-wet), alkalinity⁷ of water, and the presence of polar substances in oil. The relative permeability to oil increases with increasing amount of polar substances in the oil, whereas the relative permeability to water decreases (Langnes et al., 1972, pp. 228–230). In the presence of alkaline water, the relative permeabilities both to oil and to water increase (Fig. 4.1).

A typical relationship between the relative permeability and capillary pressure, as well as the effect of these two parameters on productivity, is illustrated in Fig. 4.2.

Despite numerous studies, the structure of the liquid water represents an unsolved problem. Most scientists believe that there are two types of water: (1) the first type forms a tetrahedral grid and (2) a portion of molecules of the second type is located within the tetrahedral frame and are connected with it by *n*-bonds. These *n*-bonds completely disintegrate upon reaching the critical temperature. When the ice melts, a

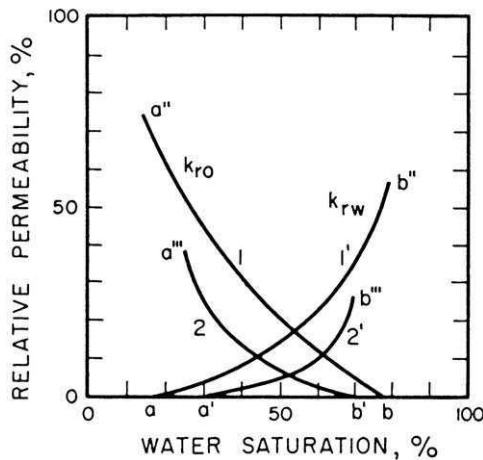

Fig. 4.1. Relative permeability curves for polar oil+alkaline water (curves 1 and 1') and for polar oil+hard waters (curves 2 and 2') (modified after G. A. Babalyan, in: Langnes et al., 1972, p. 229).

⁷For alkaline water. $rNa^+/rCl^- > 1$; $(rNa^+ - rCl^-)/rSO_4^{2-} > 1$; $(rNa^+ + rCl^-) > rSO_4^{2-}$; $rHCO_3^- > rCa^{++} + rMg^{++}$; $rNa^+ + rK^+ > rCl^- + rSO_4^{2-}$. For hard water, $rNa^+/rCl^- < 1$; $(rCl^- - rNa^+)/rMg^{++} > 1$; $rCl^- + rSO_4^{2-} > rNa^+ + rK^+$ ($r = \%$ -equivalent).

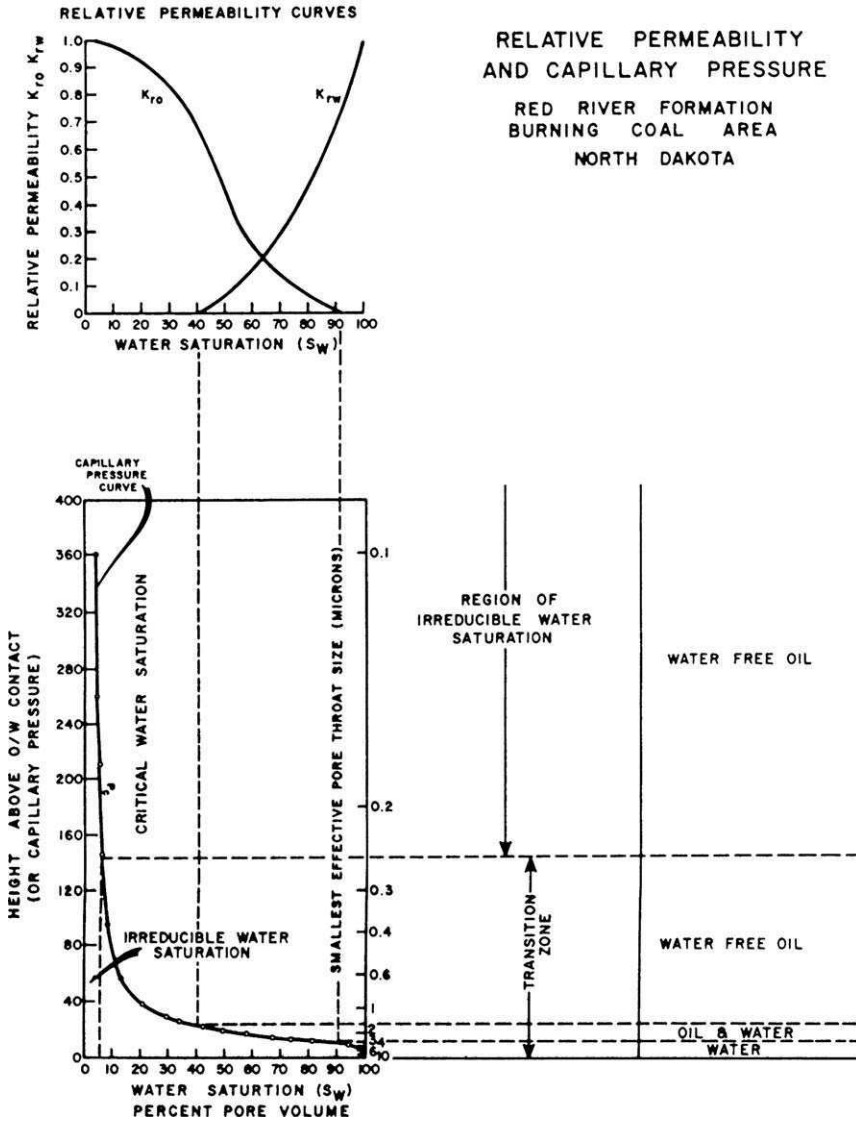

Fig. 4.2. Reservoir-rock productivity as determined from capillary pressure and relative permeability curves (modified after J. J. Arps by R. L. Jodry, in: Chilingar et al., 1972, p. 53). Smallest pore throats effective at any pressure level are shown on scale to the right of capillary pressure curve.

portion of molecules leave the frame and move into the pores, thereby increasing the water density.

The structure of water solutions depends on the structure of water and the dissolved substances. There may be a positive and negative hydration. The former one increases, whereas the latter decreases the n -bonds in solution. The solubility of

liquid and gaseous non-electrolytes declines when charged ions appear in the solution, which facilitates their precipitation out of solution.

Hydrogen and oxygen in water may have different isotopic composition. Three hydrogen isotopes (protium H, deuterium D, and tritium T) are encountered in water. The first one predominates. The D/H ratio ranges from 1/8,400 to 1/3,800. Only tritium is radioactive; it is very scarce (T/H ratio is usually negligible — about 10^{-18}).

Six oxygen isotopes are known: ^{14}O , ^{15}O , ^{16}O , ^{17}O , ^{18}O , and ^{19}O . The ^{14}O , ^{15}O , and ^{19}O isotopes are radioactive, but with a short half-life. The most common isotope is ^{16}O .

Water density ρ depends on the isotope composition of water ($\rho = 10^{-6}d$, where d is the water density at 3.98 °C in g/cm^3). Surface water and the water within the free circulation zone are of normal density. Water density increases within the zones of stagnation (limited circulation).

The amount of dissolved and colloidal substances in the water is represented by its salinity. The salts are chlorides, sulfates, and bicarbonates of alkaline and alkaline-earth metals. It is assumed that these salts totally dissociate in water into the equal number of cations and anions. This assumption forms the basis for the ion-equivalent presentation format of the water composition. This is true for weak solutions, but is not justified when the concentration of salt is high. This is important to remember when interpreting electric log; there is no straight-line relationship between the water salinity and the electric conductivity of water.

Mineral composition of ground water may be expressed in terms of weight (mass) (as g/l, g/kg, g/100 g), or in terms of equivalents. To obtain the latter, the weight is divided by the ion-equivalent value. The sums of anion and cation equivalents are considered to be equal to 100%, and the ion percent-equivalent is calculated on this basis.

4.2. CLASSIFICATIONS OF OILFIELD WATERS

Waters can be classified in a number of ways. Most commonly they are grouped according to the following criteria:

- (1) water origin — meteoritic, connate, or juvenile waters,
- (2) water chemistry, e.g., bicarbonate, sulfate, or chloride waters, and
- (3) total water salinity, i.e., fresh water, saline water, or brine water.

Many chemical classifications have been proposed or discussed by Tolstikhin (1932), De Sitter (1947), Durov (1948), Sulin (1948), Vassoyevich (1954), Chebotarev (1955), Krejchi-Graf et al. (1957), Gorrell (1958), Rainwater and White (1958), Chave (1960), and Eremenko (1960), to mention just a few investigators. For example, see Table 4.1 (in: Eremenko and Chilingar, 1996). The water classifications have been reviewed in Chilingar (1957, 1958), Chilingar and Degens (1964), and Samedov and Buryakovsky (1966).

As an example, the classification scheme of N. I. Tolstikhin (in: Vassoyevich, 1954, p. 112) is presented in Fig. 4.3. It is based principally on the distribution of the most abundant cations (Na^+ , Mg^{2+} , Ca^{2+}) and anions (HCO_3^- , Cl^- , SO_4^{2-}). In following

TABLE 4.1

Comparison of Three Different Classifications of Water based on Ionic Content (in: Eremenko and Chilingar, 1996)

After V. A. Sulin	After O. A. Aleksin	After M. G. Valyashko
Bicarbonate-sodium	$r\text{HCO}_3^- > (r\text{Ca}^{2+} + r\text{Mg}^{2+})$	Carbonate
Sulfate-sodium	$r\text{HCO}_3^- > (r\text{Ca}^{2+} + r\text{Mg}^{2+}) < (r\text{HCO}_3^- + r\text{SO}_4^{2-})$	Sulfate type, sodium subtype
Chloride-magnesium	$(r\text{HCO}_3^- + r\text{SO}_4^{2-}) < (r\text{Mg}^{2+} + r\text{Ca}^{2+})$	Sulfate type, magnesium subtype
Chloride-calcium	$(r\text{HCO}_3^- + r\text{SO}_4^{2-}) < (r\text{Ca}^{2+} + r\text{Mg}^{2+})$ HCO_3^- is absent, water is acidic	Chloride

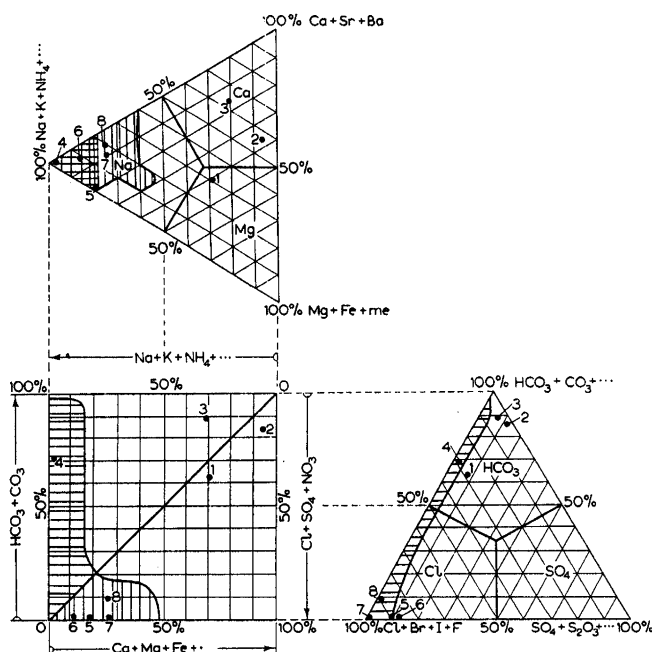

Fig. 4.3. Graphical representation of chemical composition of oilfield waters: vertically lined areas represent calcium chloride waters; horizontally lined areas represent alkaline waters (after Tolstikhin, in: Vassoyevich, 1954, p. 112). Sampling areas: (1) Lake Onega; (2) Darasun mineral springs; (3) Lake Baikal; (4) Okha oilfield waters, Sakhalin Island; (5) World Ocean; (6) Usol'e Sibirskoye; (7) Ukhta oilfield waters, Russia; and (8) Grozny oilfield waters, Russia.

this scheme, one may chemically classify water, for instance, as sodium bicarbonate type, or calcium chloride type, depending on the position the prospective water occupies in the diagram. The representative oilfield waters fall within the dashed area. Additional information on the chemistry of petroleum brine waters and their genetic coefficients is presented in Table 4.2 and Fig. 4.4.

TABLE 4.2

Comparison of Chemical Composition of Marine and Oilfield Waters of Azerbaijan (after Mekhtiev, 1956, p. 303)

Location	Percent-equivalent (<i>r</i>)						Palmer's salinity and alkalinity coefficients			
	Cl ⁻	SO ₄ ²⁻	HCO ₃ ⁻	Ca ²⁺	Mg ²⁺	Na ⁺ + K ⁺	<i>S</i> ₁	<i>S</i> ₂	A	a
Karachukhur (NKP)	—	0.39	5.82	0.08	0.69	49.23	89.76	—	10.52	1.52
Balakhany-Sabunchi-Ramany (PK)	31.77	—	19.23	0.81	1.01	48.18	60.06	—	36.38	3.56
Bibieibat (unit VII)	49.58	—	0.42	4.44	5.35	40.21	80.40	18.80	—	0.80
Neftechala	49.74	0.23	0.03	11.02	4.70	34.28	66.96	32.98	—	0.06
World Ocean	45.22	4.62	0.16	1.77	8.92	39.31	78.60	21.10	—	0.30
Caspian Sea	34.58	14.51	0.91	3.81	13.81	32.28	64.56	33.62	—	1.82

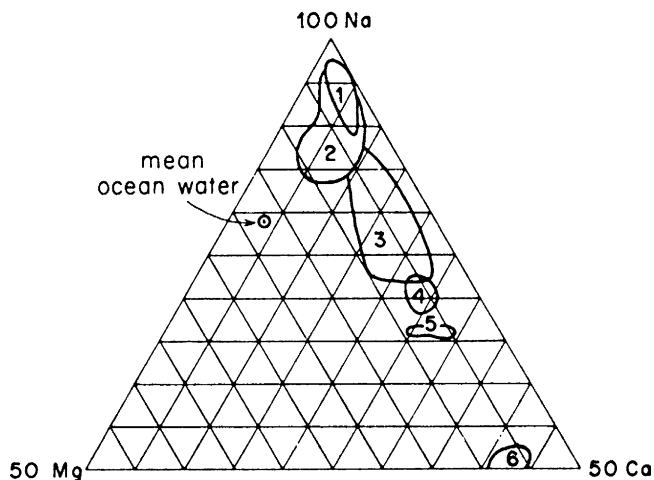

Fig. 4.4. Cations in petroleum brine waters (after De Sitter, 1947; and von Engelhardt, 1960). Water samples: (1) Woodbine Sand, Texas (Cretaceous); (2) California (Tertiary); (3) Kansas and Oklahoma (Paleozoic); (4) Appalachian (Mississippian); (5) Appalachian (Upper Devonian); and (6) Arkansas (Jurassic).

The chemical composition of formation waters can be used as an indicator for the presence of petroleum (V. A. Sulin, in: Vassoyevich, 1954):

- (1) Sodium sulfate type $(rNa - rCl)/rSO_4 < 1$. The sodium sulfate type of formation waters is a usual representative of uncovered formations and, therefore, is not a favorable indicator of the presence of oil. These waters, however, could be present in the uncovered zones of petroleum deposits.
- (2) Sodium bicarbonate type $(rNa - rCl)/rSO_4 > 1$. The high content of bicarbonates or sodium chloride, negligible sulfate content, and the presence of hydrogen sulfide, naphthenic acids, iodine, and other microcomponents, which are characteristic of the oilfield waters, make this kind of sodium bicarbonate formation water a favorable indicator for the presence of petroleum.
- (3) Magnesium chloride type $(rCl - rNa)/rMg < 1$. In general, the magnesium chloride type of waters is not a direct indicator for the presence of oil. These waters, however, are sometimes found in petroleum deposits.
- (4) Calcium chloride type $(rCl - rNa)/rMg > 1$. The presence of microcomponents which are characteristically found in oilfield waters (iodine, naphthenic acids, bromine, and boron) and insignificant quantities or absence of sulfates are of considerable importance in deciding as to whether the calcium chloride type of water is a favorable hydrochemical indicator or not.

The presence of calcium chloride type of waters having high content of salts, but containing considerable amounts of sulfates and devoid of iodine or naphthenic acids, is indicative only of a well-sealed formation.

The specific hydrochemical indicators for the presence of oil include:

- (a) naphthenic acids — direct hydrochemical indicator;
- (b) iodine (in high concentration) — supposedly a direct hydrochemical indicator;

- (c) bromine — does not have a genetic relationship to oil; however, many oilfield waters characteristically contain high concentrations of bromine;
- (d) boron — supplementary hydrochemical indicator, which is more common in the bicarbonate type of waters;
- (e) ammonium — indirect hydrochemical indicator; and
- (f) barium and strontium — supplementary indicators, which do not have genetic relationship to petroleum.

The presence of organic components is the most typical feature of oilfield water. The presence of liquid and gaseous hydrocarbons in water facilitates reduction processes (especially near the hydrocarbon accumulations) and the appearance of various organic substances in water.

The reduction of sulfate ions results in the formation of hydrogen sulfide. The generated hydrogen sulfide diffuses into the surrounding rocks and reacts with the oxides of iron, forming pyrite and siderite. The rocks even change in color from reddish and greenish to gray and dark-gray. These indications are considered as favorable in exploration. The presence or absence of sulfates in the subsurface water is not an indicator: concentration of sulfates in water depends not only on the reduction processes but also on the input of the SO_4^{2-} ions from the surrounding rocks. The sulfate reduction is possible at rather high temperatures (300–500 °C). The writers believe that the sulfate reduction may occur at lower temperatures, at a slow rate, in the low-pH environments. Microorganisms can reduce sulfates at temperatures even as low as 70 °C. For example, *Desulfovibrio desulfuricans* in injection waters can reduce sulfates to sulfides and convert “sweet” oilfield waters into “sour” ones.

Oilfield waters are highly reduced. The extent of the reduction is evaluated from the amount of oxidizing substance, potassium iodate or permanganate. The oilfield waters are also enriched in volatile and non-volatile phenols and fatty and naphthenic acids. Up to a temperature range of 120–150 °C, liquid hydrocarbons are barely soluble in water. Currently, the only compound that was clearly identified was benzene, which is typical for water in the accumulations of highly aromatic condensates. When water is moving, gaseous hydrocarbons soluble in water form, in terms of their concentration, front and back effects. Same effects are typical for all other geochemical indicators.

Oilfield waters contain iodine, bromine, boron, aluminum, and mercury. Gas and gas-condensate accumulations usually have elevated amounts of iodine in brines. High-salinity brines contain bromine, whereas alkaline water is enriched in boron. Formation water of gas accumulations contains mercury. Various nitrogen-rich substances (such as amines and complex heterocyclic compounds including pyridine) are also found in brines.

4.3. WATER DRIVE

Subsurface water is encountered in a solid state (“ice”), liquid state, and steam (at high temperature). Interstitial water may be free to move or is bonded (residual, irreducible water). Free water is subdivided into gravity water and capillary water.

Gravity water can move as a result of gravity force, obeying the Darcy's law; it transmits the hydrostatic pressure. Surface tension affects the water not as strongly as the gravity force, and has only slight effect on permeability. With increasing role of interfacial tension, water can be classified as "capillary." Thus, gravity can be in equilibrium with interfacial tension. Capillary water can also transmit hydrostatic pressure, but very slowly (within the lower limit of applicability of Darcy's law). A further increase in the role of interfacial tension results in the appearance of loosely bonded water (film water, physically bonded water).

The properties of film water are quite different from that of free water. It moves according to the law of diffusion toward equalization of the film concentration on the grain surfaces. Firmly bonded water (adsorption water) is retained in place by surface tension ($> 1,100$ MPa), but is easily removed as steam with increasing temperature. Upon thermolysis, the first peak occurs at a temperature above 100°C . Some authors (see e.g., Beletskaya, 1990; Simonenko, 1988) call this firmly bonded water a "sub-melted" water layer, $0.01\text{--}0.006\ \mu\text{m}$ thick. This layer can move somewhat easier than the physically bonded water. The molecule orderliness, viscosity, and shear strength in such "sub-melted" water are less than in the irreducible water (Tsarev, 1978).

When a hydrocarbon accumulation is formed, hydrocarbons push the free water out of the accumulation, whereas the capillary water is retained. After the oil and gas are produced, the equilibrium in the reservoir changes. The "sub-melted" and some capillary water is produced and may account for between a fraction of one percent and a few dozen percents of the production. The content of such water depends on surface phenomena, and that is why this content is greater in beds with greater active surface. In a clay-sand-carbonates series, the content of such water decreases in the reservoirs as well as in the produced fluids. Gas produced from carbonate reservoirs may contain as low as 1% of water.

There are transitions between the aforementioned types of water. Sometimes more detailed subdivisions are used, such as mono- and poly-molecular layers (i.e., the number of molecules in a layer), in the water film surrounding the grains. If bonded water becomes free, its general properties change: density increases, and the solution capacity decreases. Thus, the released bonded water is fresher and aggressive.

Chemically bonded water is a constituent part of minerals. It includes the crystal-hydrate (zeolite) and constitution waters. The amount of crystallization water in minerals is not constant and may be removed by heating to $450\text{--}500^{\circ}\text{C}$. Interlayer montmorillonite water is the crystallization water. A mineral does not necessarily decompose after the removal of crystallization water. It may only change its form (e.g., gypsum \rightarrow anhydrite; montmorillonite \rightarrow illite). The removal of the constitution water, on the other hand, results in the destruction of mineral. It occurs when temperature exceeds about 500°C .

4.3.1. Water drive systems

The studies of water drive systems in the oil (gas) fields and basins followed the studies of hydraulic systems in artesian basins. The term "oil/gas basin" was adopted

from the latter studies because some writers tied-in the very formation of oil and gas accumulations with the development of artesian systems.

As long as the shallow and relatively young hydrodynamic basins were being studied, there were no significant contradictions. Water intake (recharge) and possible discharge areas were identified in most cases. Abundant rains in the Caucasus Black Mountains resulted in raising the static water levels in wells of the Old- and New-Grozny oilfields after 1–1.5 months. By adding tracers to water, the movement of water sometimes could be recorded up to a few dozen kilometers.

Such basins have the water (infiltration) drive. Water moves from the recharge areas (nearby hilly or mountainous regions) to the discharge areas (open: e.g., springs and rivers, or concealed: such as, cross-flow into different horizons). Water velocity is quite high (in tens of meters per year), depending on the hydraulic head drop from the recharge to the discharge area. No overpressure or abnormally-high pressure is observed in the associated oil and gas accumulations. The water has low salinity. The environment is oxidizing, especially in the first few hundred meters from the surface (although the free oxygen disappears after less than a few tens of meters).

Some geologists believe that the presence of infiltration drive is unfavorable for the oil and gas generation. The presence of numerous accumulations (some of them quite large) in such cases is believed to be due to subsequent migration. The writers, however, believe that a conventional view of the accumulations being destroyed by the infiltration water is somewhat exaggerated.

The oil accumulations can be destroyed in several ways:

- (1) Washing-out of the oil from accumulations by the way of tangential transmission of water movement, layer-by-layer, up to the static oil accumulation. This process is unlikely at reservoir environment because it requires a very high speed of water movement. P. A. Antonov (in: Eremenko and Chilingarian, 1996, p. 53) calculated that velocity will be over 20 cm/s for a permeability of 500 mD, which is impossible in a basin.
- (2) Chemical dissolution of liquid hydrocarbons in water and their delivery to the surface. As previously mentioned, solubility of liquid hydrocarbons in water at surface or near-surface environments is very low, so that it would take a few tens of millions of years to destroy even a medium-size accumulation.
- (3) Oxidation of the oil in accumulations through the action of aggressive water. In such a case, a layer of oxidized oil forms between the oil and water. This layer protects the accumulation from further destruction. It is similar to the asphalt plug in an oil-bearing bed at its surface exposure; the difference is that the light fractions of oil cannot be vented into the atmosphere.
- (4) Squeezing-out the oil deposit out of the trap owing to the pressure drop at the contour (Hubbert's principle; see also Savchenko, 1977). Although this is plausible, the process is very slow and is controlled by the reservoir permeability and by the inclination angle of the barrier. In order for the accumulation to be destroyed, the water/oil separation dip angle must be greater than that of the inclination angle of the barrier.

A totally different situation occurred in the deeply buried basins, where compaction and squeezing-out of water from the rocks are still continuing (see the

sections on rocks: squeezing-out of water, different heat expansion rates, and neof ormations). Water-head distribution in such basins is inverted. Water-head decreases from the deepest portion toward the edges. N. B. Vassoyevich (in: Eremenko and Chilingar, 1996, p. 53) proposed to call such basins “elision” basins. The water-head in such a basin reflects the potential energy distribution, i.e., an opportunity for reservoir water to move from the basin center to its periphery. This can happen, but slowly. The distribution of anomalous pressure, which forms, follows a certain pattern: higher in the center, decreasing upslope to a total disappearance at the edges.

Reservoir water is saline, sometimes with the geochemical inversion (salinity decreases with depth) and the reducing environment. The best oil and gas potential exists in the “elision” water-head complexes. Oil and gas accumulations, formed during the formation of stratigraphic sequences, are associated with the periphery of present-day and ancient depressions, separated by highs and with major swells present in the way of possible underground water movement (Bars, 1984). This overconfident statement may well be true but is difficult to prove: comparable amounts of hydrocarbons are known in basins with different hydrodynamic regimes.

Further evolution in such basins may create reservoirs cut into blocks, which changes basin parameters. Inasmuch as the individual fault blocks are isolated from one another, the anomalous pressure in each one is distinct. This also stops or at least substantially limits the lateral migration. Numerous faults along and across the strike make the vertical migration within the formation, and sometimes outside of it, easier. The water composition does not change gradually but rather in a stepwise manner. Changes in the water composition are easier to identify in the section rather than in a lateral direction. The communication with the surface occurs along the basin periphery where the thickness is lower. A typical infiltration drive arises there.

This kind of a combination/isolated differential drive is quite common but has not been named yet. Together with the infiltration and “elision” drives, Beletskaya (1990, p. 34) distinguishes the thermohydrodynamic (deep subsurface) drive. She, however, does not provide its description. The Mesozoic sequence of the North Caucasus region is a typical example. Gas accumulations there are encountered at the transition boundary between the block-isolated (deep subsurface) drive and the infiltration drive. Before some other basins are studied in this respect, it is difficult to tell at this time to what extent this phenomenon is common for the basins with combination/isolated drive.

The appearance (or the preservation) of the infiltration drive is quite possible in the basins with a typical “elision” drive. Such may be the Paleozoic basins in the Volga-Ural Province. This, however, does not involve the entire basins. The deepest portions of basins may preserve the “elision” drive with its characteristic anomalous pressure. Still, this anomalous pressure is usually significantly lower than that at an equal depth in typical younger “elision” basins.

At this time there is no technique or reliable parameters available to distinguish between the preserved infiltration drive and the re-infiltration drive. It is quite possible, however, to eventually develop such technique.

In studying the water drive systems, the most important variable is the potential energy (including elastic energy). Energy distribution in the reservoirs determines the possible directions of fluid (oil, gas, or water) flow. The latter can occur if the migration avenues are available.

Pressure distribution in the reservoir rocks affects the piezometric surface. The piezometric surface passes through the points to which the water can rise in different wells. If the water has uniform density, its movement is possible only if the piezometric surface is inclined.

In 1933, Zhdanov proposed to use a concept of normalized pressure⁸ for the water movement calculations. The World Ocean surface is used as a datum plane. The datum is considered to be the zero energy surface. All water located either above or below this surface tends to attain this level. This concept is not exact for at least two reasons:

- The zero energy value is arbitrary.
- The World Ocean surface is not horizontal (i.e., geoidal); it has minima and maxima caused by the gravitational forces of the Earth.

These objections, however, may be neglected for routine hydrodynamic calculations. All such calculations and construction of piezometric-surface maps utilize only the differences in liquid column height (at equal density). Any arbitrarily selected surface may be chosen as a datum plane (this does not affect the height difference used in calculations). Thus, when calculating normalized pressure, the pressure (in atm, Pa, kg/cm², or lb/ft²) measured in the reservoirs is expressed as height of a corresponding water column with specific gravity equal to one (Fig. 4.5).

Absolute pressure in a water-filled anticline trap (water is not moving) increases from the crest toward the flanks. The isobars are parallel to the depth contours. The normalized pressure at all points of isobar is the same. This is not the case if a trap is filled with oil or gas. At the hydrocarbon–water interface (if there is a contact, and if the water drive is an infiltration one) pressure will be equal to a hydrostatic one, and up the section it will be determined by considering the surpressure (see above).

In the case of moving water, the piezometric surface is inclined toward the direction of water movement due to the pressure drop. The OWC will also be tilted. The following equation is proposed for determination of the tilt angle α of an OWC surface, using the tilt angle β of piezometric surface and densities of water, ρ_w , and oil, ρ_o :

$$\tan \alpha = \frac{\tan \beta \rho_w}{\rho_w - \rho_o}$$

The slope of the OWC increases with increasing pressure drop and decreasing density difference. At reservoir conditions, the gas and oil densities are lower than that of water (specific gr. water > 1) and the denominator in the above equation is less than 1. Thus, the inclination angle of the OWC in this case is greater than the one for piezometric surface ($\alpha > \beta$).

⁸ $p = \gamma h$, where p = the pressure, for example, in lb/ft², γ = the specific weight of fluid in lb/ft³, h = the height of fluid column in ft.

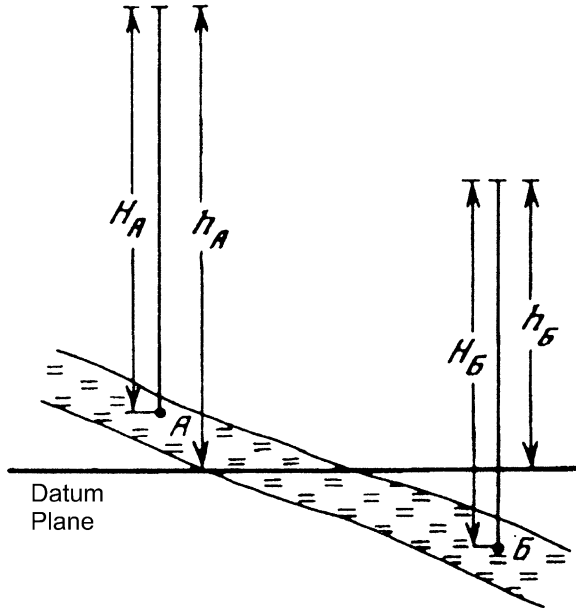

Fig. 4.5. The concept of normalized pressure. H_A is the height of the liquid column at point A (pressure head at point A), H_B the height of the liquid column at point B (pressure head at point B), h_A = the normalized height of liquid column at point A (normalized pressure head at point A), h_B = the normalized height of liquid column at point B (normalized pressure head at point B). $(H_A + z_A) - (H_B + z_B) = h_A - h_B$, where z_A is the potential head at point A, z_B the potential head at point B. p_A (pressure at point A) = $\gamma_f H_B$; p_B (pressure at point B) = $\gamma_f H_B$, where γ_f is the specific weight of fluid. If specific weight is in lb/ft^3 and H is in ft, then pressure is in lb/ft^2 .

The above analysis enables one to formulate the main condition for the preservation of an accumulation within a hydrodynamic trap. The inclination angle of the OWC must be lower than the dip angle of the trapping flank. If these two angles are equal (and even more so, if their magnitudes are reversed), the accumulation can be squeezed-out of the trap down-dip. The speed of squeezing is determined by the speed of water flow, which is rather slow in a porous medium (Darcy law). All this is true when the water density remains constant.

If the subsurface water density changes only vertically and remains constant along any horizontal plane, the A. I. Silin-Beckchurin or M. Hubbert equation⁹ can be used to calculate the normalized pressure (p_{norm}):

$$p_{\text{norm}} = p + \int_{z_0}^z g\rho(z) dz$$

where $\rho(z)$ = the water density changing in the vertical direction, z_0 = the elevation of a comparison (reference) surface (horizontal datum plane) with equal normalized pressure, and g = the gravitational acceleration.

⁹ $\Phi = g(z - z_0) + (p - p_0)/\rho$. If the datum plane is taken at sea level [$z_0 = 0$ and $p_0 = 0$ (atmospheric pressure)], the equation becomes $\Phi = gz + p/\rho$.

If in the above equation the density is changing linearly, and z_o is at the sea level, then:

$$p_{\text{norm}} = p + \frac{g(\rho + \rho_o)}{2} z$$

If the water density does not remain constant both horizontally and vertically, neither of the above techniques is applicable. In such a case, a vector of the filtration force for limited bed volume is calculated.

As Gattenberger (1984) stated, “the possibility of obtaining objective information on the subsurface water movements based on the analysis of static levels (Hubbert’s potentials) or normalized pressure is available only if the changes in the static levels, potentials, or normalized pressure drops are greater than their combined calculated error.”

In order to better define the role of hydrochemical and geochemical studies in the field surveys (and production), the following formation water classification is presented below:

1. *Lower edge water.* The lower edge water resides within the same reservoir as the accumulation outside the OWC/GWC. In case of hydrodynamic drive, such water is the main source of the potential energy pushing oil (and, to some extent, gas) toward the well. This is clearly observed at depths with pressures close to the critical one for water (2–2.5 km). Approximately at that depth a distinct water–oil (gas) separation disappears to be replaced by a transition zone (see above). All previously developed concepts and practical recommendations as to the “contour” behavior at these conditions must be reconsidered.
2. *Upper edge water.* The upper edge water occurs within the same reservoir as the oil (gas) accumulation, up-dip of it in a monocline or the flank of a structure. It is rare, which may be simply due to the lack of knowledge: it was believed that such an occurrence is impossible. As Confucius remarked, “no sense in trying to catch a black cat in a dark room if the cat is not there.” The first mention of such a water goes back to the early 20th century when it was encountered (Gubkin, 1915) in the so-called “inlet-like” oil accumulations in the Maykop Formation (Krasnodar Region, Russia). At that it did not receive a due attention (“a black cat”). The existence of such water may be explained by the change in porosity, and the capillary forces. This explanation, however, was not valid in the case of San Juan Field in Alberta, Canada. There, a gas accumulation in a 3,000-ft-high syncline (surplus pressure of over 30 MPa), is trapped by the upper edge water with a simultaneous increase in the porosity up-dip from 14% to 25% and increase in the average pore diameter. The pressure increases from the syncline flanks to its trough. Two possible explanations were proposed: (a) change in the wettability of rock properties from hydrophilic to hydrophobic and (b) the volume of currently forming gas exceeds the gas loss due to migration through the upper edge water.
3. *Bottom water.* The bottom water occurs within the same reservoir as the oil (gas) underneath the entire accumulation or its near-edge portions. Reservations expressed above (No. 1) are applicable.

4. *Formation water*. Usually, a well producing 1–2% of water is called “water free;” 100% water-free wells are rare. Formation water has diverse origins, potential energy, and chemistry. If this water is fresh or has very low salinity, its origin could be due to condensation out of the gas phase (if present), when the formation pressure or the bottomhole pressure drops. Formation water may have been earlier isolated in hydrodynamic traps (small interbeds, lenses, etc.) or may have been present throughout the reservoir. When the water coning or fingering occurs, such water can substantially accelerate the water encroachment process.
5. *Intermediate water*. The intermediate water is associated with thin interbeds within an oil/gas-producing interval. When the volume of such water is low it is possible to assign it to the previous category.
6. *Upper water*. The upper water is associated with independent overlying aquifers.
7. *Lower water*. The lower water is associated with independent underlying aquifers.

The identification of water category encountered or expected in an accumulation is very important. It affects the field development strategy, well pattern, production techniques, reservoir management, drilling, and workover. These issues are solved taking into account hydrogeologic conditions not just in a single accumulation but in the entire field. Especially important is the information about changing hydrogeologic environment in that field. The information about the pre-development hydrogeologic (hydrodynamic and hydrochemical) environment is crucial.

Hydrogeologic studies during the petroleum exploration are also very important and data for solving the aforementioned problems should be collected during this stage.

Significant issues during the exploration stage include:

- (1) the identification of independent hydrogeologic systems in the basin being studied;
- (2) hydrodynamic drives occurring in each one;
- (3) their hydrodynamic and geochemical evolution;
- (4) the identification of hydrodynamic and geochemical anomalies as indicators of cross-flows between various horizons;
- (5) the distribution of the normalized pressure within the identified hydrogeologic stages, in the section and laterally;
- (6) the identification of locations for possible hydrocarbon traps and patterns in their distribution; and
- (7) analyzing the concepts of hydrocarbon migration in the basin and the formation and destruction of hydrocarbon accumulations.

As previously mentioned, the saturation pressure (elastic pressure) is an important exploration indicator of gas fields. If the gas-saturation pressure is close to the reservoir pressure, any uplifted area of the reservoir may be gas-bearing.

Chapter 5

CRUDE OILS

5.1. COMPOSITION OF CRUDE OILS¹⁰

Crude oil is a natural multicomponent mixture. Its major part is composed of hydrocarbons (alkanes, naphthenes, and aromatics). Their content in oils ranges between 30% and 100%. Most important among the non-hydrocarbon components are resins and asphaltenes. The other non-hydrocarbon compounds are metal-porphyrin complexes and trace elements; their content is usually low. Some compounds in oils lost structural features of the parent organic matter, whereas some other molecules preserved these features. They are called “relic hydrocarbons” or “chemical fossils”.

Alkane hydrocarbons (C_5 – C_{40}) include normal and branched molecules (isoprenoids). Carbon number distribution in the normal alkanes reflects the composition of the original organic matter. For example, lipids of the continental biomass are dominated by normal C_{25} – C_{33} alkanes that consequently are inherited by the oil. The pristane/phytane ratio is used as a genetic criterion for the isoprenoids. The pristane is associated with the continental deposits, whereas the phytane is associated with the marine deposits.

Cyclic paraffins (naphthenes) include monocyclic (5–6 carbon atoms) as well as polycyclic molecules. The latter molecules may contain 1–6 rings. This feature was probably inherited from the parent organic matter (naphthene index). But most polycyclic naphthenes (such as steranes) were not present in the parent organic matter and have been formed during catagenesis (Petrov, 1984).

Arenes (aromatic hydrocarbons) are usually not as important as the other classes of hydrocarbons in crude oils. Aromatic compounds may include exclusively aromatic rings, or may contain complex structures with naphthene rings. Some arenes are directly related to the parent organic matter.

Polishchuk and Yashchenko (2003) showed that there are cyclic changes in the chemical properties of oils (contents of paraffin, asphaltenes, resins, and sulfur) with geologic age of rocks. This cyclicity is controlled by the cyclicity of ocean transgressions and processes of formation and development of paleo-oceans in the geological history of the Earth.

Recently developed equipment and techniques drastically increased the information on oil composition. The researchers are now able to determine not only the group hydrocarbon composition, but also the composition of individual hydrocarbons and their structure. The new techniques include gas and liquid chromatography, spectral and isotope methods, and nuclear magnetic and paramagnetic resonances. Among the new highly sensitive equipment are chromatographs,

¹⁰After T.A. Botneva (in: Eremenko and Chilingar, 1996).

chromato-mass spectrometers, and infrared, ultraviolet, quasi-linear, and isotope spectrometers.

A heightened interest in the molecular- and atomic-level information on the oil composition was caused by two factors: technological and geochemical.

Petroleum hydrocarbons currently serve as a source of wide spectrum of synthetic substances used for the manufacturing of various goods in food industry and other industries. This required detailed studies of the composition of individual hydrocarbons. The current technology provides an opportunity to obtain information on the detailed composition and structure of hydrocarbons found in the high-boiling oil fractions. Such information covers carbon atom distribution in the paraffin chains and in the naphthene and aromatic rings. Lately, this information also became insufficient.

The emergence of such analytical techniques as the gas-liquid chromatography and chromato-mass spectrometry enabled scientists to

- (1) obtain new information on the composition and structure of petroleum hydrocarbons,
- (2) study in detail their homological series, and
- (3) determine the distribution patterns of normal and branched alkanes, methyl-alkanes, and isoprenoid alkanes in oils.

In studying naphthenes, new techniques led to the elucidation of the proportions of mono-, bi-, tri-, and tetracyclic naphthenes, steranes and tri-terpanes (hopanes).

Detailed studies of aromatic hydrocarbons in crude oils (using various techniques including spectral) resulted in the establishment of the presence and proportions of not only mono-, bi-, and tricyclic, but also polycyclic (4-6 cycles) hydrocarbons that were almost impossible to identify earlier. The latter include hydrocarbons such as perylene, 1,12-benzoperylene, 3,4-benzopyrene and their homologes.

Nuclear-magnetic and paramagnetic resonance techniques developed in the 1950s enabled to study the properties of nuclei in different states. This is important in studying the free radicals (kinetically independent), atoms and atom groups, and chain reactions (polymerization, pyrolysis) in biochemical processes, in which the free radicals actively participate.

A new approach in studying the crude oil hydrocarbons involves the stereochemistry of saturated aliphatic and alicyclic hydrocarbons.

Stereochemical studies of the normal and branched alkanes and mono-, bi-, tri-, and tetracyclic hydrocarbons (including hopanes) are becoming more important in geochemical studies. It was shown that the transformations (aging) of biomolecules in the Earth's crust is closely related to the changes in their stereochemistry (Petrov, 1984).

There is an increase in the trace element studies. Contents of the trace elements in crude oils vary significantly. Most of the iron series elements are found in crude oils in amounts below the clarke amounts (sedimentary rock clarke). Some elements (zinc, nickel, copper, arsenic, and silver) are found in near-clarke amounts, and four elements (vanadium, molybdenum, bromine, and mercury) are present in the amounts an order of magnitude above the clarke. This offers an opportunity of their recovery directly from crude oils. The recovery of trace elements from crude oils is

technically complex and had not been commonly used, although scientific experimentation is in progress.

On the basis of the extensive knowledge of composition and structure for all classes of hydrocarbons, the presence of biomarkers directly related to the parent biomass had been established. Genetic relationship of crude oils and parent organic matter, genetic uniformity (or nonuniformity) of oils in different stratigraphic sequences have been established. Transformations of the specific hydrocarbons within the catagenetic, weathering, etc. zones had been elucidated. This information is important in the petroleum exploration as it enables to (1) forecast the type and composition of hydrocarbon fluids, (2) identify the potential cross-flow zones, and (3) determine the paths of lateral and vertical migration.

5.2. CLASSIFICATION OF CRUDE OILS

Many methods of classification of crude oils have been devised. Systems based on a superficial inspection involving some physical property, such as specific gravity, are easily applied and specific gravity is actually used to a large extent in expressing the quality of crude oils.

Specific weight (or specific gravity) of liquids are compared to that of fresh water (Table 5.1). For example, if a brine is 1.04 times heavier than fresh water, its specific gravity is 1.04 and the pressure gradient is equal to 0.45 psi/ft ($= 1.04 \times 0.434$). The relationship between the pressure gradient and salt content in water is presented in Fig. 5.1. If the API gravity of the oil is given, its specific gravity (SG) at 60°F can be determined as follows:

$$SG = 141.5 / (131.5 + ^\circ\text{API})$$

For example, the specific gravity of oil at 37°API is equal to

$$SG = 141.5 / (131.5 + 37) = 0.84.$$

A more rational basis of classification is found in some expression of the composition of the oils. In American practice, crude oils long have been roughly classified as (a) paraffin base, (b) naphthenic or asphaltic base, and (c) mixed base if they contain both paraffin and asphalt. (Fig. 5.2). This system was derived on the basis of differences in the nature of the lubricating oil portion of the crude after a non-destructive distillation. In other words, the crude oil is carefully distilled and the portion boiling in the lubricating oil range is examined. If this portion is waxy and has the physical properties of paraffins, the crude oil is termed paraffin base. On the other hand, if the lubricating oil portion contains little or no wax and contains asphaltic material, the crude oil is termed asphaltic. Crude oils, lubricating oil fraction of which contains both paraffins and asphalts, are termed mixed base.

Using this basis for the classification of petroleum, it has been found that crude oil occurring in various sections of the United States can also be classified. The Pennsylvania type of crude oil is paraffinic. This type of crude oil is found in the eastern states of USA: Pennsylvania, West Virginia, New York, Michigan, and Ohio.

TABLE 5.1

Fluid weight conversion table (modified after Zaba and Doherty, 1956)

Gravity ($^{\circ}$ API)	Specific gravity or (g/cm^3)	Specific weight			Fluid head		Buoyancy factor (totally immersed)
		(lb/gal)	(lb/cu. ft)	(lb/bbl)	Pressure (lb/sq. in/ft)	Height (ft/lb)	
60.0	0.739	6.16	46.1	259.0	0.320	3.13	0.906
59.0	0.743	6.20	46.4	260.0	0.322	3.11	0.905
58.0	0.747	6.23	46.6	262.0	0.324	3.09	0.905
57.0	0.751	6.26	46.8	263.0	0.325	3.08	0.904
56.0	0.755	6.30	47.1	265.0	0.327	3.06	0.904
55.0	0.759	6.33	47.4	266.0	0.329	3.04	0.903
54.0	0.763	6.36	47.6	267.0	0.330	3.03	0.903
53.0	0.767	6.40	47.9	269.0	0.332	3.01	0.902
52.0	0.771	6.43	48.1	270.0	0.334	2.99	0.902
51.0	0.775	6.46	48.3	271.0	0.336	2.98	0.901
50.0	0.780	6.51	48.7	273.0	0.338	2.96	0.901
49.0	0.784	6.54	48.9	275.0	0.340	2.94	0.900
48.0	0.788	6.57	49.2	276.0	0.341	2.93	0.900
47.0	0.793	6.61	49.5	278.0	0.343	2.92	0.899
46.0	0.797	6.63	49.8	279.0	0.345	2.90	0.898
45.0	0.802	6.69	50.0	281.0	0.348	2.88	0.898
44.0	0.806	6.72	50.3	282.0	0.349	2.87	0.897
43.0	0.811	6.76	50.6	284.0	0.351	2.85	0.897
42.0	0.816	6.81	50.9	286.0	0.354	2.82	0.896
41.0	0.820	6.84	51.2	287.0	0.355	2.81	0.896
40.0	0.825	6.88	51.5	289.0	0.357	2.80	0.895
39.0	0.830	6.92	51.8	291.0	0.359	2.79	0.894
38.0	0.835	6.96	52.1	292.0	0.362	2.76	0.894
37.0	0.840	7.01	52.4	294.0	0.364	2.75	0.893
36.0	0.845	7.05	52.7	296.0	0.366	2.73	0.892
35.0	0.850	7.09	53.0	298.0	0.368	2.72	0.892
34.0	0.855	7.13	53.3	299.0	0.370	2.70	0.891
33.0	0.860	7.17	53.6	301.0	0.372	2.69	0.891
32.0	0.865	7.21	53.9	303.0	0.375	2.67	0.890
31.0	0.871	7.26	54.3	305.0	0.377	2.65	0.889
30.0	0.876	7.31	54.7	307.0	0.380	2.63	0.889
29.0	0.882	7.36	55.1	309.0	0.382	2.62	0.887
28.0	0.887	7.40	55.4	311.0	0.384	2.60	0.887
27.0	0.893	7.45	55.7	313.0	0.387	2.58	0.886
26.0	0.898	7.49	56.0	315.0	0.389	2.57	0.886
25.0	0.904	7.54	56.4	317.0	0.392	2.55	0.885
24.0	0.910	7.59	56.8	319.0	0.394	2.54	0.884
23.0	0.916	7.64	57.2	321.0	0.397	2.52	0.883
22.0	0.922	7.69	57.5	323.0	0.399	2.51	0.883
21.0	0.928	7.74	57.9	325.0	0.402	2.49	0.882
20.0	0.934	7.79	58.3	327.0	0.405	2.47	0.881
19.0	0.940	7.84	58.7	329.0	0.407	2.46	0.880
18.0	0.946	7.89	59.0	331.0	0.410	2.44	0.879
17.0	0.953	7.95	59.5	334.0	0.413	2.42	0.879
16.0	0.959	8.00	59.8	336.0	0.416	2.40	0.878
15.0	0.966	8.06	60.3	339.0	0.419	2.39	0.877

Table 5.1 (continued)

Gravity (°API)	Specific gravity or (g/cm ³)	Specific weight			Fluid head		Buoyancy factor (totally immersed)
		(lb/gal)	(lb/cu. ft)	(lb/bbl)	Pressure (lb/sq. in/ft)	Height (ft/lb)	
14.0	0.973	8.11	60.7	341.0	0.421	2.38	0.876
13.0	0.979	8.16	61.0	343.0	0.424	2.36	0.875
12.0	0.986	8.22	61.5	345.0	0.427	2.34	0.874
11.0	0.993	8.28	61.9	348.0	0.430	2.33	0.874
10.0	1.00	8.34	62.4	350.0	0.433	2.31	0.873
Pure water	1.00	8.34	62.4	350.0	0.433	2.31	0.873
	1.01	8.4	62.8	353.0	0.436	2.29	0.872
	1.03	8.6	64.3	361.0	0.447	2.24	0.869
	1.06	8.8	65.8	370.0	0.457	2.19	0.866
	1.08	9.0	67.3	378.0	0.468	2.14	0.862
	1.10	9.2	68.8	386.0	0.478	2.09	0.860
	1.13	9.4	70.3	395.0	0.488	2.05	0.856
1.15	9.6	71.8	403.0	0.499	2.00	0.853	
Salt water	1.154	9.625	72.0	404.0	0.500	2.00	0.853
	1.18	9.8	73.3	412.0	0.509	1.96	0.850
	1.20	10.0	74.8	420.0	0.519	1.93	0.847
	1.22	10.2	76.3	428.0	0.530	1.89	0.844
	1.25	10.4	77.8	437.0	0.540	1.85	0.841
	1.27	10.6	79.3	445.0	0.551	1.81	0.838
	1.29	10.8	80.8	454.0	0.561	1.78	0.835
	1.32	11.0	82.3	462.0	0.571	1.75	0.832
	1.34	11.2	83.8	470.0	0.582	1.72	0.829
	1.37	11.4	85.3	479.0	0.592	1.69	0.826
	1.39	11.6	86.8	487.0	0.603	1.66	0.823
	1.41	11.8	88.3	496.0	0.613	1.63	0.820
	1.44	12.0	89.8	504.0	0.623	1.61	0.817
	1.46	12.2	91.3	512.0	0.634	1.58	0.814
	1.49	12.4	92.8	521.0	0.644	1.55	0.810
	1.51	12.6	94.3	529.0	0.655	1.53	0.808
	1.53	12.8	95.8	538.0	0.665	1.50	0.804
	1.56	13.0	97.3	546.0	0.675	1.48	0.801
	1.58	13.2	98.7	554.0	0.686	1.46	0.798
	1.61	13.4	100.0	563.0	0.696	1.44	0.795
1.63	13.6	102.0	571.0	0.706	1.42	0.792	
1.65	13.8	103.0	580.0	0.717	1.39	0.789	
1.68	14.0	105.0	588.0	0.727	1.38	0.786	
1.70	14.2	106.0	596.0	0.738	1.36	0.783	
1.73	14.4	108.0	605.0	0.748	1.34	0.780	
1.75	14.6	109.0	613.0	0.758	1.32	0.777	
1.77	14.8	111.0	622.0	0.769	1.30	0.774	
1.80	15.0	112.0	630.0	0.779	1.28	0.771	
1.82	15.2	114.0	638.0	0.790	1.27	0.768	
1.85	15.4	115.0	647.0	0.800	1.25	0.765	
1.87	15.6	117.0	655.0	0.810	1.23	0.762	
1.89	15.8	118.0	664.0	0.821	1.22	0.759	

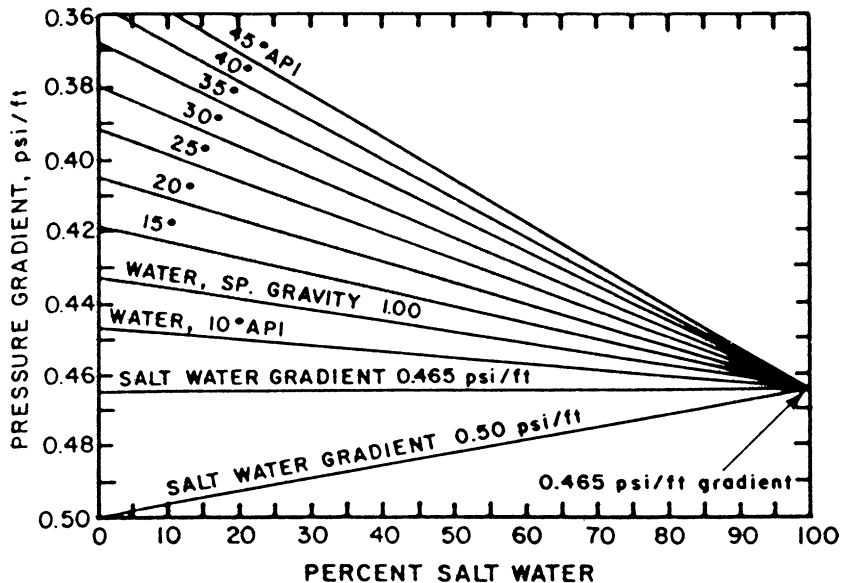

Fig. 5.1. Relationship between pressure gradient and percent of salt water in water–oil mixture (after Trash and Brown, 1965, p. 8, chart 1). If $SG = 1.07$, then the pressure gradient = $1.07 \times 0.434 = 0.465$. Pressure gradient of oil + salt water mixture = $[(\% \text{ salt water}/100) \times (\text{water gradient})] + [(\% \text{ oil}/100) \times (\text{oil gradient})]$. For example, in the case of 50:50 oil–water mixture, if oil is 42°API (0.354 psi/ft pressure gradient) and specific gravity of water is 1.07 (0.465 psi/ft pressure gradient), then the pressure gradient of a mixture = $(0.50)(0.354) + (0.50)(0.465) = 0.41 \text{ psi/ft}$.

Midcontinent type of crude oil is mixed base and is found in Kansas, Oklahoma, all of Texas except the Gulf Coast area, northern Louisiana, and Arkansas. It includes also eastern Colorado, parts of New Mexico, and Arizona.

The Gulf Coast type of crude is asphaltic and naphthenic in nature and is found in the area lying in southern Louisiana and southern Texas.

Tissot and Welte (1978) classification of crude oils is presented in Fig. 5.3.

Botneva (1987, in: Eremenko and Chilingar, 1996, p. 62, 65) studied more than 400 crude oil samples in Russia and identified nine types. Six of these have been subdivided according to their gasoline fraction composition and three, devoid of these fraction, by the paraffin/naphthene and naphthene/aromatic ratios. The following chemical types (on the basis of paraffin/naphthene ratio) were identified:

- Type I. Paraffin (paraffin/naphthene ratio > 1).
- Type II. Paraffin-naphthene (paraffin/naphthene ratio of $0.99\text{--}0.7$).
- Type III. Naphthene-paraffin (paraffin/naphthene ratio of $0.69\text{--}0.5$).
- Type IV. Naphthene-paraffin-aromatic (paraffin/naphthene ratio of $0.49\text{--}0.41$).
- Type V. Naphthene-aromatic (paraffin/naphthene ratio of $0.4\text{--}0.3$).
- Type VI. Naphthene (paraffin/naphthene ratio of < 0.3).
- Type VII. Dominance of paraffin-naphthene hydrocarbons (paraffin-naphthene/naphthene-aromatic (PN/NA) > 2).

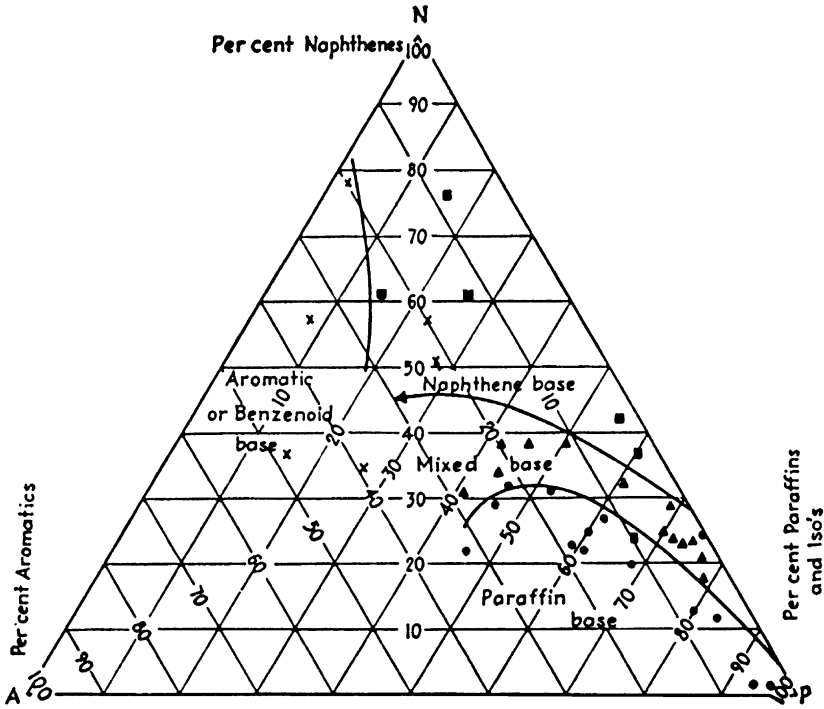

Fig. 5.2. Chemical composition of some crude oils plotted on a triangular diagram (after Nelson, 1949, Fig. 7, p. 87).

- Type VIII. A near-equal contents of paraffin-naphthene and naphthene-aromatic hydrocarbons ($PN/NA = 1$).
- Type IX. Dominance of naphthene-aromatic hydrocarbons ($PN/NA < 1$).

Oils belonging to types VII–IX are devoid of gasoline fraction.

The distribution of the above-described crude oil types by density and sulfur content is presented in Tables 5.2 and 5.3. The most commonly occurring in nature are type I crude oils, whereas the least common are types IV and IX (Table 5.4).

A number of classifications based on the identification of chemical types first on the contents of normal alkanes and isoprenoids, and then on the cycloalkanes and arenes (Petrov, 1984). Petrov subdivided all crude oils into two categories (A and B), with two subtypes within each of them (Table 5.5).

Recent developments in the petroleum geochemistry resulted in the introduction of genetic and geochemical classifications. Both classifications provide useful information for the petroleum potential forecast. Geochemistry plays an important role in forecasting the quality of crude oil in the accumulation. The information important during the field development includes the possible communication between the productive formations, oil cross-flows, possible crude alterations at the oil/water contact, etc.

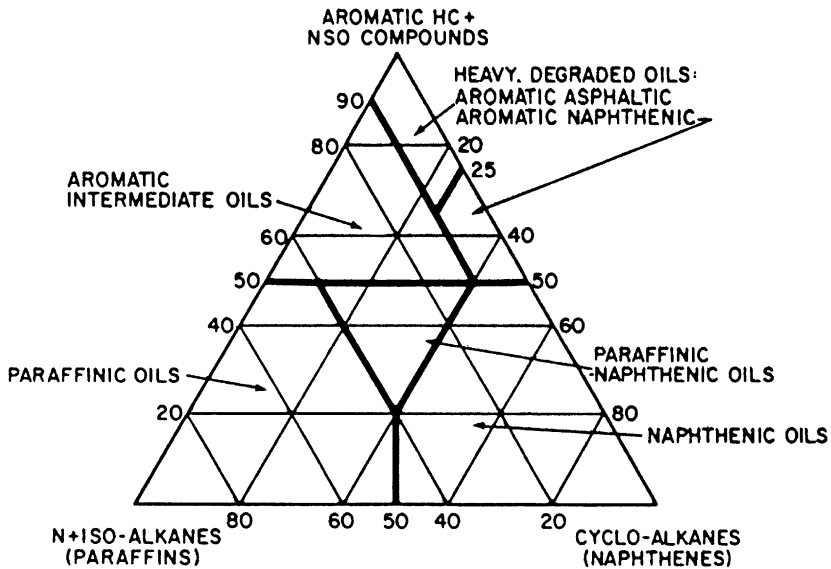

Fig. 5.3. Ternary diagram showing the composition of six classes of crude oils from 541 oil fields (after Tissot and Welte, 1978, p. 373).

TABLE 5.2

Distribution of crude oil types by density (after T.A. Botneva, in: Eremenko and Chilingar, 1996, p. 66)

Crude oil (density in g/cm^3)	Type of oil (in %)								
	I	II	III	IV	V	VI	VII	VIII	IX
Light (0.850)	70.9	69.5	60.0	36.8	18.7	18.7	7.7	2.7	12.5
Medium (0.851–0.870)	19.3	18.2	21.5	42.1	37.5	21.8	—	2.7	—
Heavy (0.871–0.900)	5.9	7.5	15.3	21.1	37.5	37.7	41.0	—	12.5
Very heavy (>0.900)	3.9	4.8	3.2	—	6.3	21.4	51.3	54.3	75.6

TABLE 5.3

Distribution of sulfur content in various types of crude oil (after T.A. Botneva, in: Eremenko and Chilingar 1996, p. 66)

Crude oil (sulfur content in %)	Type of oil (in %)								
	I	II	III	IV	V	VI	VII	VIII	IX
Low-sulfur oils (<0.5)	59.7	60	78.7	60	76.4	72.2	43.7	40.0	16.6
Medium-sulfur oils (0.5–2.0)	39.1	36	18.1	40	33.6	37.6	56.3	56.0	33.6
High-sulfur oils (>2)	1.2	4	3.2	—	—	—	—	—	49.8

TABLE 5.4

Frequency of occurrence (% of total samples analyzed) of various crude oil types (after Botneva, 1987)

Chemical type	%	Chemical type	%
I	39.7	VI	6.1
II	16.4	VII	7.4
III	12.4	VIII	6.8
IV	3.6	IX	1.5
V	6.1		

TABLE 5.5

Content of various hydrocarbons in 200–430°C boiling fraction (after Petrov, 1984)

Hydrocarbons	Content in oils of different types (%)			
	A ₁	A ₂	B ₁	B ₂
Alkanes	15–60 (25–50)	10–30 (15–25)	5–30 (10–25)	4–40 (6–10)
<i>n</i> -Alkanes	5–25 (8–12)	0.5–5 (1–3)	0.5	Not found
Isoprenoids	0.05–6 (0.5–3)	1–6 (1.5–3)	0.5–6 (0.2–2)	Not found
Cycloalkanes	15045 (25–40)	20–60 (35–55)	20–70 (35–55)	20–70 (50–65)
Arenes	10–70 (20–40)	15–70 (20–40)	20–80 (20–45)	25–80 (25–50)

Note: Most commonly encountered values are in parentheses.

Problems associated with the petroleum forecasting may not be solved, unless the genetic uniformity/nonuniformity of the crude oils in a given field and region is determined.

In order to subdivide the crude oils into genetic types, the criteria for the identification of genetic types have been developed. The genetic indicators in crude oils are associated with the organic matter composition of the source rocks. There is some disagreement among petroleum geologists as to what these genetic parameters are. According to one school of thought, there are just a few genetic types of crude oils. These types are the same in all petroleum provinces worldwide and are defined by the facies-genetic type of organic matter (sapropelic, humic and their combinations) and by the degree of oxidation or metamorphism of the organic matter. The other approach is that the crude oil genetic type is defined by the specific characteristics of the composition of parent organic matter and the chloroform-extractable bitumen that are specific for each source rock within each petroleum basin. It was found that changes in the biomass composition occurred in the Phanerozoic:

- (1) the number of taxons increased;
- (2) the diversity of forms grew, as well as the replacement of some forms by the others; and
- (3) changes occurred in the biochemical composition of organisms (changes were caused by the evolution of the living matter in Phanerozoic, as well as by the

difference in living environment in different basins at the same geologic time interval).

According to the proponents of the first concept, genetic types of crude oils are rigidly associated with the facies-genetic type of organic matter. For example, a marine, sapropelic type of organic matter always (at any geologic period and in any basin) generated the same genetic oil type (e.g., type A). This approach does not take into consideration the evolution of living matter. It is doubtful that the sapropelic (marine) type of organic matter was identical in the Paleozoic, Mesozoic, and Cenozoic sediments of different sedimentary basins, e.g., Siberia (platform) and Caucasus (geosyncline).

The second approach is based on the concept of multiple genetic types of crude oils and their uniqueness within each petroleum province. The contention here is that any sedimentary basin has its own specific biomass. Besides, organic matter in the source rocks of the same facies-genetic type (e.g., the sapropelic type) could, due to evolution, substantially change from one geologic time interval to the next, acquiring specific hydrocarbon composition and structure.

The identification of biomarkers that are not present in the other crude oils is of a particular genetic interest. There are certain compounds discovered only in particular crude oils (Petrov, 1984):

- (a) 1,2- and 1,3-methylalkanes, in East Siberia;
- (b) the biotriocoxan, in Indonesian crude oils;
- (c) the C₂₅ hopane, in a Siberian crude oil;
- (d) the dyno-methyl-adiantanes, in North Sea crude oils;
- (e) the cyclic isoprenoids with an irregular structure and trimethyl-alkyl-cyclohexanes with an isoprenoid chain, in the Buzachi Peninsula (North Caspian, Kazakhstan) crude oils; and
- (f) the hopane-type six-cyclic monoaromatic hydrocarbons, in the inter-salt Pripyat deposits (Belarus).

The genetic classification of crude oils of T. A. Botneva and N. A. Eremenko is based on several concepts. These include (a) each oil/gas source rock in a given petroleum province generates a specific type of oil; (b) the set of genetic types is rather limited and changeable; and (c) the set of genetic criteria may change in different petroleum provinces. In some cases, the crude oils belonging to different genetic types may be different in the structure of their paraffins. In some other cases, the difference may be in

- (1) naphthene index,
- (2) mono- or polycyclic aromatics,
- (3) the metal and its content in the porphyrin complexes,
- (4) the pristane/phytane ratio (or the other isoprenoids), and
- (5) the composition of light gasoline fraction (C₅+C₆/C₇+C₈; cyclohexane/cyclopentane; toluene/benzene, etc.; see Chakhmakhchev, 1982).

The genetic type of crude oil is indicative of the initial properties of the fluid, its homologous series of hydrocarbons, and the configuration of carbon atoms; however, the crude oil composition, as determined in the laboratory, is a result of its long evolution in the Earth's crust. Depending on the geologic/geochemical scenario,

crude oil in the accumulation may be affected by various secondary factors, such as catagenesis, hypergenesis, and migration. These factors may change the crude oil composition. Determination of the trend and the scale of these changes and their controlling factors may be very important for the development of hydrocarbon accumulations and for the forecast of their chemical composition. The effect of secondary (i.e., subsequent to the formation of accumulations) factors on the crude oil composition is the basis of geochemical oil classification.

It is difficult to select the criteria, which would help to determine the role of processes controlling the changes in crude oil composition (i.e., role of catagenesis, hypergenesis, and migration). The reason for this is that some parameters changed similarly in response to different processes. For instance, an increase in the density of crude oil or content of resins may occur as a result of hypergenesis or of migration resulting in the selective adsorption. Decrease in density, decrease in the resin content, and increase in the paraffins content may be caused by catagenesis as well as by the "filtration" during migration.

The geochemical classification of crude oils includes the following types:

- Type 1. Catagenetically altered crude oils.
- Type 2. Hypergenetically altered crude oils.
- Type 3. Crude oils which underwent various alterations during migration.

The following are typical for type 1: (a) lowering of the crude oil density; (b) lowering of the content of resins plus asphaltenes; (c) simplification of complex hydrocarbon structures; (d) lowered role of high-molecular hybrid molecules; (e) lowering, sometimes to zero, of metal-porphyrin complexes; and (f) increase in the content of gasoline fraction.

Type 1 crude oils are mostly encountered in geosynclines and, only rarely, in platforms. The scope of the catagenetic effect on crude oil composition is determined by the following two factors.

The first one is related to the temperature and pressure. Catagenetic alterations of the crude oil composition are caused not just by a simple increase in the formation temperature, when the temperature exceeds the oil generation temperature in the source rock. It is believed that the maximum generation of oil occurred within the temperature interval of 60–120°C. Oil accumulations formed at a lower temperature after the hydrocarbons have migrated from the structural lows (high-temperature generation foci) to the uplifted areas (traps). In the process of the further geologic evolution an accumulation may enter into zones of higher-than-generation temperature. If the oil stays there long enough it may be subjected to the aforementioned catagenetic alterations, up to the transformation to gas-condensate mixtures. This, however, does not occur frequently.

The second factor is associated with the structural characteristics of the hydrocarbon molecules. The composition of oil from 140 accumulations has been studied by T.A. Botneva. The accumulations were selected from different petroleum provinces of Russia, Azerbaijan, and Belorussia. These accumulations were stratigraphically diverse (Pliocene, Eocene, Jurassic, and Devonian) and over 4 km in depth. No

pattern was found in the compositional changes with increasing depth and temperature. In some cases, the indications of catagenic changes (low density, high gasoline content, high content of paraffins, and low degree of paraffin cyclicality) were obvious, whereas in others they were barely noticeable or non-existent.

Infrared spectroscopy studies enables determination of the ratio of long to short paraffin chains, the degree of their branching, and the number of CH_2 and CH_3 groups. In some crude oils with catagenetic alterations, the fraction of long chains in the paraffin-naphthene crudes decreases, and of short ones, increases. This is an indication of destruction of long-chain paraffins. In another group of crude oils, exposed to the similar temperature and pressure, the number of long chains did not decrease. Possibly, the resistance to destruction of paraffins in the latter case was greater. In general, the catagenetically altered crude oils are rare.

Hypergenetic alteration affects the crude oils composition in the accumulation more profoundly. The geochemical types of hypergenetically altered crude oils include (1) oxidized, (2) biodegraded, and (3) degassed. Hypergenetic processes include (1) oxidization (on contact with oxygen); (2) bacterial reduction of sulfates; and (3) loss of the light hydrocarbon fractions. The hypergenetic alterations are more pronounced when several processes are operative (for instance, degassing plus chemical and bacterial alteration).

Hypergenetically altered oils are usually heavier (lower $^\circ\text{API}$ gravity), higher in resins and asphaltenes contents, and lower in the gasoline boiling point fraction. A very informative criterion is found on infrared spectrograms of crude oils: the presence and intensity of the 1710 cm^{-1} absorption band that reflects the content of oxygen-containing carbonyl groups. Modeling of hypergenetic processes due to oxidation, sulfate reduction, etc. showed that the crude oils that had not been subjected to hypergenesis do not have the 1710 cm^{-1} absorption band in their infrared spectrograms.

On the other hand, the crude oils that underwent hypergenetic alterations have 1710 cm^{-1} absorption band ranging from 0.01 to 0.5 and even higher. The oils with 1710 cm^{-1} absorption band within a few hundredths do not display any significant changes in their properties and composition. Such oils are usually found near the oil-water contact. The crude oils with 1710 cm^{-1} absorption band of a few tenths do display significant changes in their properties and composition. As a rule, those are heavy oils with a very low content of low boiling point fractions.

The distribution of differently hypergenetically altered crude oils is presented in Table 5.6. As shown, 86% of the very oxidized crude oils are found at depths shallower than 400 m. Most of them in Russia occur in the Cretaceous and Jurassic rocks of the North Caspian and North Caucasus-Mangyshlak petroleum provinces.

Alterations during migration result in changes in the composition of crude oils. Depending on the type of migration, these alterations may be quite significant. Some experiments (Mileshina et al., 1983) showed that the composition of crude oil flowing through rocks changes (depending on the lithology, temperature, and pressure).

Upon migration of crude oil through sands and sandstones, the number of paraffin structures increases, whereas the role of naphthene cycles declines. The degree

TABLE 5.6

Distribution of crude oils with different degree of oxidation at various depth intervals

Depth Interval (m)	Crude oil		
	No oxidation	Slightly oxidized	Strongly oxidized
300–999	12.3 (17.0)	32.2 (38.1)	86.6 (44.9)
1,000–1,999	33.7 (62.5)	21.5 (34.3)	4.6 (3.2)
2,000–2,999	29.8 (52.4)	28.7 (43.5)	5.9 (4.1)
3,000–3,999	12.9 (52.2)	13.4 (43.1)	2.9 (4.7)
4,000–4,999	9.6 (70.8)	4.6 (29.2)	Not found
5,000–5,999	1.7 (75)	0.1 (25)	Not found

Note: In parentheses: percent of crude oil samples having different degree of oxidation at a certain depth interval.

of cyclization in naphthenes decreases and the aliphaticity coefficient (C_p/C_n) drastically increases. Similar alterations in crude oils occur during the migration through carbonate rocks (e.g., microgranular limestones and dolomites). However, an increase in the density and in the contents of asphaltenes and resins, and naphthene-aromatic hydrocarbons was recorded for carbonates. These alterations may have been caused by the oxidation of naphthene hydrocarbons and by the appearance of ester groups instead of the ethyl ones in the paraffin chains. The great diversity in physical properties of rocks through which the crude oil migrates affects the nature and scale of the migration-associated alterations. The effect on the composition of crude oil as a result of migration decreases in the following order: clays → silts and sands → limestones → dolomites → anhydrite. It may be very difficult to determine the geochemical type of migration-altered oil, because many parameters may exhibit similar changes from other processes. The resins/asphaltene ratios (and other similar ones) were proposed as a criterion for the identification of migrated crude oils (this particular ratio drastically increases, up to 40%, upon migration). Mileshina et al. (1983) believe that one of the best criterion of the migrated crude oils is an increase in the degree of aliphaticity of paraffinic and aromatic hydrocarbons (and even in tars) by a factor of 1.5.

Determination of a geochemical type for the migration-altered crude oils is important in evaluating the type and direction of migration. For instance, in the differential entrapment (accumulation of oil and gas in interconnected traps), assigning the crude oil to the migration-altered type (rather than oxidized) may enable one to determine the direction of regional migration.

This page intentionally left blank

*Chapter 6***NATURAL GASES AND CONDENSATES**

6.1. COMPOSITION OF NATURAL GASES

Natural gases are a naturally occurring mixture of hydrocarbon and non-hydrocarbon gases found in porous formations beneath the Earth's surface, often in association with crude oil. Their chemical composition and physical properties are quite diverse. Most common among gaseous chemical compounds are hydrocarbons, H_2 , CO_2 , CO , N_2 , H_2S , NH_3 , O_2 , etc. On the basis of their origin, Belousov (1939) classified gases into (1) biochemical; (2) aerial; (3) associated with natural chemical reactions occurring at ambient or high temperature; and (4) radioactive. There are many other classifications, which are either highly specialized (e.g., for volcanic gases) or incorporate the above classification.

Primarily, natural gas is a mixture of hydrocarbon molecules belonging to the paraffin series. The simplest hydrocarbon is methane, CH_4 ; followed by ethane, C_2H_6 ; propane, C_3H_8 ; butane, C_4H_{10} ; and heavier components as shown in Table 6.1. These compounds have the chemical formula of C_nH_{2n+2} .

Natural gas is principally composed of methane with decreasing amounts of ethane, propane, and heavier components. It normally is partially or completely saturated with water vapor and many contain nitrogen and inert gases such as helium and argon, and acid gases such as carbon dioxide, hydrogen sulfide, and mercaptans.

In the Earth's crust, gases are mostly dissolved (in water or in oil) or sorbed, and often form free accumulations. Free gas accumulations may be formed by hydrocarbons, sometimes by nitrogen, and rarely by carbon dioxide, but usually by mixtures (in various proportions) of these gases. The other compounds are present in the form of an admixture, although sometimes a significant one (e.g., up to 20% of H_2S).

Hydrocarbon gases may contain a fraction of 1% to a few percentage points of CO_2 (sometimes its content is much higher). The CO_2 content in the South Semivodskoe gas-condensate field (West Siberia) is 73.1%, and that of the Braden South Field (U.S.) is 86.6%. The CO_2 presence is typical in the solution gases of young (Paleogene, Neogene) crude oils. Some increase in the CO_2 content is noted in the natural gases of foredeeps. Average nitrogen content in hydrocarbon gases ranges from 0.5 to 12%. The lowest nitrogen concentrations (fractions of 1%) are found in the areas of deep basement subsidence, foredeeps, and intermontane depressions. Gases on young platforms usually contain less than 5% nitrogen, and those on ancient platforms (such as Russian or American) contain 5–7%. The nitrogen content in the natural gases drastically increases in the western Volga-Ural province, where it may exceed 95%.

TABLE 6.1

Composition of natural gases

Component	Type of gas field			Natural gas separated from crude oil		
	Dry gas, Los Medanos, California (mol%)	Sour gas, Jumping Pound, Canada (mol%)	Gas-condensate, Paloma, California (mol%)	Ventura, California		
				400 lb* (mol%)	50* lb (mol%)	Vapor (mol%)
Hydrogen sulfide	0	3.3	0	0	0	0
Carbon dioxide	0	6.7	0.68	0.30	0.68	0.81
Nitrogen and air	0.8	0	0	0	0	2.16
Methane	95.8	84.0	74.55	89.57	81.81	69.08
Ethane	2.9	3.6	8.28	4.65	5.84	5.07
Propane	0.4	1.0	4.74	3.60	6.46	8.76
Isobutane	0.1	0.3	0.89	0.52	0.92	2.14
<i>n</i> -Butane	trace	0.4	1.93	0.90	2.26	5.02
Isopentane	0	0	0.75	0.19	0.50	1.42
<i>n</i> -Pentane	0	0	0.63	0.12	0.48	1.41
Hexane	0	0.7	1.25	0	0	0
Heptane	0	0	0	1.05	1.05	4.13
Octane	0	0	6.30	0	0	0
Nonane	0	0	0	0	0	0
Total	100	100	100	100	100	100

*Separator pressure in psi (pounds per square inch).

The H₂S content in the hydrocarbon gases ranges between 0 and a few percentage points. At a significant depth (deeper than 4,500 m) and in a predominantly carbonate section it may be higher than 20% (Astrakhan Field in Russia, Tengiz Field in Kazakhstan, and Emory Field in the U.S.).

Most common of the inert gases is helium. Its average concentration is 0.01–0.2% and rises to 10% on the ancient platforms. The argon content ranges from 0.001 to 0.1%, sometimes up to 1–2% in helium-rich gases.

6.2. ISOTOPE COMPOSITION OF NATURAL GASES

6.2.1. Carbon

The carbon isotope composition in hydrocarbon gases varies from 40‰ to 50‰ (and higher).

Gases form biochemically in near-surface environment from plant and animal remains. Such gases have a high methane content (90% and higher). This methane is enriched in the light carbon isotope (¹²C) compared with the carbon of organic matter (up to 50‰ and higher).

The carbon of methane in natural gases is isotopically heavier than the carbon of methane of biochemical origin, but lighter (by 10–20‰) than the carbon of crude oils. Table 6.2 shows average $\delta^{13}\text{C}$ values for the carbon in some naturally occurring compounds (see also Khilyuk et al., 2002).

There is no clear correlation between the type of organic matter and isotope composition of its carbon. There is also no correlation with the geologic age of the gas-containing deposits (except for biochemical gases where the correlation is apparently not with the geologic age but with the formation temperature). Some correlation was reported between the $\delta^{13}\text{C}$ and the present day depth of occurrence of natural gas, which may be due to the mixing of the deep gases with the near-surface ones.

6.2.2. Hydrogen

Mass-spectrometry studies failed to identify any trends in the protium/deuterium ratio in natural gases. It was established, however, that the isotope composition of

TABLE 6.2

Average $\delta^{13}\text{C}$ Values for Some Compounds (After Prasolov, 1990)

Compound	$\delta^{13}\text{C}$ (‰)	Compound	$\delta^{13}\text{C}$ (‰)
Carbonates	–0.1	Propane	–27.0
CO ₂ of the accumulations	–8.7	Ethane	–31.3
Kerogen	–25.0	Methane	–42.6
Organic matter in bitumens	–27.0	Methane (biochemical)	–75.0
Crude oil	–29.7		

both hydrogen and carbon in natural gases depends on their origin (Shen et al., 1988; see also Khilyuk et al., 2002).

6.2.3. Sulfur

Numerous studies in the former Soviet Union showed that the $\delta^{34}\text{S}$ content in natural gases ranges between 18 and 20‰. The gases in younger deposits (Neogene, Paleogene) are richer in the heavy sulfur isotopes than the sulfur in crude oils, whereas in the older (Carboniferous) gases the isotope content of gases and oils is similar or even lower in gases. This fact casts doubt on the conclusion that there is a genetic relation between the sulfur present in oil and in gas. Interesting results were obtained in the experiments on microbial reduction of sulfates. It was found that the resulting H_2S might have sulfur of different isotope composition depending on the amount and speed of the introduction of sulfates into water. When the sulfate supply is constant and high, the sulfur in the H_2S is lighter. When the rate of sulfate introduction is equal to that of its destruction, the formation water may become almost totally sulfate-free and the isotope composition of sulfur in the H_2S may be equal or slightly lower than in the introduced sulfate. Krouse et al. (1988) had found that the sulfur in the gas accumulations rich in H_2S are enriched in ^{34}S .

6.2.4. Nitrogen

Nitrogen isotope composition in the natural environments ranges between -30 and $+30$ ‰. The $\delta^{15}\text{N}$ content in the natural gases ranges from -15 to -30 ‰. Prasolov (1990) reported the following $\delta^{15}\text{N}$ variations for large tectonic units (‰):

Russian Platform	-10 (Kolliyar, C_{10}) to $+26.5$ (Orenburg, P_1)
Timan-Pechora	$+0.4$ (Dzhebed, D_3) to $+26.9$ (Vuktyl, C_1)
North Caspian Basin	$+27.8$ (Listvinskoye, P_1)
Dnieper-Don Basin	-6.5 (Rybalskoye, P_2) to $+0.4$ (Glinsko-Rozbyshev, C_1)
Siberian Platform	-5.3 (Kuimba, R) to -1.3 (Ust' Vilyuy, R)
Vilyuy Syncline	-8.6 (Middle Tyunga, P_2) to -1.8 (Mastakh, P_2)
West Siberia	-14 (Urengoi, K_1) to -3 (Kharstovey, K_1)

Considerable variations in the $\delta^{15}\text{N}$ content in natural gases are due to (1) the presence of intrinsic nitrogen in the Earth's crust and (2) fractionation (and mixing of gases with various $\delta^{15}\text{N}$ content) during migration. The latter has been established by Hoering and Moore (1958) — the $\delta^{15}\text{N}$ becomes lighter in the direction of migration.

Apparently, sedimentary rocks, which are the richest in nitrogen, serve as the major source of nitrogen. These rocks include nitrogen in their minerals and in the organic matter. Metamorphic rocks, coals, crude oils, volcanic rocks, and the atmospheric air also may have been sources of nitrogen. Compared to the associated crude oils, nitrogen in the natural gases is lighter by 3–15‰.

Mixing of nitrogen in sedimentary rocks with the nitrogen coming from the mantle is quite possible, but cannot be proved at the current level of analytical techniques. Prasolov (1990) who studied the problem mentioned that the mantle nitrogen in most cases cannot be identified against the background of the crustal and atmospheric nitrogen.

6.2.5. Inert gases

Inert gases of a predominantly radioactive origin may form in the Earth's crust as well as in the upper mantle. According to Prasolov (1990), the mantle helium is present in the natural gases of the Earth's crust. Its content is minimal (< 1%) in the gases of sediment cover. The mantle helium dominates only in gases associated with the present-day volcanism and rifting. The same writer estimated the current gas composition in the upper mantle taking into account the vapor pressure and isotopic composition:

CO_2/He	CH_4/He	N_2/He	$^{40}\text{Ar}/\text{He}$	$^{36}\text{Ar}/\text{He}$	$^3\text{He}/\text{He}$
100	10	4	1	10-4	10-5

On the basis of the above, the mantle CO_2 may be expected in gas accumulations of the sediment cover, in addition to negligible amounts of methane and other gases.

The age of the gas can be determined from the He/Ar ratio, taking into account their radioactive origin. For instance, Fig. 6.1 shows the evolution in time of the He/Ar ratio. Table 6.3 illustrates distributions of $^4\text{He}/^{40}\text{Ar}_B$ and $^{40}\text{Ar}_P/^{40}\text{Ar}_B$ in gas accumulations of tectonic units of different age.

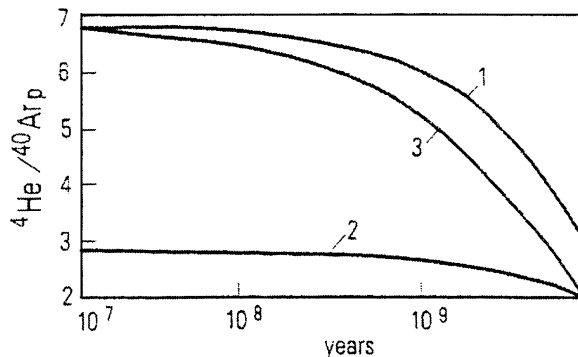

Fig. 6.1. Variation of $^4\text{He}/^{40}\text{Ar}_p$ ratio with time. 1 — In gases being formed in rocks t years ago; 2 — in gases formed between 4.5 billion years ago to time t ; 3 — in gases formed between the time t and present time. t — abscissa. (After Prasolov, 1990.)

TABLE 6.3

Distribution of ${}^4\text{He}/{}^{40}\text{Ar}_B(\text{A})$ and ${}^{40}\text{Ar}_P/{}^{40}\text{Ar}_B(\text{B})$ in Gas Accumulations (After Prasolov, 1990)

Sample	Parameter	Ratio	Sample	Parameter	Ratio
Oil and gas basins worldwide	A	$\frac{10}{8.5-12}$	Young platforms	A	$\frac{7}{5-9}$
	B	$\frac{0.65}{0.6-0.75}$		B	$\frac{0.06}{0.45-0.75}$
Ancient platforms	A	$\frac{16}{12-21}$	Folded regions	A	$\frac{1.1}{0.8-1.6}$
	B	$\frac{1.0}{0.7-1.3}$		B	$\frac{0.23}{0.16-0.32}$

Note: Denominator shows variance range with confidence probability of 0.95

6.3. PHYSICAL PROPERTIES OF NATURAL GASES

6.3.1. Gas density

Gas density (ρ in kg/m^3 , g/cm^3 , $\text{lb}/\text{cu ft}$) is a mass m of a unit volume of gas V or the ratio of the gas molecular mass M to the volume of a mole:

$$\rho = m/V \quad (6.1)$$

or

$$\rho = M/22.4 \quad (6.2)$$

Molecular mass of a substance (a non-dimensional value) is the ratio of the mass of a substance's molecule to 1/12th of the mass of the ${}^{12}\text{C}$ -isotope atom mass. The amount of a substance equal to its molecular mass expressed in grams is called gram-mole. The density of a gas mixture is determined from the density of the mixture components taken under identical conditions:

$$\rho_{\text{mix}} = \sum \rho_i n_i \quad (6.3)$$

where ρ_{mix} and n_i are the density and molar fraction of the i th component in the gas mixture.

Specific weight γ of a gas is the weight of 1 cu m (kg/m^3) or 1 L (g/l) of the gas at 0°C and 1 atm:

$$\gamma = \rho g \quad (6.4)$$

where g is the gravitational acceleration.

Gas density is determined by its chemical composition (proportions of various components), molecular weight of its components, pressure, and temperature. As temperature increases, the gas density decreases. As the molecular mass and pressure increase, the gas density grows. Sometimes, the specific gravity of a natural gas is

used: a dimensionless value equal to the ratio of gas density to the air density. The air density under standard conditions is 1.293 kg/m^3 .

Although many authors believe that the buoyancy forces (Archimedes principle) are the main cause of gas movements and distribution in the accumulations, other forces also cause fluid movements in the reservoir rocks. Pressure in the gas portion of an accumulation is higher than in a similar water-filled trap by the amount of the surplus pressure, which is equal to

$$P_{\text{surplus}} = (\rho_w - \rho_g)gH \quad (6.5)$$

where ρ_w is the water (or oil) density, ρ_g the gas density, g the gravitational acceleration, and H the height of accumulation column. For precise calculations, one must take into account changes in the gas density depending on the height of accumulation column and the gas composition.

As the above equation shows, the surplus pressure is proportional to the density difference and the height of accumulation column. The surplus pressure should not be confused with abnormal, or abnormally-high formation pressure (AHFP). The reasons for their emergence and existence are different. The surplus pressure is caused by the existence of the accumulation with fluids of different density. On the other hand, AHFP is an expression of the elastic energy accumulated in a limited volume; its existence is defined by the relaxation conditions and is not associated with the presence or absence of a hydrocarbon accumulation. Strictly speaking, when determining AHFP, the surplus pressure should be subtracted although it is usually impractical.

6.3.2. Combustion heating value

The heat-generating capacity is the amount of heat (e.g., in joules) that is released during the total combustion of a unit volume (e.g., 1 m^3) of a natural gas. Part of the combustion heat is expended to evaporate the water contained in the flue gas and the water contained in the gas itself (if any). Thus, the uppermost (gross) Q_{up} and lowermost (net) Q_{low} heating values are distinguished. The difference is the latent heat of vaporization of water vapor in the flue gas. The hydrocarbon heat-generating capacity grows as the molecular weight increases.

6.3.3. Compressibility of natural gases

Compressibility takes into account the deviation of the behavior of natural gases from that of ideal gases. In estimating gas reserves it is important to compare the gas volumes at reservoir conditions to those at standard conditions. Theoretically, the van der Waals' equation may be used for the natural gases:

$$(p + a/V^2)(V - b) = RT \quad (6.6)$$

where p is the pressure in MPa, T and V are the absolute temperature ($^{\circ}\text{C}$) and the volume (cm^3) of 1 g-mol of the gas, respectively, and R is the gas constant (8.32 J/mol T). The a/V^2 value ("internal pressure") accounts for the mutual attraction of molecules, and b is the volume of molecules.

In practice, however, the Clapeyron equation with the compressibility factor Z (due to intermolecular attraction) is used:

$$pV = ZmRT \quad (6.7)$$

where m is the mass of gas, R = the gas constant, T = the absolute temperature, and Z = the compressibility of the natural gas (which is a function of pressure, temperature, and gas composition). For ideal gases, $Z = 1$. The compressibility of a gas mixture may be computed as a weighted average of compressibility of all components.

6.3.4. Deviation of pressure at bottom of gas column

If point 2 (in a gas column) lies at distance ΔL below point 1 (p_1 in psi), the pressure at point 2 (p_2 in psi) is equal to

$$p_2 = p_1 + (\gamma \Delta L)/144 \quad (6.8)$$

where γ is the specific weight of gas in lb/cu ft.

On using the equation of state and considering 1 lb of gas,

$$pv = ZNRT \quad (6.9)$$

where p is the absolute pressure in lb/sq ft, v = the specific volume in cuft/lb, Z = the compressibility factor, N = the number of moles of gas, R = the universal gas constant, and T = the absolute temperature in °R.

Thus,

$$v = ZNRT/p \quad (6.10)$$

In as much as

$$v = 1/\gamma \quad (6.11)$$

and

$$\gamma = p/ZNRT \quad (6.12)$$

On substituting Eq. 6.12 into Eq. 6.8,

$$p_2 = p_1 + (p/144ZNRT)\Delta L \quad (6.13)$$

Rearranging,

$$p_2 - p_1 = (p/144ZNRT)\Delta L \quad (6.14)$$

and

$$dp/p = dL/144ZNRT \quad (6.15)$$

In integral form, Eq. 6.15 becomes

$$\int_{p_s}^{p_{bc}} dp/p = \int_0^L (1/144ZNRT) dL \quad (6.16)$$

Thus,

$$\ln(p_{bc}/p_s) = L/144Z_{av}NRT_{av} \quad (6.17)$$

and

$$p_{bc}/p_s = \exp(L/144Z_{av}NRT_{av}) \quad (6.18)$$

or

$$p_{bc} = p_s \exp(L/144Z_{av}NRT_{av}) \quad (6.19)$$

where Z_{av} is the average compressibility factor computed at T_{av} and p_{av} , N is the number of moles of gas, R the universal gas constant, which is equal to 10.7 for 1 lb. mol of gas, p_s is the pressure at surface in psia, p_{bc} is the pressure at bottom of gas column in psia, L is the length of gas column in ft, and T_{av} the average temperature in gas column in °R.

On simplifying the exponent and considering 1 lb of gas,

$$p_{bc} = p_s \exp(LG_g/53.3Z_{av}T_{av}) \quad (6.20)$$

where G_g is the gravity of gas as compared to that of air ($SG_{air} = 1$).

The average temperature in the gas column can be computed from the following equation:

$$T_{av} = T_s + (D/2)(dT/dL) + 460^\circ \quad (6.21)$$

where T_s is the temperature at the surface in °F, D is the vertical length of gas column in ft, and dT/dL is geothermal gradient, which is around 2°F/100 ft. Geothermal gradient, however, varies with locality.

6.3.5. Gas viscosity

Gas viscosity increases with temperature. The reason is the increase in speed of molecules and in the number of their collisions. If, however, the pressure also increases, the gas viscosity stops increasing and then even declines at pressures specific for each gas. At high pressures, viscosity of the natural gas increases with increasing molecular weight. At the same pressure and temperature, the hydrocarbon gases possess lower viscosity than the non-hydrocarbon gases. The viscosity of hydrocarbon gases increases with increasing pressure at the same temperature (100°C) as shown in Fig. 6.2. In the presence of N₂, CO₂, and H₂S, the viscosity of hydrocarbon gases slightly increases.

6.3.6. Hydrate formation

At certain pressure and temperature, hydrocarbon gases combine with water, forming crystalline hydrates. Crystalline hydrates are solid solution of gas in water. Water molecules form a 3D frame invaded by very mobile gas molecules. Only light hydrocarbons through pentane are capable of forming gas hydrates. The following empirical formulae were established for the gas hydrates: methane, CH₄ · 7H₂O; ethane, C₂H₆ · 8H₂O; propane, C₃H₈ · 18H₂O. Critical hydrate-formation temperature for methane is 21.5°C; for ethane, 14.5°C; for propane, 5.5°C; for *i*-butane, 2.5°C; and for *n*-butane, 1°C. The heavier the hydrocarbon gas, the easier it forms

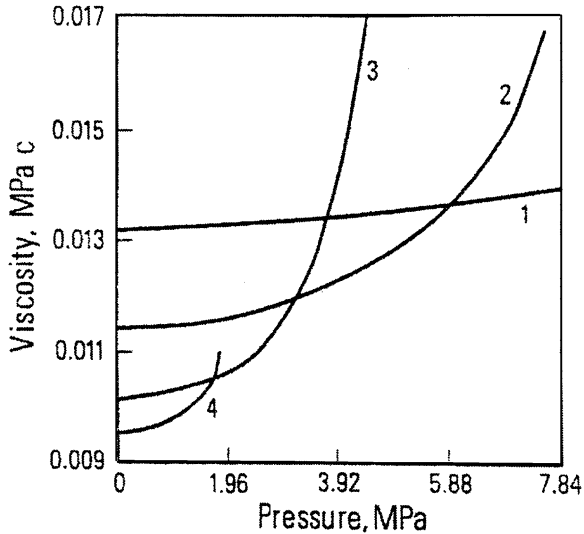

Fig. 6.2. Relationship between viscosity and pressure for some hydrocarbon gases (at 100°C). 1 — Methane; 2 — ethane; 3 — propane; 4 — *n*-butane. (After T.A. Botnieva, in: Eremenko and Chilingar, 1996, p. 76.)

the crystalline hydrate. At a given temperature and pressure, a unit volume of hydrate contains several times more gas than in the case of free gas. When the conditions are favorable, gas hydrates form accumulations in the Earth's crust. A gas-hydrate accumulation is present in the Arctic West Siberia. The proof of this accumulation is indirect, because of discrepancy between the trap volume and the amount of produced gas. Of course, there is a possibility of communication through a fault between this accumulation and a deeper, large gas accumulation.

The only favorable environment for the formation of gas-hydrate accumulations on land is the permafrost environment. Rather favorable conditions are encountered in the marine deposits. For instance, gas hydrates were discovered in the Caspian Sea deposits (L. Lebedev, in: Eremenko and Chilingar, 1996, p. 79). There are widespread occurrence of gas hydrates in the oceans (such as near the eastern coast of New Zealand).

6.3.7. Solubility of gases in water

At temperatures and pressures substantially below the critical, the hydrocarbon gas solubility in water roughly obeys the Henry's law. An increase in water salinity results in a decrease in hydrocarbon gas solubility, whereas the saturation of water with gases leads to a decrease in solubility of liquid hydrocarbons.

Colloidal solubility of hydrocarbons in water can be one or two orders of magnitude higher than the molecular solubility. For the former to occur, however, the critical concentration for the micelle-formation must be reached, which is unusual in natural environments. As the concentration of surfactants in a solution increases, so

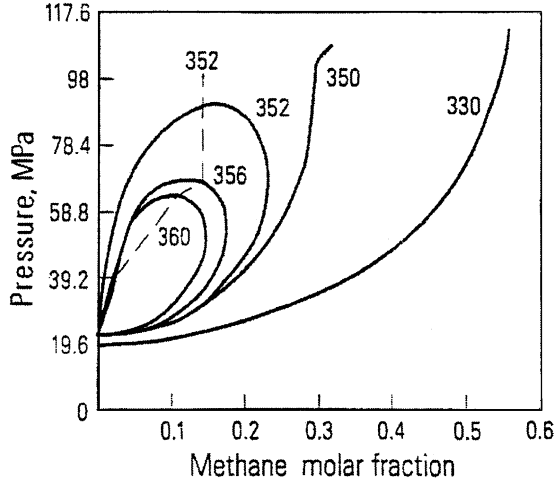

Fig. 6.3. Relationship between pressure and methane content in gas-water and methane-water systems (Sultanov, Skripka, Namiot, personal communication, 1971. In: Eremenko and Chilingar, 1996, p. 80.). Dashed line connects critical points. Numbers are temperatures in °C.

does the solubility of hydrocarbons. The presence of CO_2 increases the hydrocarbon solubility in water and in gases.

Water solubility in hydrocarbon gases at low pressure (<15–20 MPa) and at temperatures below 50°C is insignificant — just decagrams per cubic meter. The situation substantially changes in the presence of compressed gases. The content of water in a compressed gas slightly increases with increasing pressure and drastically increases with increasing temperature. A phase diagram of the methane–water system (see Fig. 6.3) shows that at 300°C and a pressure below 340 MPa, the liquid–gas boundary curves do not become closer. At 352°C the methane–water system has a double critical point.

At the same temperature and pressure, mixtures of methane and its homologs contain less water than the pure methane. With increasing molecular weight of hydrocarbons, the water content in the gas phase decreases somewhat. The result is the same if the water contains salts.

6.3.8. Solubility of hydrocarbon gases in crude oils

The gas solubility in crude oils depends on the pressure, temperature, and composition of gas and oil. The gas solubility in crude oil increases with increasing pressure and decreases with increasing temperature. The denser the crude oil, the lesser the gas solubility. Same effect is observed with increasing content of naphthene and aromatic hydrocarbons in crude oils.

The pressure at which the given oil is fully saturated with associated gas is called the saturation pressure. When the reservoir pressure drops below the saturation pressure, the dissolved gas is released from solution. If the reservoir pressure is higher than the saturation pressure, the oil is undersaturated. As temperature

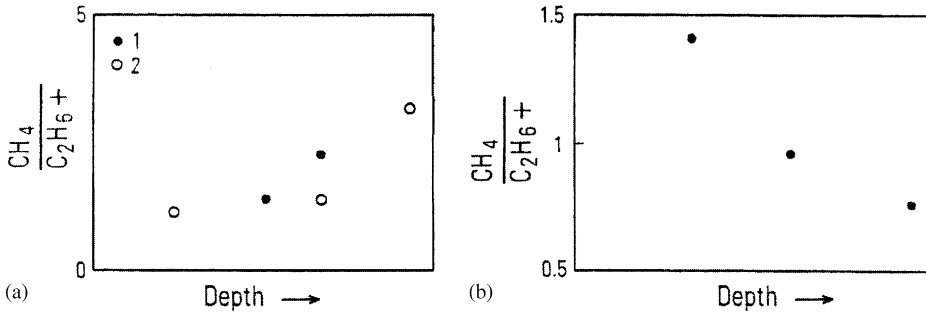

Fig. 6.4. Variation of $\text{CH}_4/\text{C}_2\text{H}_6+$ ratio with depth in (a) Palvantash and (b) Izbaskent fields. 1 — Gas in solution; 2 — free gas. (After T.A. Botnieva, in: Eremenko and Chilingar, 1996, p. 80.)

increases, the saturation pressure increases. The gas solubility in the crude oil increases with depth as the pressure increases. In as much as the heavier hydrocarbons dissolve first, the gas in gas caps becomes lighter. A totally different scenario occurs with gas compression and increase in temperature: liquid hydrocarbons in crude oil begin to dissolve in the natural gas.

The Palvantash and Izbaskent fields of the Fergana Basin (Uzbekistan), however, show the opposite trend in the natural gas enrichment in heavy components (see Fig. 6.4). The data from the Izbaskent field clearly indicate an inverse solution, which will be discussed in the next section.

6.4. PHASE TRANSFORMATION AND CONDENSATES¹¹

Changes in the reservoir pressure and temperature results in the redistribution of crude oil components between the liquid and gas phases. Gas–oil systems have a very complex composition. In order to simplify the discussion, the patterns in phase transformation for the simple binary systems (mixtures of methane and liquid hydrocarbon) are discussed.

Fig. 6.5 is a phase diagram of the methane–liquid hydrocarbon binary system of constant composition. The ACB curve enveloping the two-phase domain describes a constant composition system. Any change in the composition will affect its shape. The ACB curve consists of two branches: the bubble point curve AC and the dew point curve BC. When pressure is higher than the AC curve, the system is a single-phase liquid. Below the AC curve, vapor bubbles appear in the liquid and are maintained in a state of equilibrium with it. As the pressure in the system decreases, the amount of vapor increases. As the pressure rises above the dew point curve, liquid hydrocarbons drop out of the gas phase. The two-phase domain shows curves indicating iso-concentrations of the liquid phase in the system.

¹¹Modified after Zhuze and Sushilin (1984).

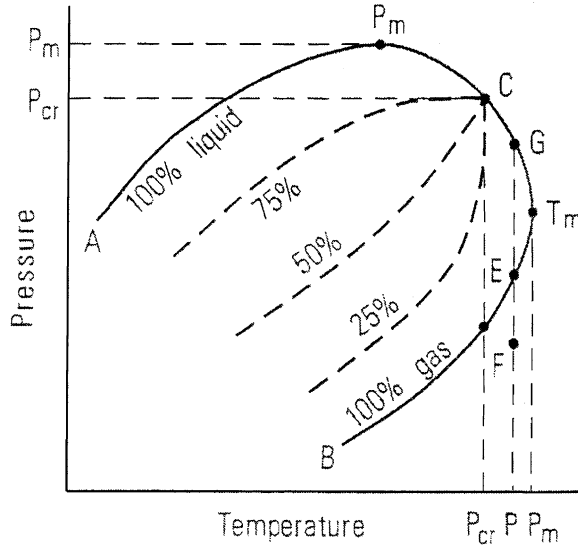

Fig. 6.5. Phase diagram of pressure versus temperature for a methane-liquid hydrocarbon binary system. (After Zhuze and Sushilin, 1984.)

As opposed to a single-component system, the critical temperature T_{cr} and critical pressure p_{cr} for a binary system are not maximal at the critical point C¹². At T_{cr} and p_{cr} , two phases may still coexist. Maximal points for a binary system are the cricodenbar p_m and cricodentherm T_m . When the temperature and pressure range between T_{cr} and T_m , and also when temperature changes within the pressure interval between p_{cr} and p_m (see Fig. 6.5), anomalous phenomena known as retrograde condensation occurs in the system. For instance, if the system at point F is isothermally compressed (at temperature T_E), then starting at point E, the liquid hydrocarbon will be released from the gas. The amount of the released liquid hydrocarbon increases, reaches a maximum and then declines to zero (at point G where the vertical line again intersects the vapor curve). This phenomenon is called isothermal retrograde evaporation. As the phase diagram shows, anomalous phenomena also occur within the p_{cr} to p_m pressure interval when temperature increases or decreases.

The critical temperature of the oil mixture may be approximately determined using the following equation:

$$T_{cr} = \sum T_{cr,i}m_i, \tag{6.22}$$

where $T_{cr,i}$ is the critical temperature of component i and m is its mass fraction in the system.

¹²Critical point: where material cannot be condensed regardless of the amount of pressure applied. The liquid and vapor phases merge at the critical point so that one phase cannot be distinguished from the other.

The additive rule is inapplicable for the calculations of p_{cr} for gas–oil systems: p_{cr} of the mixture is usually much higher than p_{cr} of any component. The greater the difference in molecular mass and nature of the mixture components, the greater the difference between the actual p_{cr} and the p_{cr} calculated using the additive rule.

All the above is true for a single equilibrium oil–gas system (in this case, methane–liquid hydrocarbon). The situation drastically changes if the system is not in equilibrium (for instance by increasing the molar fraction of methane). First of all, the shape of the ACB curve (see Fig. 6.5) changes. Besides, the excess of methane forms an independent gas phase (a gas cap at reservoir conditions). Thus, a transition may be observed in the reservoir between the equilibrium gas–oil system and the gas cap. This transition is gradual, with no distinct boundaries.

Numerous accumulations in West Siberia and North Caucasus, in terms of their phase state, are within the curve ACB (see Fig. 6.5). It means that they are in a transition vapor–liquid state, without a clear-cut gas–oil contact and gas cap (if it exists). Such “transition type” accumulations, depending on their position within the ACB curve, may be described differently on the basis of the well test results: (1) as gas–condensate accumulations with or without an oil leg or (2) as oil accumulations with a high gas/oil ratio (GOR) and a gas cap (with high condensate content), albeit the presence of a gas cap may not be confirmed later. The OWC (the interface) may be clearly definable at temperatures which are not high. At high temperatures (near the critical temperature), a distinct OWC is replaced by a transitional water–oil zone.

The phase diagram given in Fig. 6.5 clearly demonstrates mutual solubility of the liquid and gas phases, which was a subject of a number of in-depth studies (e.g., Zhuze, 1986). Fig. 6.6 shows the solubility isotherms of normal paraffin hydrocarbons C_3 – C_7 in methane. Left parts of the curves describe the normal condensation area of liquid hydrocarbons from the gas phase as the pressure in the system increases (e.g., Fig. 6.4 in the case of Palvantash Field). Right portions of the curves in Fig. 6.6 show the dissolution of liquid hydrocarbons in gas as the pressure in the system increases (e.g., Izbaskent Field; Fig. 6.4). With increasing molecular weight of liquid hydrocarbons, their solubility in compressed gases decreases (at the same temperature and pressure). The solubility of liquid hydrocarbons in gas increases with increasing branching arrangement. A significant increase in temperature and pressure also increases the solubility of liquid hydrocarbons in gas (with pressure having a more significant effect).

Liquid hydrocarbons dissolved in compressed gas are called the condensate. The gas and condensate in a gas–condensate accumulation exist in a single-phase state and obey the law of retrograde condensation. The condensate is composed of a mixture of gasoline and heavier oil fractions. The average boiling point temperature of condensate is below 200°C. Sometimes, however, it may reach 350–500°C (apparently when condensate is mixed with oil). Condensate differs from the gasoline fraction separated from the associated gases: gasoline has a boiling point temperature of 130–160°C, whereas condensate has a higher boiling point temperature. Condensate content in gas ranges widely from several cm^3/m^3 (Rudki Field) to 300–500 cm^3/m^3 (Vuktyl and Russkiy Khutor Fields) and even to 1,000 cm^3/m^3 (e.g., Talalayev Field). (The latter fields are in Russia.)

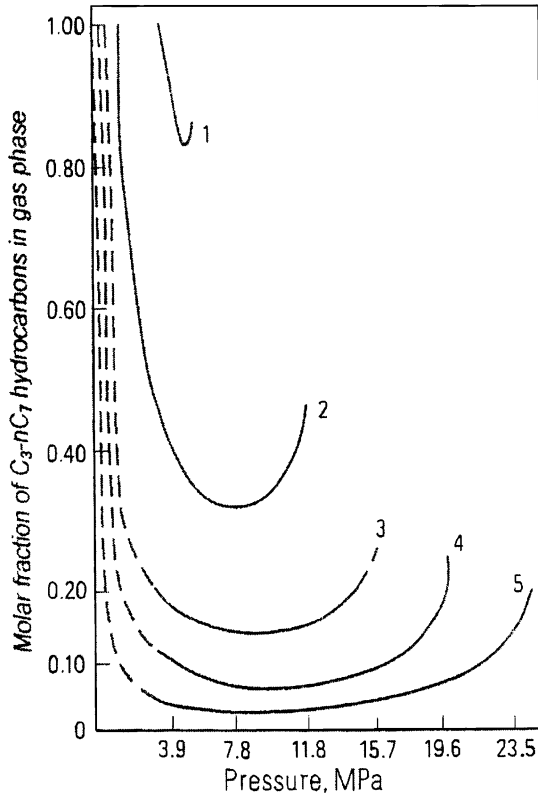

Fig. 6.6. Solubility isotherms of normal paraffin hydrocarbons in methane. 1 — C_3 (88); 2 — nC_4 (85); 3 — nC_5 (85); 4 — nC_6 (85); 5 — nC_7 (85). (Figures in parentheses represent temperature in °C.) (After Zhuze and Sushilin, A.V., 1984.)

Inasmuch as the gas-condensate accumulations follow retrograde behavior, a constant temperature and pressure must be maintained during their production. If pressure during the production declines, the condensate will drop-out of the gas phase as liquid, resulting in a loss of valuable product. The secondary recovery of the condensate from the reservoir is a technically involved and costly procedure. If the reservoir pressure declines, and the condensate partially drops-out of the gas phase, the condensate composition changes. In as much as the heavier fractions drop-out first, the remaining condensate becomes lighter.

Some geochemists (e.g., Starobinets et al., 1986) distinguish between the primary and secondary condensates. The primary condensate forms in a compressed gas due to dissolution of liquid hydrocarbons from bituminous rocks. The secondary condensate forms when liquid hydrocarbons from the oil accumulation underneath the gas cap dissolve in the gas. The meaning of this distinction is elusive. It may be that some petroleum geologists assign a genetic meaning to the term and, subsequently, try to prove the genesis through the assigned name. Naturally, the “primary” and “secondary” condensates in the same oil-gas basin and even in the same productive

formation may be somewhat different [because the sources (oils or bitumens) are different in composition]. The established distinctions may be utilized to reach certain geochemical conclusions within the oil- and gas-producing sequences in the same basin. Transposition of the established patterns outside of the oil and gas deposits (and even more so outside of the productive basin) is fraught with possible errors due to different compositions of compressed gases, oils, and bitumens.

It may be assumed that the "primary" gas-condensate mixtures are always undersaturated compared to the "secondary" ones. However, all "secondary" gas-condensates in the West Siberia were undersaturated regardless of their position above the oil accumulations (or oil rims). This phenomenon is still awaiting an explanation. The most likely reason is gravity separation. As mentioned earlier, gravity separation was observed in very thick gas accumulations. If the density range is wide, the gravity separation is likely. It may be expected that this situation will be maintained until the accumulation approaches its critical stage, when the role of gravity becomes insignificant. Until such time, samples obtained from different depths within the transition zone will show different saturation of oil in gas. Thus, the higher the sample location within the transition zone, the greater the difference.

*Chapter 7***DISPERSED ORGANIC MATTER**

7.1. ORGANIC MATTER INSOLUBLE IN ORGANIC SOLVENTS: KEROGEN

The content of kerogen in the rock–water–organic matter system is insignificant and varies between fractions of 1% and a few percentage points. However, its significance is greater than its content and may be compared to that of the accessory minerals in petrography: kerogen enables one, albeit not always, to solve various geochemical problems, including the oil and gas genesis.

The major part of the organic matter (OM) is represented by carbon, which is usually used as the basis for geochemical calculations. There is a correlation between the organic carbon content and lithology. The Clarke values of the total organic carbon (TOC) are: clays – 0.9%; siltstones – 0.45%; sandstones – 0.2%; and carbonates – 0.2% (Vassoyevich, 1984). This is a reflection of the depositional environments at the time of original organic matter accumulation in sediments.

Historically, the appearance of organic matter in sediments goes back to the origin of life on the Earth. Organic carbon is present in rocks as old as 4 to 4.5 billion years. Sidorenko (1978) suggested that the oldest accumulations of organic carbon-rich formations occurred 3.7 to 3.5 billion years ago. He identified the Priazov Series (Ukrainian Shield), Kola Series of the Kola Peninsula and the graphite gneiss of the Siberian Platform as such formations. Traces of organic matter are omnipresent in the Phanerozoic deposits. The dispersed organic matter can be divided into two categories: (1) soluble in organic solvents and (2) insoluble in organic solvents.

All living organisms comprise various combinations of the same carbon compounds: lipids, proteins, carbohydrates and lignin (for higher plants). In 1920, Potonie classified caustobioliths, according to their genesis, into humites and sapropelites. The humites are lignin-cellulose substances and liptobioliths, which form from tar, wax, spore shells, and cuticles. The sapropelites are transformation products of the simplest plant and animal remains, with or without preservation of original form. Same classification is applied to the dispersed organic matter. A weakly substantiated is the assignment of the humites to the continental genesis and the formation of various coals, and of the sapropelites to the major source matter for the oil and gas formation. Ammosov et al. (1987) proposed one more class: organofluidoliths, which are solid substances forming during migration of fluids (hydrocarbons or coaly fluids).

Dispersed organic matter of rocks may be classified into insoluble and soluble in organic solvents (chloroform, benzene, alcohol, methanol, acetone, ethanol, and their mixtures).

Insoluble Portion of Organic Matter

Some authors (Tissot and Welte, 1981) name the portion that is insoluble in either organic solvents or alkalis, the kerogen (the definition excludes bitumen). This insoluble portion is similar to coal. Chemically and petrologically, it includes the same components as coal. The microcomponents of coals are presented in Table 7.1.

Major components of insoluble portion of organic matter are carbon, hydrogen, and oxygen. Nitrogen and sulfur are present in a lesser amount. Tissot and Welte (1981), using Van Krevelen's (1961) graphs, identified three kerogen types on the basis of their elementary composition; they attribute a genetic meaning to their classification (Fig. 7.1).

Type I kerogen has a high initial H/C atomic ratio ≥ 1.5 ; the O/C ratio is < 1 . The kerogen is composed mostly of a lipid matter. Oxygen is present mostly in the ester bonds. When pyrolyzed, the volatile and extractable compounds including oil are produced. This kerogen type forms from the lipid-enriched organic matter.

Type II kerogen has a relatively high initial H/C atomic ratio (1–1.5) and a low O/C ratio. Polyaromatic molecule cores, heteroatomic groups of ketones, and carboxylic acids are of great importance. The bitumen associated with this kerogen includes many cyclic structures, and its sulfur content is higher than in the other component parts.

Type III kerogen has a relatively low H/C atomic ratio (< 1.0) and a high O/C ratio (0.2–0.3). It comprises a substantial extent of polyaromatic cores, heteroatomic and carboxylic groups, but does not contain ester groups. Apparently, the land plants constitute its main source.

All these kerogen types played different roles in the formation of oil, as discussed later.

As shown in Table 7.1, many microcomponents can be utilized to determine paleotemperatures. Main alteration in organic matter buried with the sediments is in the creation and, sometimes, preservation of substances that are stable during diagenesis and catagenesis. It is assumed that changes occur mostly due to the effect of heat. These processes are slow (millions of years), which is the case for most geologic processes (Amosov et al., 1987). Although the duration of natural processes is long, the speed of specific reactions may vary significantly. Role of the time factor in the natural processes needs to be understood better. For instance, as Lopatin (1971) pointed out, a temperature increase of 10°C causes the speed of kinetic reaction to double.

This simplified model has been utilized to reconstruct the geochemical evolution of many petroliferous basins. A number of writers, however, disagree with this concept. For example, Allen and Allen (1993, p. 284) believe that the above rule is applicable only in the temperature range of $50\text{--}60^{\circ}\text{C}$, above which the speed of kinetic reaction substantially changes (for instance, it is just 1.4 at 200°C). Tissot et al. (1987) have limited the applicability of the Lopatin's technique by the activation energy of no higher than $10\text{--}20\text{ kcal/mol}$. Price (1985, pp. 233–240), on the other hand, believes that alterations of heterogeneous compounds in nature follow more complex laws.

TABLE 7.1

Microcomponents of coals (after Ammosov et al., 1987)

Brown coals			Hard coals		
Group	Microcomponents	Paleotemperature determination technique	Group	Microcomponents	Paleotemperature determination technique
Alginite	Teloalginite	F ¹	Alginite	Teloalginite	F ¹
	Colloalginite	?		Colloalginite	?
Algo-humite	Saprohumite	N/a ²	Algovitritine	Saprovitritine	n/a ²
	Helinite, textinite, caprohuminite, ulminite	R ³		Collinite	R ³
Huminite	Textinite, ulminite	R ³	Vitritine	Tellinite	R ³
	Attrinite, densinite	?		Vitrodetrinite	R ³
Interohuminite	Oxyhuminite	n/a ⁴	Interovitritine	Semivitritine	n/a ⁴
	Macrinite, micrinite	n/a ⁵		Macrinite, micrinite	n/a ⁵
Intertinite	Semifusinite, fusinite, sclerotinite, interdetrinite	n/a ⁵	Fusinite (intertinite)	Semifusinite, fusinite, sclerotinite, inertodetrinite	n/a ⁵
Liptinite	Spirinite, kuptinite, resinite	F ¹	Liptinite	Sporinite, cutinite	F ¹
	Liptodetrinite, subdetrinite, chlorfullinite	?		Retinite, liptodetrinite	?

Note: 1 – stages of thermal transformation are determined from fluorescence (F) or from color and optical density in transmitted light; 2 – not suitable for paleotemperature determination; 3 – stages of thermal transformation are determined from vitritine reflectance (R); 4 – reflectance is too high; not suitable for paleotemperature determination; 5 – react weakly to changes in temperature and pressure; not suitable for paleotemperature determination.

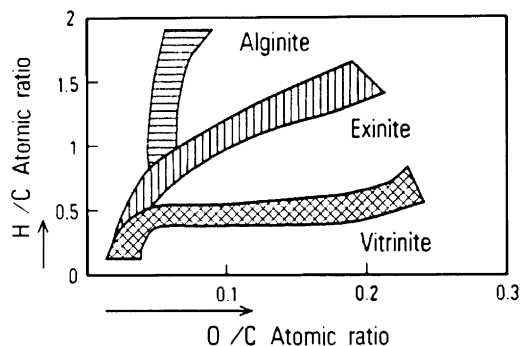

Fig. 7.1. Coal maceral evolution curves (modified after van Krevelen, 1961; also see Larsen and Chilingar, 1967).

Generally speaking, it would be unrealistic to expect a single energy threshold for complex natural compounds and numerous chemical reactions they undergo. It is obvious that both initial and final values of energy threshold (and speed of processes and composition of end products) will change depending on the type of mixture.

According to Glesston et al. (1948), the energy threshold (activation energy) is a natural boundary at which the reactions begin. Until that boundary is exceeded, the system may be considered as practically stable under the existing energy environment.

As far as the field observations are concerned, Price (1983) noted that the effect of time factor was overestimated, because the difference in geothermal gradients in different regions was not taken into account. Koshman (1985), however, disagrees with this view. Also, very intriguing results were obtained in the laboratory studies by Rohrback et al. (1984). They studied the effect of temperature on various sediments and found that vitrinite reflectance changes from 0.2 to 3.0% on heating from 35 to 550 °C during the time interval of 1 to 15,000 h (which is just a drumbeat, geologically speaking).

Thus, one may suggest that the alterations in the coaly matter occur rapidly at first, after which the matter may preserve its acquired properties for a long time. An inference from the latter might be that the alterations of coaly matter occur not as much from the amount of heat received but from reaching the necessary temperatures. Andreyev et al. (1958) indicated that the duration of achieving the stable state for organic matter is always much lower than the residence of the system in stable state. Moskvina (1981) reached a similar conclusion: time does not affect the degree of alteration of organic matter. Allen and Allen (1993, p. 284), on the other hand, do not exclude the effect of time on the organic matter alteration. Lopatin (1983), summarizing ideas of the time and temperature effects on the organic matter transformations, prepared a graph (Fig. 7.2). As shown later, heat flow is not the only energy source in the subsurface (Shvetsov, 1974; Trofimuk et al., 1981).

Out of all the components of coals presented in Table 7.1, vitrinite is considered to be the most suitable for determination of paleotemperatures. Paleotemperatures are

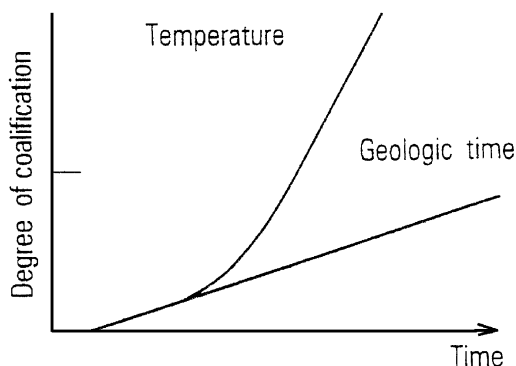

Fig. 7.2. Conceptual curve showing temperature and geologic age as coalification factors (modified after Lopatin, 1983).

determined based on vitrinite reflectance as measured in oil (R_o) or in air (R_a). This, however, poses some problems. One such problem is the selection of a reliable sample and a suitable area of that sample for the determination of maximum reflectance. A number of R_o or R_a values can be determined for the same sample and a maximum value must be selected. But there is no guarantee that the selected value is indeed maximal: there may be some areas in the samples where these values are greater. According to Ammosov et al. (1987, p. 23), the reason for that is the non-uniformity and incompleteness of alterations of the solid substance and the preservation of such a state indefinitely under given thermobaric conditions. Non-uniformity of organic matter accumulation and distribution in any sample cannot be argued. At the same time, studies by Yu. V. Stepanov (in: Ammosov et al., 1987, p. 82) of alterations in a series coal-sandstone-siltstone-argillite indicate a certain direction for increasing R_o . Price (1982), Price and Barker (1985), and Price et al. (1986) recorded changes in the hydrogen content of kerogen. Hydrogen enters the vitrinite and alters its reflectance. The coal samples from the same coal bed, containing more hydrogen, display lower R_o .

Ammosov et al. (1987, p. 26) believe that some errors may have been caused in the determination of vitrinite reflectance not in the true vitrinite but in the vitrinite homologs, such as saprovitrinite, semivitrinite and, sometimes, pseudovitrinite, which have been confused with true vitrinite. True vitrinite reflectance is lower than that of semivitrinite and pseudovitrinite and higher than that of saprovitrinite. According to Ammosov, this might have caused erroneous conclusions by Price and others.

Despite some disagreements, most authors are of the opinion that vitrinite may be used as a maximum paleothermometer and for determining the degree of catagenesis in the surrounding rocks. Table 7.2 is a comparison chart for regional temperatures, stages of catagenesis, and vitrinite reflectance.

Lithogenesis includes diagenesis, epigenesis, and metamorphism. Vassoyevich (1975) changed the term epigenesis to catagenesis and subdivided it into different stages.

TABLE 7.2

Comparison of regional temperatures with vitrinite reflectance (after Ammosov et al., 1987)

Paleotemperature forecast (°C)	Vitrinite reflectance R_o (%)	Paleotemperature forecast (°C)	Vitrinite reflectance R_o (%)
75	0.45	185	1.12
90	0.5	190	1.22
110	0.55	195	1.27
115	0.59	200	1.37
125	0.63	205	1.42
135	0.70	210	1.56
145	0.76	215	1.66
155	0.83	220	1.76
165	0.90	225	1.92
175	0.97	230	2.10
180	1.09	235	2.45

Inasmuch as vitrinite alterations are irreversible and its reflectance is preserved after a subsequent temperature drop, reflectance can be used for the determination of paleotemperatures. Table 7.2 assumes a direct correlation between temperature and R_o values. This correlation, however, is not always straightforward. For example, Ammosov et al. (1987) presented graphs of vitrinite reflectance vs. depth for the Jurassic deposits of the Pre-Caucasus region (Fig. 7.3) and of the present-day temperature vs. depth for the same formations (Fig. 7.4). As shown by the graphs, there is no correlation between R_a and either depth or temperature. The writers believe that an attempt to explain this by the subsequent tectonic inversion with the preservation of R_a with the declining temperature is not convincing. One of the authors of quoted publication, V.I. Gorshkov, is convinced that there is no correlation between temperature and vitrinite reflectance. High reflectance gradients do not necessarily correspond to the high paleotemperature gradients. Thus, one should be cautious in using vitrinite reflectance for determining paleodepths of prospective petroliferous rocks.

It is important to stress again that it is possible to obtain different R_a and R_o values for the same rock sample. This is due not only on the spatial difference (inclination angle) between the studied maceral elements, but also the degree of catagenetic maturity of different organic matter components, which may differ in their (1) initial composition, (2) current chemical composition, (3) syngenetic or secondary origin, and (4) size. Ammosov et al. (1987) recognized that various components react differently to thermobaric conditions in the subsurface and have different ranges for the diagenesis, epigenesis, catagenesis, metagenesis, and metamorphism. Thus, boundaries of lithogenetic stages as determined from organic matter or from sedimentary rocks in general are not precise (Ammosov et al., 1987, p. 310). Saxby (1982) also suggested that some corrections must be made to the kerogen transformation scale using R_o . According to him, the lower boundary for the oil window should be moved up to $R_o = 1-2\%$, and for the gas window, to 5%.

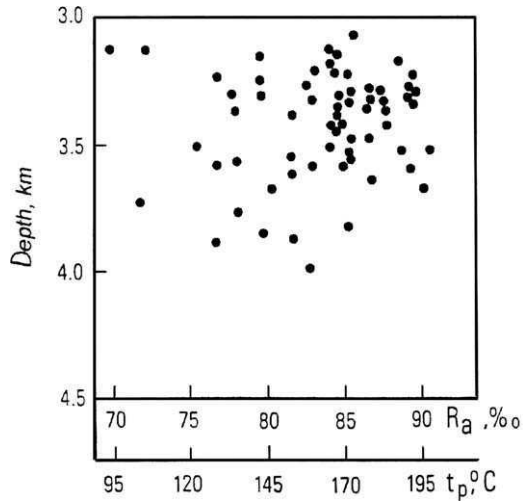

Fig. 7.3. Vitrinite reflectance R_a of the Jurassic sediments vs. depth (modified after Ammosov et al., 1987).

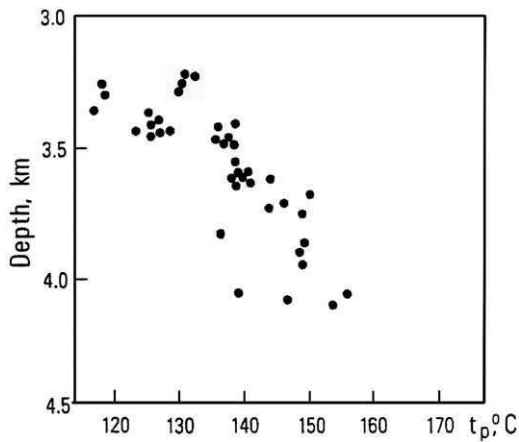

Fig. 7.4. Present-day temperature of the Jurassic sediments vs. depth (modified after Ammosov et al., 1987).

Despite all the above, so far the vitrinite thermometry is the major technique for the determination of paleotemperatures and lithogenetic stages of sedimentary rocks.

Some scientists studied the possibility of oil generation from coal and its components. Saxby and Shibaoka (1986) studied extracts from volatile components of coals and concluded that there is a possibility, in certain geochemical environment, of the oil generation from coal. Its preservation, however, is possible only if oil is expelled prior to the beginning of gas generation. These authors stated that exinite is the maceral most prone to the oil generation. It can generate oil 10 times greater than vitrinite and 100 times greater than inertinite (fusinite). They also believed that all

known oil reserves in the Gippsland and Cooper basins of Australia may have been generated as a result of the thermal maturation of coals, even if just 1% of the generated hydrocarbons was captured in the traps.

Baird (1986) suggested that liptinite was the main source maceral for oil, whereas vitrinite was for gas. Inertinite was inert. Tissot and Welte (1981) believe that most hydrocarbons of natural gases were generated as a result of thermal transformation of kerogen during catagenesis. They also believe that the insoluble portion of the organic matter (i.e., kerogen) has properties of a molecular sieve. This conclusion was based on the following experiments: upon extraction, some samples were treated with acid, and then extracted again. After second extraction with organic solvents, bitumens with some hydrocarbons were released from the kerogen samples. Similar studies with repeated extraction after treatment with the hydrofluoric acid have been conducted by Akramkhodzhayev (1973), Akramkhodzhayev and Amirkhanov (1977), and Akramkhodzhayev et al. (1978). They discovered not only saturated but also unsaturated hydrocarbons in the second extracts. In the discussion that followed these studies (Eremenko and Tverdov, 1980; Karimov and Kalapov, 1983) it was found that unsaturated hydrocarbons may be retained by kerogen in sorbed state, which is important for the problem of oil generation.

Ammosov et al. (1987), in discussing organic matter in the sedimentary rocks as a whole, indicated that both humic and sapropelic organic matter is converted into solid, liquid, and gaseous phases in the subsurface. Migrating liquid and gaseous phases interact with the mineral and organic components of the surrounding rocks and produce new compounds, called organofluidoliths. The genetic associations (with either humic or sapropelic matter) are erased in an organofluidolith. Ammosov et al. believe that the liquid and gaseous organofluidoliths participate significantly in the oil generation.

It is interesting to review the distribution of oil reserves in the sedimentary rocks as a function of R_o , R_a , and temperature. According to Ammosov et al. (1987), major oil reserves are found with $R_a = 62-93$, $R_o = 0.33-1.29$, and temperature of 100 to 150 °C. As the temperature increases the process slows down. Above the temperature of 200 °C, oil generation cannot occur ("dead zone"). Saxby (1982) believed that the oil generation can proceed until $R_o = 2$, the condensate generation until $R_o = 3$, and the gas generation until $R_o = 5$. Price and Barker (1985) stated that a limitation of the oil generation interval to the R_o range of 0.6-1.35 (which is broader than the Ammosov's) is wrong. The R_o value of vitrinite, which is usually enriched in the invaded hydrogen, is suppressed. The correct value is about 3-5 notches higher, i.e., the $R_o = 6-8$.

All aforementioned alterations in the composition of coals and coaly matter in the sedimentary rocks are attributed by many authors to the thermal effects. All attempts to find a correlation with the dynamic stress were either unsuccessful (Ammosov et al., 1987) or not clear (Ignatchenko, 1968; Stefanova and Shimorina, 1981). It is important to mention here Strakhov's (1960) opinion that not all natural processes are a result of changes in the thermodynamic conditions. Some are due to internal energy of the system, which is released as a result of equilibration of the system.

7.2. ORGANIC MATTER SOLUBLE IN ORGANIC SOLVENTS

Organic matter (OM) in a deposit includes a substantial amount of organic compounds, which are easily dissolved in the organic solvents and are easily hydrolyzed. Tissot and Welte (1981, p. 84) showed that some free and hydrolyzed organic compounds contain fatty acids, hydrocarbons, sugars, and amino acids. Their total content is low and amounts to 15–40% of the organic matter even in the near-surface layer of sediments. At a depth of 0–15 m, they constitute 6% in the Saanich Bay, British Columbia, 25% in the Bering Sea, and 40% in the central part of the Black Sea. In all cases, their content rapidly decreases with depth due to the bacterial activity and becomes less than 1% at a depth of 35 m. Microbially processed organic matter is transformed to an insoluble state through the condensation and polymerization during diagenesis to a depth of a few tens or a few hundreds of meters. Lipid compounds (including hydrocarbons) are quite stable. They transfer from the living matter into the sediments and, subsequently (after diagenesis), into rocks without or with only slight changes. These compounds have a relatively high molecular weight. Tissot and Welte (1981, p. 124) proposed to call “chemofossils” the molecules that have been synthesized by the living plants or animals and enter into the sediments with only slight changes and with the preserved molecular structure of hydrocarbons or other lipids. Most important chemofossils are alkanes, fatty acids, terpenes, steroids, and porphyrins. Quantitative hydrocarbon determinations in the present-day sediments have been performed by Gorskaya (1950) (Black Sea) and Hunt (1981).

It was established in the laboratory that if subjected to the effects of temperature or physicochemical reactions, kerogen is capable of releasing hydrocarbons. Usually, these hydrocarbons have lower molecular weight and a simpler structure than chemofossils. Thus, compounds extracted from rocks by organic solvents may have a double origin: inherited from the original organic matter (chemofossils) and newly formed compounds.

The soluble part of the dispersed organic matter is called bitumen. Petroleum geochemists studied the bitumen in detail because of the established similarity of its light portion with oil. The kerogen was studied in detail by the coal geochemists.

The kerogen-sorbed saturated and unsaturated hydrocarbons have been discovered by Akramkhodzhayev (1973) while studying bitumens. They are of special interest. The unsaturated hydrocarbon release-curve from a heated and solvent-treated kerogen is bimodal. The first maximum is observed at 100 °C, whereas the second one at 300 °C or above. The first maximum cannot be explained by the thermal disintegration of complex hydrocarbon, ester, and other side chains of kerogen (Nametkin, 1955). It contradicts a physicochemical law of an increase in the intensity and speed of chemical reactions with increasing temperature. Of interest is the total decrease in the released hydrocarbons in the temperature range of 100–150 °C. This also cannot be explained by the hydrocarbon formation as a result of the organic matter decomposition. The most plausible interpretation is desorption of hydrocarbons from organic matter.

Thus, it may be suggested that the unsaturated hydrocarbons released from kerogen at ≈ 100 °C (and even 300 °C) are products of biosynthesis and are inherited,

together with other hydrocarbons, from the original organic matter. Some geochemists cast doubt on such a hypothesis over a high reactivity and instability of unsaturated hydrocarbons. The high reactivity and instability of unsaturated hydrocarbons in natural environments are relative, however. There are published data on the presence of unsaturated hydrocarbons in crude oils of different geologic age and at different depths. For instance, small amounts of hexylenes, octylenes, and nonylenes have been identified in a Canadian crude oil. Unsaturated hydrocarbons are present in the crude oils from the North Caucasus, Emba Area (Russia), and Sakhalin Island (Nametkin, 1955). It may be further suggested that the preservation conditions for the rock-sorbed unsaturated hydrocarbons may be even better than those in the accumulations. This agrees with the idea of Burst (1969) that bonded water has the preservation effect on hydrocarbons. This is supported by the presence of unsaturated hydrocarbons in gases released during a vacuum degassing of rocks not only in shallow but also in deep wells.

Various organic solvents are used to extract the bitumen. They include chloroform, benzene, acetone, and mixtures thereof. The most commonly used solvent is chloroform. It usually extracts the maximum amount of bitumen from the ground rocks. These bitumens are usually more reduced as compared with the bitumens extracted with the other solvents.

Elementary (C, H, S, N, O) and group (lubricants, resins, asphaltenes) composition is studied in the extracted bitumens. All available techniques are applied for their studies such as liquid and gas chromatography, mass spectrometry, X-ray, UV and IR microscopy, and electromagnetic resonance. Bitumens have been studied to the same depths as those for the crude oils.

With all the other conditions being same, the content of bitumens in the rocks increases with increasing organic matter content. Simultaneously, their relative content in the organic matter of rocks declines. This is especially apparent when the organic matter content in rocks is low. Also, there is an increase in the reduced bitumens.

There is a correlation between the bitumen content and the lithology (Table 7.3, based on calculations by Vassoyevich (1984) conducted in 1973). Since then, despite a tremendous increase in the accumulated data, no appreciable changes in principle have occurred.

As mentioned before, the bitumens are composed of oils, resins, and asphaltenes. Most oils contain all compounds found in crude oils, the first being hydrocarbons. The elementary composition of bitumens is also close to that of crude oils, except for a higher content of heteroelements (O, N, S) in bitumens.

Table 7.3 also contains data for rocks with the concentrated forms of organic matter. The content of both bitumens and hydrocarbons is rather high there. This is just another indication that such rocks may have contributed to the oil generation and, even more so, to gas generation. The absence of large commercial oil and gas reserves in such rocks is explained in the subsequent sections.

Organic matter in the carbonates is more bituminous, and the degree of their reduction increases with the increasing carbonate content (Vassoyevich, 1971).

Some geoscientists recorded the oxidation of bitumens in argillaceous deposits in the proximity of reservoir rocks (whether up or down the section). Neruchev and

TABLE 7.3

Approximate subclarke values of organic matter (OM) components in various sedimentary rocks at catagenetic stages MC₄ and lower (after Vassoyevich, 1973)

Rock	TOC (%)	Bitumen (chloroform-extractable bitumen)			Hydrocarbon content (%)		
		Content (%)		Total mass in continental deposits (10 ¹³ t)	In rock	In OM	In bitumen
		In rock	In OM				
Clays	0.9	0.06	5	36	0.02	1.7	30
Silts	0.45	0.03	5	5.7	0.01	1.7	30
Sands	0.2	0.016	6	2.6	0.005	1.9–1.95	40
Carbonates	0.2	0.03	11–12	6.3	0.012	1.9–1.95	32
Salts, sulfates	0.1	0.01	7.5–8	0.04	0.003	2.3	30
Coals	67	0.8	0.9–0.95	0.025	0.15	0.2–0.25	18–20
Oil shales	16.5	1	4.5–5	0.06	0.2	0.5–0.1	20
Dominikites, Bazhenovites	6	0.6	7.5–8	1.8	0.25	4–4.2	40–45
All continental rocks (excluding lavas)	0.62	0.045	5.4–5.8	52.5	0.0115	1.8–2	34–35

Rogozing (1992), Kartsev (1984), Kontorovich (1991), and others explained this by the migration of more reduced portion of bitumens into the reservoir rocks. Laboratory modeling based on chromatographic studies (e.g., Yermakova et al., 1988) showed that, after a slight thermal treatment (under 300 °C), the tar generates hydrocarbons, such as *n*-alkanes and isoprenoids. Reactions of hydrolysis of esters, decarboxylation of acids, and dehydration of alcohol have also been established.

It was found that the composition and content of bitumen change in the section. This was linked to the zonation of oil and gas generation in sedimentary section and resulted in the development of concept of the “main phase of oil and gas generation” (oil and gas window).

Figure 7.5 shows conceptual diagrams of zonation of oil and gas generation. Most stratigraphic sections exhibit a maximum in the bitumen content at a depth of 2–6 km. Also shown are maxima for the gas content and associated condensate content. This depth interval corresponds to the mesocatagenetic stage. Almost all schemes show a clear bitumen maxima at the mesocatagenetic stage, but the maximum’s boundary shifts somewhat from one scheme to the next, and not all of the schemes include the upper gas peak. The evolution of the “main phase” concept moved the studies of oil and gas source rocks forward. Their geochemical parameters, depositional environments, and temperature intervals (60–130 °C) have been established in many parts of the world. Yet, some unanswered questions still remain.

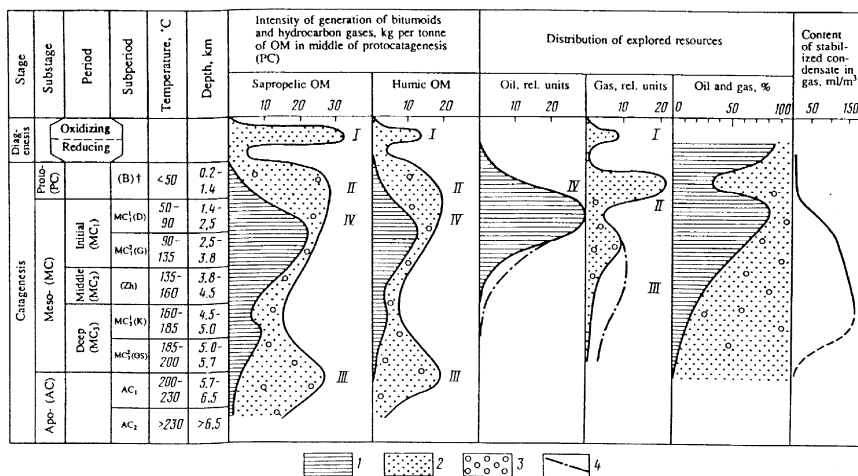

Fig. 7.5. Conceptual diagrams of zonation of oil/gas generation in stratigraphic section (by Eremenko and Tverdova, 1980, modified after Sokolov, 1965; Tissot, 1971; Kulbitskiy, 1973; Alekseyev, 1973; Vassoyevich, 1975; Kontrovich and Trofimuk, 1976; Weber, 1978). Intensity of oil and gas generation: 1 – oil and bitumoids; 2, 3 – hydrocarbon gases; 2 – CH₄ 3 – C₂H₆-C₅H₁₂; 4 – hypothetical distribution of resources when exploration has reached a depth of 1–3 km. I – Diagenetic zone of intense gas generation and gas-hydrates accumulation; II – upper zone of intense gas generation and accumulation; III – deep zone of intense gas generation and accumulation; IV – main zone of oil generation. † Letters in parentheses in this column denote the corresponding rank of coal. (In: Eremenko and Chilingarian, 1991, p. 536.)

Regardless of the age of rocks (therefore, the duration of geochemical processes), all sedimentary basins of the world exhibit the bituminosity peak, which determines the "main phase" of oil and gas generation (i.e., oil and gas windows), at about the same depth. Why is that? It was found that the depth may change depending on the heat flow. Some regions display a compressed, and some others, stretched geothermal zonation (changes in the geothermal gradient). This clarification, however, does not answer the question.

Why is it that in different regions, regardless of the age of rocks, there is only one "main phase" of oil generation, occurring at present time (present-day sample collection and analyses)?

Based on the restoration of depositional and geochemical processes, there must have been several such phases in various basins. The present-day geochemical and thermodynamic status of sedimentary basins is usually not unique and does not contradict the appearance in the times past of similar geochemical and thermodynamic environments. Lastly, why is it that the theory of the "main phase" considers the heat flow as the only energy source? Are not there other energy sources in the Earth crust?

In an attempt to evade all these questions, alternative concepts have been developed. One example is a concept of the oil and gas generation cycles. The entire process of generation, existence of oil, and destruction of these accumulations was called an oil- and gas-generation cycle (Maksimov et al., 1972). This concept is discussed in the chapter devoted to the hydrocarbon generation.

The bitumen extracted from the samples of different ages reflects the depositional environment of organic matter, diagenetic and catagenetic alterations, and the expulsion of most volatile-substances from it. The theory of the "main phase" stresses the transformations during diagenesis and catagenesis. At the same time, the initial conditions (the depositional environment) and the final conditions (the expulsion of volatile substances) remain in the background.

If one accepts the alternative view of oil- and gas-generation cycles and its treatment of the process as continuous, but varying in intensity, most of the above questions can be answered. Currently observed bitumen maxima may not reflect the "main phase" but may reflect any other phase, and the main phase must be established for each particular area. As stated before, temperatures in excess of 100°C are most favorable for the hydrocarbon desorption. Therefore, the hydrocarbons generated within the corresponding rock intervals are easily removed. This is supported by the coinciding minimum on Akramkhodzhayev's (1973) curves reflecting the recovery of additional hydrocarbons from the previously extracted rock samples. Neruchev and Eremenko (1968) suggested a great role of the expulsion processes in such a situation.

7.3. COMBINED STUDIES OF SOLUBLE AND INSOLUBLE PORTIONS OF ORGANIC MATTER

Determination of soluble (bitumen) and insoluble (kerogen) portions of the dispersed organic matter is necessary for its complete characterization. Chemical and

physical techniques for studying the dispersed organic matter are complex or require expensive, sophisticated equipment.

A technique that became very common over the last 10 to 15 years is a pyrolysis technique introduced by Espitalie and others in 1971, which is called RockEval. It is based on heating the kerogen sample to 550 °C, following a predetermined heating program. The first peak (S_1) of the curve corresponds to the free and adsorbed hydrocarbons evaporated at a moderate heating to 200 °C–250 °C. The second peak (S_2) reflects hydrocarbons and other similar components generated at a higher temperature due to pyrolysis of the insoluble portion of kerogen. Finally, the third peak (S_3) reflects CO_2 and water.

Tissot and Welte (1981, p. 413) suggested that the value of S_1 represents the fraction of initial genetic potential that has been transformed into hydrocarbons. The S_2 value is the residual potential. The total $S_1 + S_2$ (usually expressed in kg/ton) indicates the total genetic potential. When $S_1 + S_2$ is less than 2 kg/t, the rock is not considered to be a source rock, whereas when $S_1 + S_2$ is equal to 2 to 6 kg/t, the rock is considered to be a source rock with a moderate hydrocarbon generating potential. If $S_1 + S_2$ is greater than 6 kg/t, the rock has a high hydrocarbon generating potential.

A kerogen type is determined by two characteristic parameters: (a) the hydrogen index (S_2/C_{org}) and (b) the oxygen index (S_3/C_{org}). There is a good correlation between the hydrogen index and the H/C_{org} atomic ratio, as well as between the oxygen index and the O/C_{org} atomic ratio.

It is recommended to use the ratio [$S_1/(S_1 + S_2)$] (transformation index) and the temperature for determination of the organic matter maturity. It was found that the transformation index does not depend on the type of organic matter. On the other hand, the type of kerogen depends on the temperature, especially during diagenesis and early catagenesis. Tissot and Welte (1981) stated that the temperature is lower for the continental kerogen (type III) and higher for the marine or lacustrine kerogen (type I and type II). Yet, the temperature is almost the same for different kerogen types in the maximum oil generation zone and later in the gas generation zone.

To characterize the components of S_2 peak, gas-chromatography is utilized. It was found that the source of chemofossils (long-chained normal alkanes) in the kerogen of modern deposits is higher plants. Modern deposits are dominated by the molecules with odd numbers of carbon atoms. With depth, new alkanes with shorter carbon chains are generated, and the odd/even ratio inequality levels off.

It was proposed to use the ratio [odd n -alkanes/even n -alkanes] or [odd n -alkanes/(even n -alkanes + odd n -alkanes)] to characterize the degree of kerogen transformation or its maturity. The limitation here is the dependence of these parameters on the kerogen type and the transformation conditions.

Another frequently used parameter is the isoprenoid distribution. It was shown that the pristane/phytane ratio changes in the process of the thermal evolution of coals. This ratio, therefore, can be used to characterize the Type III kerogen. This has not been proved, however, for the kerogen of Types I and II.

Trofimuk et al. (1982) opposed the use of the above-mentioned parameters for the identification of source rocks and determination of their potential. Trofimuk et al.

stated that S_1 and, hence, the bitumen represent just a remnant preserved in rocks after the hydrocarbon expulsion. This remnant may be continuously replenished to a certain extent due to the continuity of processes. The degree of replenishment depends on many factors including the composition of the original organic matter. The type and the speed of reactions depend on the extent of coalification of the original organic matter. As Neruchev et al. (1986) indicated, most stable components must gradually accumulate in the organic matter.

Thus, the genetic potential ($S_1 + S_2$) and the transformation coefficient are also in doubt. Taking into account what was mentioned about the S_1 , the genetic potential is incomplete, because a substantial (maybe even major) fraction of the chemically active organic matter is not considered.

At the same time, S_2 includes some components that cannot be converted into hydrocarbons in the natural environments (and, probably to a large extent, in the laboratory) and, therefore, cannot affect the hydrocarbon reserves. Hence it is quite risky to associate this "potential" with actual hydrocarbon resource potential. The same applies to the transformation index [$S_1/(S_1 + S_2)$], which probably cannot indicate the degree of transformation of organic matter. Rather, it is just an indication on the incompleteness of the processes of organic matter transformation.

It is important to determine whether the particular bitumen is autochthonous or allochthonous. Comparisons have been made of the hydrocarbons in the crude oils (in the reservoirs) and in the rocks. The former are enriched in the saturated hydrocarbons, moderately enriched in aromatics, and strongly impoverished in polar (N, S, O) components.

Using thin sections, Larskaya (1983, p. 200) made an attempt to combine petrographic and chemical parameters for a more reliable identification and description of source rocks. Carbon isotopes were also used in studying bitumens and kerogen. The bitumens are enriched in $\delta^{13}\text{C}$ by 2–3‰ compared with the kerogen. The crude oil has the same carbon isotope composition or is slightly lighter (by 1–2‰) than the genetically associated bitumen.

Akramkhodzhayev et al. (1978) introduced a technique for determining whether bitumen is autochthonous by comparing its carbon composition with that of the bitumen extracted by heating kerogen.

Attempts have been made to evaluate the amount of hydrocarbon generation from the changes in [$S_1/(S_1 + S_2)$] ratio with depth. The formation of accumulations must correspond to the abnormally high values of this ratio against the background of an average curve. Such evaluations, however, did not gain any substantial recognition due to their inaccuracy.

Uspenskiy (1970) proposed to determine the amount of generated hydrocarbons (oil source potential) from the elementary composition of kerogen. It is possible to determine the composition of the initial and final kerogen using the kerogen from the same formation obtained from different depths (corresponding to various catagenetic stages). It is also possible to determine the losses of elements during the formation of hydrocarbons and their removal due to heating (in the form of compounds such as CO , CO_2 , H_2O , CH_4 , and H_2S). Thus, according to Uspenskiy, one can calculate the amount of released hydrocarbons.

The concept proposed by Uspenskiy, however, is questionable. He equated the amount of volatile coalification products (that form when the dispersed organic matter matures from one catagenetic stage to the next) with the difference in the amount of volatiles per combustible mass in the technical analysis of coal. It was found, however, that the adjacent points in the same rock sample may have a substantially different elemental composition. Consequently, the elemental analysis results for two samples collected at different depths within the same formation may lead to totally different conclusions. This is due to non-uniform composition of the accumulated organic matter (in terms of the number, composition and even the size of particles) and the non-uniformity of the effect of geochemical factors that result in different degrees of transformation of organic matter at different locations within the rock. The organic matter itself also affects the geochemical environment. Thus, determination of the true degree of transformation and the amount of released hydrocarbons is a complicated problem. This pertains to all types of point (local) determinations in rocks.

The above-presented concepts and parameters are commonly used for the identification of source rocks, determination of the degree of their maturity, and estimating the amount of hydrocarbons formed during lithification. The ideas of Potonie (1920) and Uspenskiy (1970) are still commonly accepted, and the sapropelic organic matter is a preferred source for oil generation.

In their experiments, Rohrback et al. (1984) used deltaic (humic) and algal-lagoonal (sapropelic) oozes and heated samples from 35 °C to 550 °C for 1 h to 625 days. The time and the composition of the input material affected the products. Three stages have been identified:

1. *Immature*: C_1 through C_{5+} hydrocarbons are released; C_{15+} hydrocarbons are absent.
2. *Mature*: The bulk of the C_{15+} is released. The released CH_4 is isotopically lighter than in the input material.
3. *Overmature*: The amount of released C_2 – C_5 hydrocarbons increases again. The CH_4 formed is isotopically heavier than in the input material.

Simultaneously, the R_o changed from 0.2 to 3%. Liquid hydrocarbons begin to form at $R_o = 0.25\%$, maximum is reached at $R_o = 0.5\%$ in the humic organic matter and at 0.7%, in the sapropelic organic matter. Liquid hydrocarbons are formed faster in the humic ooze. Tissot and Welte (1981, p. 421) also recorded a faster and more complete formation of liquid hydrocarbons from the humic matter.

It is important to note sudden change in the carbon isotopic composition of methane at Stage 2. A similarity may be observed here with the bacterial sulfate reduction experiments by V. Mekhtiyeva (personal communication, 1994). In these experiments, first the isotopically heavy H_2S was formed, which became heavier upon further experimentation. This phenomenon, however, was only observed in a closed environment. When the new batches of the input material were supplied, the increase in isotope composition of sulfur in H_2S stopped.

Of course this comparison is tentative, because in one case the reactions were chemical, whereas in the other, they were biochemical. Still, the concept arises that the carbon in methane in natural environments does not have to become isotopically

heavier: the amount of initial matter in the experiments by Rohrback et al. (1984) was limited by the size of the sample, whereas it does not have to be limited in nature. In other words, when the amount of initial matter is sufficient, during the formation of products (CH_4 and H_2S in these cases), the bonds with the matter are severed first for the light isotopes, and only then for the heavier ones.

In the initial rock–water–organic matter system, the last link (OM) is highly sensitive to the changes during diagenesis and subsequent catagenesis (epigenesis). The direction of processes transforming the organic matter during diagenesis and catagenesis and the resulting products are clear. Obviously, the most stable components accumulate. It may be suggested that this link (OM) loses energy (increase in entropy) during diagenesis and catagenesis. However, the organic matter transformation processes and their effect on the energy status of the entire system is not clear. The potential role of the spontaneous reactions upon overcoming the energy threshold is also not clear. The studies that have been initiated in the effects of sources other than heat energy on the organic matter transformation are discussed later in this book.

This page intentionally left blank

*Chapter 8***ORIGIN OF OIL AND NATURAL GAS**

8.1. INITIAL ORGANIC MATTER AND ITS TRANSFORMATION

The studies of origin of oil always concentrated on the determination of organic matter and establishing processes of its transformation. Discussions in the preceding chapters clearly point to the organic origin of all discovered oil and gas accumulations. Especially significant is Chapter 5 on the oil composition. Chemofossils are present not only in oil but also in coal, oil shale, and bitumen, i.e., biomarkers of organic compounds that preserve the structure of transitional bioorganic molecules. More than 300 such hydrocarbons are described in crude oils. About the same number of biomarkers were discovered in the sulfur- and oxygen-containing compounds. Quite often, more than half of the crude oil is represented by biomarkers that are, therefore, not an admixture but an integral constituent of oils.

The main concepts of the organic theory of oil generation [e.g., Mikhailovskiy, 1906; (in: Eremenko and Chilingar, 1996); Arkhangelskiy, 1954; Gubkin, 1915, 1932] are simple. Organic matter is accumulated (mostly in a dispersed state) in predominantly clayey marine deposits. There are two major types of organic matter: humic and sapropelic. It was believed that the latter played a major role in oil generation, whereas the decomposition of humic organic matter resulted in the formation of coal and water-soluble (hence, easily dispersible) substances and gas.

The decomposition of sapropelic matter gives rise to the liquid and gaseous compounds including hydrocarbons. The decomposition occurs as a result of heat flow and the energy of the sun accumulated by the organic matter. The hydrocarbons and some other substances formed from the decomposed organic matter are squeezed together with water out of the shales into the reservoir rocks. The hydrocarbons derived from the organic matter float in the water medium (gravitational theory) and move until trapped in the reservoir.

Marine origin of oil source rocks appeared to be obvious, although it is unclear why the first oil-bearing sequences developed in different countries were continental or near-shore marine Paleogene and Neogene rocks. The studies of the present-day sedimentation indicated that all marine and almost all continental deposits contain organic matter. It was eventually recognized that only the presence of subaquatic sediments, either of marine or continental origin, was required.

Potonie (1920) indicated that there were three ways for organic matter to “burn” in nature: combustion, smoldering, and rotting. The latter process was believed (Mikhailovskiy, 1906; Potonie, 1920; Gubkin, 1932; Strakhov, 1960) to be responsible for the organic matter formation in nature. This is an important issue for at least two reasons: rotting occurs without the supply of oxygen; from the outset, the process is believed to be isothermal.

Strakhov (1960) stressed the need for strongly reducing hydrogen sulfide geochemical facies. As a result of his idea, pyritized sequences have been included among the source rocks. Later, Strakhov changed his mind.

The quantitative presence of organic matter in rocks was reviewed first by Trask and White (1915, in: Eremenko and Chilingar, 1996, p. 153). According to Arkhangel'skiy (1954), sediments may be classified as source rocks if they contain organic matter at least 2% or 43 kg/m^3 . The absolute amount of organic matter buried in various genetic types of sediments depends on many factors, but mainly on the biological productivity of source organisms and by the facies environment during burial. Relative organic matter concentration also depends on the depositional speed. For example, due to a very slow rate of deposition, organic matter content in the Central Polar Basin reaches 1%. Generally, organic matter concentration in sediments widely ranges between trace amounts and 100% (in peat).

Trofimuk et al. (1980, 1982) believed that the content of a dispersed organic matter in source rocks may be even lower, because part of it had been spent to generate oil and gas that have been expelled. Some other investigators believe that less than 1% of organic matter is converted into oil; thus, the expulsion loss could not significantly affect the residual carbon distribution in sediments.

Many scientists (e.g., Kontorovich et al., 1975; Nazarkin, 1994; Bordovskiy, 1974) recognize the effect of depositional rate on the qualitative and quantitative outcome of the organic matter transformation. First, the relative increase in the organic matter concentration is observed. Then, the rate reaches $50\text{--}200 \text{ tons/km}^2/\text{year}$ and the depositional rate decreases due to the organic matter dilution by minerals (Nazarkin, 1994). Rieke and Chilingarian (1974) found that, with other conditions being equal, the value and duration of AHFP also directly correlates with the depositional rate. The depositional rate in most known oil and gas basins is between 150 and $1000 \text{ tons/km}^2/\text{year}$.

The major geologic factor in transforming organic matter into bitumen is the compaction of rocks under the overburden pressure. Brod and Eremenko (1950) stated that the oil and gas generation process is lengthy and continuous: "... Hydrocarbon compounds arise as a result of competition between two opposite trends: when subsidence prevails over uplift, during small as well as large oscillations of a given Earth's crust area."

Oscillations of the Earth's crust are the cause of relationships among the depositional processes, rock formation, and structural development. Sedimentation is responsible for the accumulation of organic matter in deposits. Lithification is responsible for the organic matter transformation, whereas the structural development (tectonic activity) is responsible for the formation of combustible fossil fuel accumulations, their metamorphism, and destruction.

"Oil and gas generation is, therefore, an unalienable part of the Earth's crust evolution and involves dynamic processes. It is not just a simple mechanical displacement but consists mainly of complex transformations. These transformations consist of biologic, geochemical, physicochemical, and other changes. They manifest themselves jointly, but play different roles at different stages of oil and gas generation".

On the basis of laboratory studies, Zhuze (1957, in: Eremenko and Chilingar, 1996, p. 154) developed a concept of clay-mineral transformation from montmorillonite to kaolinite during rock compaction. He questioned the limitations imposed on the role of clay minerals, as just catalysts in the transformations of organic matter. This concept, in turn, has been questioned by Klubova (1973), who believed that such a process could not proceed in nature due to insufficient supply of potassium in rocks.

A number of authors recorded the clay-mineral alterations during catagenesis. As an example, Nazarevich et al. (1985) described montmorillonite alterations during meso-catagenetic (MC) stage and cessation of this process upon reaching the MC₄ substage. Brillling (1984, in Eremenko and Chilingar, 1996, p. 154) noticed that in the process of alterations, the particles (sheets) change their orientation, which results in locking-up or opening of pores; hence, the filtration in clays acquires a random, unstable nature.

The following questions arise in studying the oil generation in source rocks (mostly shales):

1. What is the nature of source rocks and where and how are they distributed in sedimentary basins?
2. What is the physical state of hydrocarbons in source rocks?
3. What forces (and at what stage) cause them to move to the reservoir rocks (primary migration/expulsion)?
4. When and how do hydrocarbons move within the reservoir rocks to form oil and gas accumulations?
5. What is the relation between (a) the oil and gas composition in the accumulations and (b) the environment of hydrocarbon generation and of formation of accumulations?

Vassoyevich (1976) introduced the term "microoil": The origin of oil begins with the living matter where the biochemical compounds are born that initiate formation of petroleum hydrocarbons or, to a smaller extent, where these hydrocarbons are born. Upon deposition at the bottom of a basin, and partially forming in the sediments due to the activity of organisms, these hydrocarbons and prehydrocarbons form a young microoil.

Although Brod (1957) did not accept the term microoil, his views were similar to those of Vassoyevich. According to Brod, while building their bodies, cellular membranes and other cellular structural elements, plant and animal cells and, especially, some bacteria synthesize hydrocarbons. After death of the organisms and inclusion of their remains in the depositional cycle, the hydrocarbons contained in them may be decomposed by the microbial activity. The relative rate of hydrocarbon decomposition is lower than that of the other organic compounds. Thus, under favorable conditions some hydrocarbons may accumulate.

Quoting Uspenskiy (1970), Vassoyevich stated that the components of oil were not born all at once. In his view, it would be better to discuss not the source but the hydrocarbon generation stages that would correspond to the stages of lithogenesis. Brod (1957) also mentioned that hydrocarbon compounds dispersed in rocks do not constitute crude oil. Various organic compounds formed from the moment of initial deposition, whereas mixtures of liquid hydrocarbons (i.e., crude oils) apparently formed during the formation of accumulations in reservoirs.

According to Brod, various components of oil could have formed at different stages of organic matter transformation and at different lithogenetic stages. Thus, a complex chemical system called crude oil formed within reservoirs in the process of the formation of accumulation. That is why Brod could not accept the term microoil: in his view, hydrocarbons and non-hydrocarbon organic compounds dispersed in rocks are not macro- or microoil.

It appears that Vassoyevich (1976) was correct in concluding that integrated geological and geochemical studies of the modern and ancient sediments provide evergrowing body of data, which indicates that each stage of lithogenesis is accompanied by its own characteristic hydrocarbon generation. It should also be remembered that the parent organic matter is also changing simultaneously (Maksimov et al., 1977).

The Vassoyevich's concept of a relation between the hydrocarbon generation and catagenetic stages was broadened into the doctrine of oil and gas generation cycles (Eremenko et al., 1949, 1978; Maksimov et al., 1972, 1976). As discussed later, the "stagewise" and "cyclic" nature do not have the same meaning. In discussing the organic matter transformation into crude oil, it is necessary to consider the transformation factors.

The major error implicit in most hydrocarbons-to-crude oil transformation concepts is the attribution of an exclusive role to a single factor. This will result in the detachment from the natural environment where all these factors are operative and intertwined. The transposition of laboratory experiments onto the natural environment, without a full account for its multifaceted character, always results in errors. Besides, an active energy influence on the source organic matter is attributed to each factor. At the same time, no serious consideration was given until recently to the energy facet of the issue, although it is only natural that organic matter in itself has the sufficiently high reserves of energy for the subsequent transformations.

It was suggested that the living matter accumulate the sun energy, which is subsequently transferred to the organic matter. It appears that this is not accurate. The heat of the Earth itself should not be forgotten. All geologically "live" planets, including the Earth, release much more heat than they receive from the Sun. The processes of life cannot ignore that energy source. One confirmation of the above is the presence of life at great depth in the oceans, where the sunlight does not reach. No doubt, the energy stored in the living organisms or in organic matter is much greater than that in the oil or coal. The processes of transformation of matter with loss of energy are very common in the Earth's crust.

8.2. STAGewise NATURE AND CYCLIC TRANSFORMATION OF ORGANIC MATTER

The issue of stagewise transformation of organic matter was analyzed by many. As the energy is concerned, there is no significant disagreement in the identification of the organic matter transformation stages. There is some disagreement regarding the stage boundaries (especially in the case of temperature), but this, in our opinion, is of minor importance.

The processes of oil and gas generation can be subdivided into four stages. During the first two stages, the organic matter exhibited energy change from the higher forms (biological and chemical energy) to the lower forms (heat and mechanical energy). The initial organic matter for the oil generation was in a dispersed state. Its further migration and the formation of accumulations represent the energy concentration from the dispersed organic matter, which cannot occur due to its own internal energy.

If the first two stages of oil and gas generation may have occurred as a result of mobilization of the internal energy, then the third stage required an external energy. The source of this energy lies in geological processes (tectonic movements). Thus, the third stage must be associated with (1) significant restructuring of the oil and gas basins, (2) disruption of equilibrium in these basins, and (3) emergence of forces causing changes in the potential energy of fluids that appeared within reservoirs by that time. In such a case, the process of formation of accumulations may be taken as a process accompanying the energy equalization in beds, in a general direction of the process toward attainment of the surface of World Ocean (assumed zero level of the potential energy of fluids).

The stagewise nature of the organic matter transformation cannot be compared with the cyclicity of the oil and gas generation process any more than a "part" that can be compared to the "whole": one is part of the other. The stages of the organic matter transformation can be compared with the catagenetic cycles identified by Vassoyevich (1975).

Vassoyevich used the coal "metamorphism" in Donyets Basin of Ukraine for his classification of the oil-generating processes. Initially, the main generation phase was placed between 80°C and 150°C. Later, the temperature ranges have been modified. Vassoyevich stated that the main stage (main phase) of the oil and gas generation occurs as the source rocks reach the mesocatagenesis zone (minimum temperature of 60°C). Generation of new hydrocarbons is significantly increased (including, for the first time, low-molecular-weight hydrocarbons). The mesocatagenesis usually occurs at a depth between 2.7 and 8 km and at a temperature between 210°C and 280°C (Vassoyevich, 1975).

It is interesting to note that the depth/temperature of the mesocatagenetic zone corresponding to the hydrocarbon window (main phase) does not coincide with the zone of oil reserves encountered at a depth of 1–2 km. The gap is between 0.7 and 7 km. The thickness of some oil- and gas-producing formations does not exceed 300 m. Thus, the proponents of the main phase would have to take position of the mandatory vertical migration for the formation of hydrocarbon accumulations. The writers do not rule out the possibility of formation of oil accumulations due to a distant vertical migration, but believe, however, that the vertical migration usually is limited to the oil- and gas-producing formation.

The writers agree with Vassoyevich (1975) that of primary interest to the petroleum geologists are depositional cycles, because the sedimentogenesis, i.e., birth (genesis) of the sediment, is a crucial stage of lithogenesis. During sedimentogenesis, sediment may become a source rock, good or poor reservoir, or a seal. Changes during the diagenesis, catagenesis, methagenesis, and hypergenesis greatly depend on the initial type of the deposit.

If the organic matter transformation stages are associated with, or may be related to, the lithogenetic stages, then the oil and gas accumulation must be associated with the geotectonic evolution of large regions of the Earth with sedimentary cycles.

The transformation process of a given organic matter within a given lithological sequence is irreversible. The cyclic nature of the oil and gas generation process implies the repetitiveness, or its possibility, of the oil and gas generation for a given region of the Earth's crust, but for different lithological (sedimentary) sequences.

The concept of the main phase (oil window) is widely accepted. Evaluation of the hydrocarbon potential of a basin, and the timing of hydrocarbon generation and formation of accumulations were determined based on this concept. Lopatin (1971) proposed to use a simplified form of the Arrhenius law,¹³ according to which the rate of chemical reactions doubles when temperature increases by 10°C.

The oil window concept is continuously evolving and improving, especially with regard to the calculations of oil and gas source potential based on the elemental composition. The main task is to develop a model of the dispersed organic matter transformation that would realistically reflect the natural processes and balance the mass of the original dispersed organic matter with the residual dispersed organic matter and all gas, liquid, and solid generation products. In 1982, Neruchev and Rogozina stated that such a model does not exist. Later, however, it was stated (Neruchev and Rogozina, 1992) that such a model has been developed. In such a model, however, one should consider the scatter of the elemental composition data, even within a single sample. Thus, it would be easy to stack the analyses and show a negative course for the catagenesis.

As Kontorovich (1991) indicated, the depositional rate and the heat flow change in time depending on the processes occurring at depth. As a result, the rate of hydrocarbon generation in oil and gas basins and the total mass of hydrocarbons generated per unit of time sporadically change with time. Due to this, even within the twin basins one may find somewhat different oil and gas areas and non-identical sets of largest hydrocarbon accumulations. Besides, the transposition of coal thermolysis laboratory experiments onto the dispersed organic matter in the natural environment is quite tentative (Uspenskiy, 1970).

The above-presented ideas are similar to those mentioned before on the stress-energy state of the sediment cover (and of the source rocks in particular). Such a system tends to reach an equilibrium. Leveling of the energy non-uniformity occurs by way of the energy redistribution within the system (source rocks) and its transfer (together with fluids) into the adjacent beds with a lower potential energy. This process is unavoidably accompanied by other plastic and fracture (hydrofracturing) deformations.

In the case of a natural hydraulic fracture, the pressures are applied within the bed; with all other conditions being equal, only the bed resistance to extension must be overcome. Zhel'tov and Christianovich (1956, in: Eremenko and Chilingar, 1996, p. 159)

¹³Arrhenius's rate equation provides the rate R of a thermally activated process: $R = R_0 \exp(E_a/k_sT)$, where R_0 = a constant, E_a = the activation energy, k = the Boltzmann constant, and T = the absolute temperature.

found such stress to be between 0.5 and 1.5 MPa. At the same time, only because of organic matter transformation in the adjacent zones, pressure gradient of several to several tens of MPa may form in the source rocks. Thus, migration paths form non-uniformly within the formation. Energy redistribution in the rock-water-organic matter system occurs as a result of internal and external energy sources, within each limited bed volume containing organic matter. High-energy saturated compounds, which formed within the system, will most likely move, according to the laws of film migration, toward the areas with a lower energy or into the adjacent reservoirs.

8.3. ROLE OF ENERGY IN THE OIL GENERATION PROCESS

The major stimulus for the evolution of process of oil generation is the internal energy of the organic matter. The other factors serve as peculiar catalysts that initiate the process, affect its speed, or influence the nature of the final products. There is a major disagreement among petroleum geologists regarding the role of internal energy in the course of organic matter-to-oil transformation processes.

Nesterov et al. (1992) studied the thermodynamic aspects of organic matter transformation. Some petroleum geologists believe that a vertical or lateral movement of the heated fluids (heat-mass transfer) may explain the appearance of heat anomalies. They do not rule out the possibility of heating some sequences (or zones) due to exothermal effect resulting from: (1) gas generation within the high-temperature thermal-catalytic zone; (2) exothermal reaction of hydrocarbon generation from the dispersed organic matter; and (3) specific hydration conditions by the donor hydrogen in the course of radical thermal decomposition reactions. A problem arises of how to determine the level of heat effect of oil generation and the role of catagenetic transformation of organic matter in the presence of heat anomalies.

A thermodynamic solution of individual equations is insufficient due to the complexity of geological system. Studies of the thermal dissociation of organic matter showed that the endothermal reactions are usually dominant. Various factors determine the expenditure of heat energy needed for kerogen decomposition. They include the (1) number and type of broken chemical bonds, (2) formation of different (based on mass) stable paramagnetic centers (PMC) and free radicals (FR), and (3) desorption of volatile reaction products.

With increasing temperature, the weakest bridge bonds in kerogen are broken. This results in loosening of the fragmental structure, redistribution of the electron density, and an increase in the PMC concentration. The energy necessary for breaking the bonds ranges from 20–40 kcal/mol. As the temperature increases above 350°C, the number of stronger bonds broken (C–C, C–H and C–OH bonds) increases. A breaking thermal dissociation above 450 to 550°C (at $E_a = 60\text{--}80$ kcal/mol) results in breaking of most alkide bonds (C–H, H–H). When the expended energy is above 150 kcal/mol, the structure of the source organic matter is totally destroyed. Heat release (exothermal reactions) occurs only on the condition of hydration by hydrogen, formation of molecules through the recombination of FR, polycondensation of unsaturated bonds, etc.

Two options have been discussed by Nesterov et al. (1992). The first option involved a continuous removal of reaction products from the reaction zone. This enabled to model the generation and simultaneous expulsion of the volatile products of decomposition. This thermal destruction model was referred to as a "tentatively open" system. The second option involved heating the kerogen at the same rate of temperature increase, but within vacuumed and then sealed quartz tubes. This option ("closed system") involved the thermal destruction at a constant volume, without the release of reaction products and with an increasing pressure, analogous to the conditions of sealed pores or accumulations.

The study indicated that the thermal destruction of the kerogen and coaly inclusions with increasing temperature within a "tentatively open" system, regardless of the type of the source organic matter, requires an input of thermal energy.

Continuous thermal alteration of kerogen under the "tentatively open" model, with the continuous removal of reaction products, requires an input of thermal energy. Thermal energy input for the decomposition of organic matter and for the formation of products of the process occurs in the form of individual impulses (endo-effects) associated with certain temperature intervals. Energy release due to secondary recombination and molecule neoformation reactions (at the expense of redistribution of hydrogen) is insignificant and does not compensate for the overwhelming energy intake during the kerogen decomposition.

The thermal transformation of the organic matter and the catagenetic boundaries of heat parameters coincide with the hydrocarbon generation phases. Thus, it is likely that the hydrocarbon generation process in the source rocks increases to a certain thermal boundary (to MC₄-MC₅ stages), above which the thermodynamic kerogen decomposition occurs at a lower level of heat expenditures.

The writers suggests the following conclusion about the speed of thermal effect on the source rocks. If the oil generating sequence subsides into the heating zone slowly enough, then the thermal decomposition process required to reach the oil window will occur at a lower level of activation energy (up to 40 kcal/mol), and at a heat expenditure of 120 kcal/kg of kerogen.

Neruchev et al. (1992) also observed thermodynamic alterations in the process of organic matter transformation. According to their experiments, as the depth and temperature increase in the catagenetic zone, the complex structural transformation of organic matter is accompanied by several alternating maxima and minima of heat release that causes this transformation. The maxima are mostly associated with the stages of intense transformation of organic matter molecules and the generation of substantial volumes of volatile products. The minima (endothermic zones) mainly correlate with the reshaping and stabilization of the structure of organic matter with a small amount of generated volatile substances. As the depth and temperature increases, the scale of heat released from the organic matter transformation decreases. The process progresses toward endothermic reactions, which is in compliance with general principles of thermodynamics. Usually, exothermal reactions occur at relatively low temperatures. As the temperature increases, the process shifts toward endothermic reactions.

As mentioned before, the rate of heating of organic matter must affect substantially the yield and composition of the generated product. According to Urov (1992, p. 126), at a low rate of heating the mobile hydrogen atoms from the cyclic areas of kerogen have enough time to migrate to the periphery of micromolecules. The separation and transfer of hydrogen occurs; aliphatic side chains detach mostly as saturated compounds, and the solid residue gradually loses hydrogen and is carbonized. Price et al. (1986) also mentioned that a hydrogen-rich organic matter (sapropelic) requires higher temperatures for transformation.

The potential energy of oil and gas is the transformed solar energy buried with organic matter. The accumulation and sometimes the release of potential energy is a thermodynamically viable process for the entire Earth's crust and, in particular, for the sedimentary rocks. An example is the formation of argillaceous sequences (accumulation of the surface potential energy) and their subsequent transformation with a loss of energy.

The energy of organic matter (buried solar energy) is insufficient for its transformation into oil and gas. Thus, an input of additional energy is required to initiate (and accelerate) chemical reactions. The input of additional energy could be the heat of the Earth.

If the internal energy of organic matter is insufficient for the generation of oil and gas, and the additional energy is required, then the 100-year-old controversy of the organic vs. inorganic origins of petroleum becomes meaningless. The discussions on this subject are fruitless (Zhabrev, 1993). Even the most common orthodox version of the organic hypothesis by Vassoyevich (1975, 1976, 1979) with the "main phase" (heat of the Earth) appears to be dualistic. The fraction of inorganic hydrocarbons in the Earth's crust at this time, optimistically, is no more than a few percent, and most likely just a few tens of 1% (Zhabrev, 1993, p. 12). Thus, the following two questions arise:

1. What processes provide for the accumulation of potential chemical energy and what traces of these processes can be identified in the oil?
2. What energy sources may have been utilized, and which ones are most likely?

Undoubtedly, the endogenic heat has been among the major energy sources. However, many exothermal processes occur in the lithosphere, and their energy may have been utilized to transform (and to move) organic matter and its derivatives.

Mostly, the heat field, which is one of many energy fields of the Earth, has been studied with respect to its association with the oil and gas generation cycles. The electromagnetic field is poorly studied in this respect. There are reasons to believe that the electromagnetic forces directly affect chemical reactions and lower the activation thresholds. They certainly affect the migration of petroleum. These forces should be additionally studied based on the concepts of (1) the Earth as a capacitor with the minus in the crust and the plus in the ionosphere; (2) the Earth as an electric power generator (rotation of a conductor in the magnetic field).

Here, the writers would like to mention the term "electrodiagenesis" introduced by Serruya et al. (1967). Movement of fluid (due to compaction of sediments, for example) generates potential gradients, which in turn may affect the diagenetic

processes. Electrical currents cause interstitial solutions to flow through practically impervious muds (from positive to negative “electrode”).

What are the possible effects of electric currents on the oil generation from organic matter? This question should be answered first by the experimental work in the laboratory.

The Earth’s radioactive field is being carefully studied, especially during the recent decades. The formation of hydrocarbons and other compounds from organic matter as a result of radioactivity is established. A connection between radioactivity and oil fields (and bituminous sequences, e.g., the Bazhenov Formation, Russia) has been established. Additional work, however, is needed in this field.

There is a possibility of the low potential energy directly transforming into the chemical high potential energy. During the recent years, the effect of mechanical fields attracts evergrowing attention. Some authors attempted to apply it to the problem of organic matter transformation in the Earth’s crust. Thus, the geodynamic compaction and seismic activity may be considered as energy sources during the oil-generation cycle.

It should be mentioned that Ignatchenko (1968) discussed the possible effect of seismicity on the coals, quoting A. A. Gapeev’s experiments on the effect of impacts. Ignatchenko stated that although there is no convincing evidence of the metamorphic effect of the elastic waves on organic matter, there is a need for further studies.

The energy, which causes elastic and plastic deformations of rocks, also significantly affects the entire complex of physicochemical processes of the organic matter generation and accumulation. A field survey and a laboratory modeling (by Yu. A. Pitsukha) indicate that during the tectonically caused plastic deformations of sedimentary rocks, these rocks are mechanically activated. As a result, various physicochemical processes occur. In the process, the tectonomechanical energy is converted within the rock matrix into electric, heat and chemical forms of energy. The released energy, with active participation of the chemically and physically adsorbed water molecules, causes spontaneous processes, which result in the generation of hydrocarbons and various organic-mineral compounds.

A laboratory study of seismic action on rocks (conducted by Siberian scientists: N. V. Cherskiy, V. P. Tsarev, and T. I. Soroka) showed that certain changes occur in response to weak elastic deformations at 30–40 Hz frequency and temperature between 20°C and 70°C. They include an increase in carbon content and decrease in hydrogen content within the insoluble portion of organic matter, and increase in the role of aromatic structures. At the same time, hydrocarbon content significantly increases in the soluble portion of organic matter (in: Eremenko and Chilingar, 1996, p. 163).

Thus, mechanochemical reactions may help transform the source organic matter and generate hydrocarbons in a low-temperature environment as a result of elastic and plastic deformations.

One must be very careful when transferring laboratory results to the natural environments. The Earth does not have thermodynamically isolated coats (covers). The energy transfer occurs as conduction (heat) and convection (mass). Classical hypotheses of organic origin of oil accept only the convection energy transfer into

the sedimentary cover. Sh. F. Mekhtiyev, B. A. Sokolov, etc. (in: Eremenko and Chilingar, 1996) allow some participation of the convection energy in the oil generation. This is quite plausible based on what we know about the Earth's coats/covers. The proponents of inorganic origin insist that the petroleum accumulations form by convection only. This statement is ruled out by the majority of scientists although neither side has a convincing proof.

It will be very hard to prove that the (gas, liquid?) flows that exist can form hydrocarbon accumulations with a pressure of 50 MPa or greater. At least, there are no known gas deposits associated with subcrustal sources and containing enough hydrocarbons at a sufficient pressure. A concept developed long ago by Stadnikov (1931, 1937) suffered from the fact that there is insufficient amount of hydrogen in the Earth's crust. Crude oil differs from the living matter in its absence of oxygen and over-abundance of hydrogen. Thus, Stadnikov (1937) had to introduce the concept of hydrogenation by the hydrogen migrating from great depth.

Molchanov and Gontsov (1992) suggested that hydrocarbons can be synthesized at room temperature and normal pressure in a medium capable of generating hydrogen. Hydrogen forms from the interaction between water and oxidizing minerals that contain the sulfide of sulfur and protoxide of iron. Atomic hydrogen reacts with the carbon (i.e., prior to the formation of H₂ molecules). The energy source is the dispersed mineral mass.

Molchanov and Gontsov (1992) consider the oil generation as a chain conjugate-radical reaction initiated by the hydrogen at the moment of its "release". The mechanism of radical reactions was first suggested by Maksimov et al. in 1959. This proposal was later supported by the discovery of free radicals in crude oils (this was not known in 1959). This concept was developed further by Galimov (1973). He concluded that the reactions, which are thermodynamically impossible at given temperatures, may actually take place. Thus, heat is not necessary and is not a required precondition for the oil and gas generation (Galimov, 1973, p. 223). Price et al. (1985), Rohrback et al. (1984), and Nesterov and Shpilman (1987) also stressed the importance of radical reactions in the formation of hydrocarbons.

This page intentionally left blank

Chapter 9

FORMATION OF HYDROCARBON ACCUMULATIONS

9.1. SEDIMENTARY BASINS

Oil and gas fields in any sedimentary basin are not distributed uniformly. They form non-uniform assemblages, and each one of these assemblages usually has stratigraphically similar oil- and gas-bearing deposits with similar regional geology (exceptions to this rule, however, are known). Such assemblages can be called “oil and gas accumulation zones”. They may form (1) around a large field, (2) over a large arch, (3) satellite fields, and (4) without a large field, thus composing an “association”. Such assemblages may include a number of fields more or less of equal size (depending on the size of traps) along (a) the structural swells, (b) some pinch-out zones, or (c) stratigraphic unconformities on monoclines. Sometimes, in the center of a massive plate, it may be quite difficult to identify a structural unit, which controls association of several fields. It is not necessary for every hydrocarbon field to be a member of an oil and gas accumulation zone. There could be an independent “zone” with a single field.

Grouping of hydrocarbon fields associated with large structural unit determines some common features of the environment of formation of accumulations and fields within an oil and gas accumulation zone. This is predicated on the similarity of the formation of sediment sequences, which, in turn, is based on the common tectonic evolution of the region and on similar conditions of formation of traps of various types. The identification of oil and gas accumulation zones at different exploration stages ensures the success of exploration operations and enables one to forecast the subsurface temperature, pressure, and phase composition of hydrocarbons.

The oil and gas accumulation zone is sometimes called a “trend”. The latter, however, is most commonly used to describe a linear distribution of fields with the productive deposits of about the same age. It should not be confused with the term “play” that presupposes not so much the structural commonality as the commonality of oil and gas sequence. Thus, two or more “plays” may be included in a single oil and gas accumulation zone. As an example, in the northeastern Caucasus, with its frontal ranges, there are two oil and gas accumulation zones, which include four plays of Tertiary and Cretaceous age in each zone. On the other hand, a single play may include the oil and gas deposits associated with different oil and gas accumulation zones. In the above example, there are two plays (Tertiary and Cretaceous) for the two oil and gas accumulation zones but each play involves both zones.

Otis and Schneidermann (1997) evaluated four different concepts of exploration based on the degree of knowledge about the specific geologic feature:

1. *Basin concept*. Basin concept involves an assessment of (1) the potential of source rocks, (2) capacity of reservoirs, (3) capacity of traps, (4) sealing properties, (5)

proper timing of trap formation, and (6) proper timing of migration. This assessment is a screening device only, and does not include commercial considerations.

2. *Petroleum system concept.* Petroleum system concept involves a volume of sedimentary rocks containing hydrocarbons, charged by a single source rock. Application of this concept requires the presence of the manifestations of hydrocarbons (seeps, shows, or a producing well); it is applicable in many frontier basins only by analogy. Recognition of an active petroleum system also serves as a screening device because it carries no volumetric and, therefore, cannot estimate a commercial value of HC resources.
3. *Play concept.* The play is an elemental part of a petroleum system, and is recognized as having one or more hydrocarbon accumulations identified by a common (1) geological character of the reservoir, trap, and seal, (2) timing of migration, (3) preservation, (4) location and environment, (5) fluids, and (6) flow properties. Individual plays have unique geological and engineering features, which can be used as a basis for commercial assessment.
4. *Prospect concept.* The prospect is an individual, potential accumulation. Each prospect is perceived as belonging to an individual play, characterized by risk components and a probabilistic range distribution of potential hydrocarbon volumes within its trap confines.

Based on the position of an oil and gas accumulation zone, play, or prospect within a larger structure (oil-gas basin) may help forecast some parameters of hydrocarbon accumulations.

Many publications are devoted to the classification of sedimentary petroliferous basins (see e.g., Eremenko and Chilingarian, 1991). Common features of all definitions and classifications are (a) stressing the processes of oil and gas generation, and (b) more rarely, the processes causing the formation and destruction of hydrocarbon accumulations.

The formation and destruction of accumulation is affected not only by broad events in the basin or its major portions (e.g., folding), but also by the local events within the adjacent areas, such as the erosion of the crest of anticline or appearance of a conducting fault. The authors do not believe that the "oil and gas basin" should be identified as a distinct category. The identification of sedimentary basin would be quite sufficient (Vassoyevich, 1975). A sedimentary basin may be petroliferous if it contains commercial oil and gas accumulations. If the presence of commercial oil and gas accumulations is only assumed, such basin is called the prospective basin. At the same time, this basin may be coal-, gold-, uranium-bearing, etc.

Numerous attempts have been undertaken to find the pattern in the distribution of accumulations in relation to the plate tectonics concept. The oil and gas accumulations are discovered in the central and marginal parts of the tectonic plates, with the greatest number of accumulations present at the margins.

No qualitative or quantitative patterns in the distribution of accumulation have been discerned in the passive versus active margins. The passive margins appear to have somewhat more reserves. The hypothesis of the hydrocarbon involvement in the subduction zones with the subsequent transportation along the fault zones to the

sedimentary basins, where they form oil and gas accumulations, is not supported by field data. Many oil and gas basins do not have even a hypothetical connection with the subduction zones (e.g., West Siberian, Michigan, and Paris basins).

Based on many oil and gas origin hypotheses, it may appear that the active margins should have an advantage in terms of the amounts of hydrocarbons generated (and their lighter, more alkane composition) because of (a) amplitude of tectonic movements, (b) high thermal stress, and (c) convective supply of the matter (and heat) from the mantle. No qualitative distinctions are recorded, however, and the quantitative advantage belongs to the passive margins. The oil and gas generation is occurring in both the active and passive margins, and the difference in its intensity is insufficient to cause any apparent varieties.

The taphrogene is the major oil- and gas-producing complex of the passive margins, whereas for the active margins, it is the riftogene complex (wherever the rifts are established). Their similarity is apparently due to the way both complexes form: accumulation occurred after the pronounced tectonic movements. The advantage of the plate margins becomes obvious for the larger taxons, i.e., continents and oceans. The major hydrocarbon reserves are associated with the continental margins and shelves. The second in importance are the central continental areas. The central oceanic depressions have low potential.

Brod (1947) introduced a theory that petroliferous basins are associated with stable subsidence. Tectonics determines the structure of basin with accumulations forming within the structural traps. The tectonic processes (oscillating movements and lateral stresses) also control the facies of the sedimentary sequences and the location of stratigraphic and lithologic traps. Until now, not much attention was devoted to the uplifting movement occurring against the background of general subsidence and its accompanying oscillations. Indeed, the uplifting movement constitutes a force that creates positive structures and gives rise to the changes in the pressure and temperature, which are major motivators for the fluid migration.

The origin of a sedimentary basin, its depositional environments, and its tectonic evolution affects its oil and gas potential.

As far the continents are concerned, petroleum geologists are interested in the sedimentary basins of (a) internal and marginal platform (plate) areas, (b) foredeeps, and (c) intermontane troughs. The folded zones are of interest wherever they are thrust over the platform (plate) margins and wherever the oil and gas accumulations are discovered underneath them (e.g., Rocky Mountains and Carpathians), or assumed to be beneath them (e.g., Urals, Trans-Caucasus and Himalayas); also in intermontane troughs.

Common feature of the large sedimentary basins underneath the World Ocean is the emergence and evolution over the oceanic or transitional type crust. This affected the tectonic evolution of the basins, tectonic movements, and the sediment cover, the very nature of which is due to tectonogenesis. Another characteristic of such basins is the formation of their sediment fill in deep basins. On the shelf and in the marginal sea basins the depths are within 1–2.5 km. Over the rest of the World Ocean the depth is, on average, 4–4.5 km, which rarely decreases to 1–2 km.

Provenance areas of clastic sediments were relatively close to the shelf and marginal sea basins, whereas the other sediment accumulation areas are hundreds and even thousands of kilometers away from the source. This pattern may be broken outside the shelf area only by turbid flows of major rivers. Rate of deposition and the total thickness of the sediments significantly decrease from the marginal to the central parts of the ocean. The bulk of organic matter is deposited over the marginal zones. With increasing distance from the marginal zone, the amount of organic matter drastically declines. It enters the sediments in a significantly altered form due to long travel. Finally, common to all oceanic basins is a total absence of aerodynamic weathering.

The conditions for the formation of clastic reservoir rocks are quite favorable in the oceanic sedimentary basins. A high pore pressure due to the high water column prevents compaction of deposits. Thus, good reservoir-rock properties can be preserved before the secondary cementation processes. It is well known that the "marine" reservoir rocks are superior to the "continental" ones.

If marine carbonates are sufficiently compacted (near-shore environment; shelf; some intraoceanic highs) and in the presence of water movement carbonate reservoir rocks can often form due to erosion. Fractured reservoirs may occur only in rocks that reached a certain degree of rigidity.

Compaction can occur in the sediments of the shelf and marginal seas; also in some exceptional situations in other portions of the World Ocean. The latter can involve the uplift resulting in an increased compaction.

The formation of the seals (caprocks) is a somewhat more involved issue. Argillaceous caprocks form only if sediments are sufficiently compacted, which is unlikely when the pore pressure is high. That is why numerous wells drilled in the World Ocean encountered only uncompacted sediments. The compacted deposits forming caprocks are only found over the shelves, within marginal seas and, sometimes, over the continental slope. Under favorable depositional conditions in a specific area, the formation of seals from evaporites also requires some compaction. Seals may form in the upper sediment section also due to gas hydrates. Although gas hydrates were discovered in many locations of the World Ocean, hydrocarbon accumulations were found underneath these seals. Thus, the oceanic environment is favorable for the formation of reservoir rocks, whereas the conditions for the formations of seals are possible only within the ocean's margins.

Organic matter introduced into the water of oceans was deposited mostly in the oceanic margins. Any organic matter and hydrocarbons in the internal basins would be formed at the expense of biologic resources. The formation of hydrocarbon accumulations, however, would be problematic. The reason for this statement is that prior to the sediment compaction, the avenues for the vertical migration in those sediments will prevail over the lateral migration, and the dispersion processes in the water medium will prevail over the accumulation processes.

In conclusion, the World Ocean should not be included as the area of vast undiscovered oil and gas reserves. Relatively high potential may be expected only within about 15% of the World Ocean area (marginal zones), whereas interoceanic basins have low to zero potential.

Olenin (1984) presented a review of the definitions of “oil and gas province” term. Mirchink et al. (1976) defined a petroliferous province as an oil and gas basin or the association of adjacent basins, the structural position and tectonic evolution of which were controlled by the same major structural element of the Earth’s crust. This term (petroliferous province) can be considered equivalent to “geologic province” with oil and gas fields.

9.2. HYDROCARBON EXPULSION (“PRIMARY MIGRATION”), HETEROGENEITY OF THE MEDIUM, DISSOLUTION IN WATER AND GAS, AND DIFFUSION

The formation of hydrocarbon accumulations occurs in the process of migration of hydrocarbons. K. P. Kalitskiy (in: Eremenko and Chilingar, 1996) proposed an idea of the *in situ* formation of oil and gas accumulations. This idea was soon rejected due to the absence of substances that would be able, after their transformation, to form an oil accumulation within the original volume. Thus, accepting that concentration (gathering) of hydrocarbons was needed to form accumulations, the petroleum geologists turned their attention to finding out which area, or volume, would be involved in such migration. Usually, the energy-related side of the issue remained ignored.

Starting with Illing (1934), it is believed that migration process includes an independent stage: the expulsion (“primary migration”). The expulsion is a detachment of most volatile components from organic matter and mineral matter and their movement within the poorly permeable source rocks.

The secondary migration involves the movement of oil and gas in permeable rocks through pores and fractures. In this case, displacement of matter is governed by the laws of mechanics, whereas the role of the law of the matter transfer during the expulsion processes is unclear. The detachment of newly-formed molecules from the organic matter occurs at the molecular level and is governed by the laws of molecular physics.

Where and how does that quantum leap occur from the molecular level to the level of matter subjected to the laws of mechanics? The dissipation of newly-formed molecules may occur spontaneously, due to the internal energy of the changing matter. The temperature will accelerate the process. On the one hand, it will enable the breakage of the bonds between the newly-formed molecules and organic matter. Also, by increasing the unencumbered run of the molecules, it will help their distancing from the organic matter.

Can we call these molecules detached from organic matter (mostly not hydrocarbons) oil? Oil is a complex chemical mixture. Its components, mostly hydrocarbons, continuously interact between themselves and with the surrounding medium. Their specificity is defined by their common occurrence in the same matter.

In order to gather the individual molecules into a single mass, some additional energy must be applied. What kind of energy is it? Unfortunately, there is no clear answer to this question. In 1950, Brod and Eremenko proposed that the mobile hydrocarbon and non-hydrocarbon substances that form in the rocks migrate into

traps, accumulate in them through physicochemical interactions with one another, and form a complex chemical mixture called oil. Unfortunately, this idea does not answer the above question of the energy source and the mechanism of its action.

The concept of primary migration of oil (expulsion) as a result of the compaction was widely accepted for a long time. Gubkin (1932) suggested that oil left the source rock together with the last portions of the squeezed-out water. Thus, he suggested that oil was generated in the source rocks. Early, in the course of lithogenesis, while the organic matter has not yet been converted into hydrocarbons, mostly water was squeezed out. At the initial stage of compaction, the squeezed-out water moved mostly up, toward the lower pressure zone.

Koichi et al. (1985), in order to investigate the primary migration of oil, have compacted the Na-montmorillonite clay (mixed with seawater and crude oil) for 25 days under a pressure of 1000 kg/cm^2 and a temperature of 60°C . The amount of expelled liquid from the clay was large at the early stage of compaction and decreased gradually as compaction progressed. The proportion of oil in the expelled liquid gradually increased with increasing time of compaction. Porosity of the compacted sample decreased from 81% of original clay to $\approx 26\%$.

As the sediments compact and become rocks, the direction of the squeezed-out fluid flow changes. Inasmuch as the permeability is usually higher in a lateral direction, the main fluid flow also occurs in that direction. Thus, the main fluid flow in a basin is directed toward the basin flanks. Upon compaction, because of low permeability, the flow of fluids is hindered in clays with formation of abnormally high formation pressure (AHFP).

Compaction of sediments was studied by many scientists, e.g., Rieke and Chilingarian (1974), Chilingarian and Wolf (1975, 1976), Buryakovsky (1985a,b), Beletskaya (1990), and Buryakovsky et al. (1991). It was established that the clay structure changes upon losing water, which is especially noticeable in the case of montmorillonite. During diagenesis, the montmorillonite is transformed into illite (Powers, 1967). Its structure drastically changes and it loses up to 50% of its mineral mass. As a result, earlier bonded interlayer water is released as free water resulting in additional fracture porosity. Thus, the avenues for the primary migration are created. In addition, the additional water for expelling organic matter transformation products becomes available.

The compaction and consolidation of carbonate oozes are accompanied by crystallization and, often, with appearance of numerous microfractures. Upon lithification, the mobile substances within the deposit in part become a component of the rocks, and in part acquire the ability to move. Upon dolomitization ($\text{Mg}^{2+} + 2\text{CaCO}_3 \rightarrow \text{MgCa}(\text{CO}_3)_2 + \text{Ca}^{2+}$), up to 13.1% porosity (mainly rhombohedral with some microfractures) can form, creating further avenues for migration (see Chilingarian et al., 1992, 1996).

Transformation of the montmorillonite to illite and the compaction of the other clays are controlled by the temperature, composition of the interstitial fluids (e.g., presence or absence of potassium ion), and permeability changes in the section.

Temperature increases with the subsidence of rocks (whether carbonate or clastic). Coefficient of temperature expansion is different for different rocks, water, oil, and

gas. It is much greater for oil and gas than it is for the rocks. In addition, the physical and chemical properties of mobile substances change with increasing temperature. Their viscosity declines (except for gases) and they can evaporate, completely or in part.

Thus, these changes promote migration. Kh. Watte (in: Eremenko and Chilingar, 1996) believed that the major force behind the oil expulsion is the temperature changes in the Earth’s crust. According to him, the primary migration occurs by way of hydrocarbon transfer by water (as an emulsion?), and a combination of adsorption and diffusion due to temperature gradient. The issue of the nature of a medium is highly important when looking for the external energy sources for the migration and accumulation of the products of transformation of organic matter.

The issue of physical and geochemical uniformity of rocks is worth discussing. It is especially important with respect to those sequences that are believed to be oil and gas source rocks. Most authors, whether in an obscure or unambiguous form, base their conclusions on a concept of uniform distribution of source organic matter in rocks. The rock sequence, at least within the oil and gas generation zone, is more or less uniform and the geochemical environment is maintained within a rigid range with the same heat flow. Thus, there is a vertical zonation of catagenesis by temperature intervals, with uniform compaction of the source-rock sediments. These assumptions, which are based on the average organic matter content and on its average transformation, are utilized in genetic method of the evaluation of prognosticated reserves. But, is this correct? To answer this question, one must review the type of changes in the major physical and geochemical parameters in a source rock.

9.2.1. Overburden Pressure

The overburden pressure is determined by the thickness of overburden and the rock density, both of which vary in any oil and gas basin. Even if smaller areas within a source-rock sequence are selected, the above variables will change substantially even if the surface topography is ideally plain. This occurs due to the fact that:

- (1) A thick source-rock sequence always includes lithofacies and thickness changes of component formations. The boundaries of these formations do not have to coincide with the hydrocarbon-generation zone boundaries (Nazarkin, 1979).
- (2) The source-rock sediments are always deformed, which causes differences in lithostatic pressure along them. Deformed sediments will respond differently to the “arch effect” (Poisson’s ratio). Thus, the overburden pressure (pressure potential) will differ within a source-rock sequence.

9.2.2. Pore Pressure

Source rocks usually have low permeability and usually display the “elision” regime with AHFP (see Chapter 3). The magnitude of pore pressure depends on the

difference between the increase in the rate of fluid pressure increase and the rate of relaxation. Both rates can vary significantly within the source-rock sequence. For instance, the former one is determined by the (1) overburden pressure, (2) formation temperature, (3) volume of the released interlayer water, mainly as a result of montmorillonite-to-illite transformation, (4) volume of newly-formed substances (due to organic matter transformations), and (5) osmotic pressure, etc. The rate of relaxation, on the other hand, depends mainly on the permeability (because it is determined by the diffusion and effusion phenomena). Thus, the variation in pore pressure potential arises within a source-rock sequence. This variation is especially pronounced in a heterogeneous source rock.

9.2.3. *Rock Compaction*

Rock compaction occurs mainly as a result of increasing effective pressure, which is equal to the difference between the total overburden pressure and the pore (fluid) pressure. Variable nature of these parameters has been discussed earlier (see Section 3.1). The non-uniform nature of source-rock compaction, with all ensuing consequences, is obvious.

9.2.4. *Temperature*

The endogenous heat flow undoubtedly affects the rock–water–organic matter system. Smirnov (1980) mentioned three types of the heat-flow anomalies: mantle, crustal, and near-surface ones. The latter two types may be associated with the occurrence of non-stationary heat sources in the Earth's crust and the sedimentary cover (Sergiyenko, 1995; Nazarkin, 1994). These authors described in detail the arising non-uniformity and unsteadiness of the heating of sedimentary rocks. It is sufficient to emphasize here the emerging variation in the potentials of temperature within the sedimentary rocks (including source rocks).

9.2.5. *Geochemical Non-Uniformity*

Geochemical heterogeneity is caused not only by the original deposition of chemically diverse sediments, but also by the combined effect of diagenetic and catagenetic alterations. The recrystallization processes, the emergence of new minerals, and the disappearance of the other ones are accompanied by appreciable changes in temperature and pressure. These changes occur because endothermic and exothermic processes may be happening at the same time within different parts of the system. Just the geochemical heterogeneity alone can create a very strained geochemical environment (see Section 3.1) within a sedimentary sequence (especially within the source rocks). These phenomena increase in sedimentary sequences enriched in the organic matter. Field data indicate (see Chapter 7) that the quality and quantity of organic matter may significantly fluctuate even within a single sample. The largest quantitative fluctuations of organic matter (both organic carbon and bitumen) are observed within the oil and gas windows.

The above discussion shows that during lithogenesis the source rocks reside in an extremely stressed energy state. Such a system tends to achieve the state of equilibrium. The energy is redistributed within the system (source rock) and is transported (along with the fluids) to the adjacent beds with a lower potential energy level. This results in the leveling of the energy non-uniformity. The process is unavoidably accompanied by folding and faulting.

Thus, a particle of organic matter, with all the internal energy accumulated within it, gets into a sedimentary sequence, which is in a highly stressed-energy state. In the process, the organic matter is altered, first of all by way of losing various mobile components, including relic hydrocarbons.

The detachment of individual molecules from the organic matter may be initiated by various energy potentials. An excellent monograph on the primary oil migration was published by Beletskaya (1990). The study is based on the analysis of data in the literature and on the laboratory experiments. Beletskaya concluded (p. 277) that the following factors cause the detachment of microoil from the source organic matter: (a) desorption of the reservoir water, gas and hydrocarbons; (b) temperature increase due to the sediment burial or due to endothermic processes in sediments; and (c) possibly, diffusion processes.

Actually, the number of reasons may be greater than that. Beletskaya (1990) treats organic matter as a passive object, whereas in fact it is one of the most active, energy-saturated components of the system (see Chapter 7). To achieve the energy equilibrium, it can expel the “extra” particles or molecules and can cause exothermic reactions.

The compaction of sediments with the included organic matter begins at the stage of diagenesis and continues during catagenesis. The compaction caused by the increased pressure and changes in the structure of the substance drastically decrease the surface of particles and, hence, their surface to energy. A decrease in the surface energy makes it easier for particles (and molecules) to be detached from the “mother” (source) substance. If a water or hydrocarbon film covered the surface of the solid substance, such film may have moved either to the adjacent particle with higher surface energy or to the pore space. In the latter case, if hydrocarbons were present, they may form a free phase (liquid or gas). Obviously, hydrophilic or hydrophobic properties of the surfaces, or changes thereof, would affect the course of the process.

Thus, individual organic matter components detaching from the source matter may be considered as the first stage of expulsion process. The following second stage would be the displacement (migration) of the released matter. The third stage is the primary accumulation (i.e., the formation of a substance that is moving in the pores according to the law of hydrodynamics). The nature and direction of the second and third stages would depend of the physical state of migrating substance, which will determine the physical or physicochemical processes providing for the displacement of substance and the selection of the avenue of migration.

Hydrocarbon molecules detached from the source matter get into the surrounding water and form a true (molecular) solution. The solubility of gas and liquid hydrocarbons in water have been extensively studied (e.g., Chekalyuk and Filos,

1977; Chekalyuk, 1986; Parker et al., 1986; Simonenko, 1988; Beletskaya, 1990; Sariapo, 1993). The solubility was established for most mixtures (mostly binary, however). It is important to mention that the high-molecular-weight compounds found in crude oils are poorly soluble in water. The increase in solubility of liquid hydrocarbons in water with increasing temperature becomes appreciable only above 160–180°C. Separation of liquid hydrocarbons from solution may occur when temperature declines or the water salinity increases greatly.

The molecular solubility may play a significant role in the expulsion (and migration) process only when the rocks are subjected to high temperature and pressure ($T > 120\text{--}180^\circ\text{C}$, $p > 20\text{ MPa}$). Water-soluble hydrocarbons can travel together with water for a long distance and time. They can be “salted-out” only after the solubility limit is exceeded. The total saturation of water with hydrocarbons, however, is observed only in the immediate proximity of oil–water interface.

The liquid hydrocarbons are highly soluble in the colloidal-emulsion or micellar form. This solubility is at least one order of magnitude higher than that in the case of true solutions. Beletskaya (1990) stated that:

- (1) Emulsions (water-in-oil) form spontaneously, due to the heat motions of molecules.
- (2) In order for the emulsion to form, there is no need to overcome the micelle-formation critical barrier (enough of surfactants and emulsifiers are present in the dispersed organic matter per se); however, an alkaline environment is required.
- (3) Inverse emulsions (water-in-oil) may form with the asphaltene-type surfactants; such inverse emulsions have the external hydrocarbon phase (hydrophobic), are floating in water, and when moving through rocks are capable of desorbing and dissolving paraffins and asphaltenes. These emulsions are stable over a wide range of pressure and temperature.

The emulsions are electrically charged and electrolytically active. Practically no studies of the interaction between emulsions and both natural and artificial electromagnetic fields have been conducted (Starobinets et al., 1986). The major obstacles for the movement of colloidal solutions are the size of the particles (0.1–0.001 μm) and the electrostatic difficulty for the movement of negatively charged particles (the surfaces of clays are negatively charged). According to Eremenko and Chilingar (1996), the particles move unobstructed through the pores where the pore throat (or canal) diameter is at least three times greater than the particle size. When micelles form, the size of the resulting globules may be comparable or even greater than the diameter of pore throats. At the same time, as the water-in-oil emulsions, the gas-in-water emulsions can form.

Demulsification may occur upon changes in the water composition and pH and when the emulsifier is catagenetically altered. The break-up of an emulsion may cause the primary accumulation even within the source rocks. Owing to the low permeability of rocks to emulsion, the latter can serve as a barrier.

The “submelted” water layers (see Chapter 4) are affected by the surface forces and have different properties compared with free water. The difference is first of all in their higher solvating capability and their lower polarity. According to

A. M. Bloch (in: Eremenko and Chilingar, 1996) and Simonenko (1988), such water in limited pore space may create superconcentrated solutions (similar to melts) that become unstable upon transition to larger pore space. When these solutions enter such pore space with weak surface forces, hydrocarbons and other dissolved components are “salted-out”. The presence of elevated ore concentrations at the contact of clays and sands may serve as an indirect confirmation of this phenomenon.

The above explanation, which needs an experimental confirmation, may explain the primary migration and accumulation of oil. Tsarev (1978) suggested that film of microoil forms at the boundary of residual (irreducible) and “submelted” water. The “submelted” water layers, together with the microoil, have high mobility and will be squeezed out of the rock first.

Kruglikov (1976) proposed a somewhat different mechanism of the film-type migration of hydrocarbons. According to him, the forming gas bubbles, which are enshrouded with an oil film, can migrate. The mobility of such an emulsion within the rock may be quite difficult because of the similar size of gas bubbles (with an oil film) and narrow canals.

9.2.6. Dissolution in Compressed Gases (See Retrograde Dissolution in Chapter 6)

A compressed free hydrocarbon gas, especially in the presence of methane homologs and CO₂, is capable of extracting hydrocarbons and other oil-like substances from the organic matter (see e.g., Zhuze, 1986; Beletskaya, 1990). According to Beletskaya, at a depth of about 1 km, a cubic meter of gas (a mixture of methane + methane homologs + CO₂ corrected to standard conditions) in a near-static environment can dissolve 0.0012 m³ of oil. This shows that the primary migration of oil is quite possible in the presence of free gas.

Material balance calculations by Neruchev (1979) showed that the gas, released as a result of decomposition of organic matter, can dissolve up to 40% of the generated bitumen. Taking into account the phase composition of fluids migrating toward an accumulation, the quantitative ratios and the solubility of released gases in water, Neruchev concluded that only when the organic matter content in rocks exceeds 2%, can some CO₂ and methane form an independent phase and transport liquid hydrocarbons. Therefore, this primary migration mechanism is possible when the organic matter content in a rock exceeds 2%, but is an unlikely scenario for all oil accumulations.

9.2.7. Diffusion

Dissipation of energy and matter is a common phenomenon in the Earth's crust. This phenomenon definitely occurs in the process of primary migration of oil, but cannot in principle explain the primary and, even more so, the secondary hydrocarbon accumulation because of its positive entropic nature (concentration

equalization). Quantitatively, diffusion can be described by Fick's law for gases:

$$Q = \frac{wAb(C_1 - C_2)}{h}$$

where Q = the volumetric rate of diffusion, w = the diffusion coefficient, A = the cross-sectional area, b = the solubility or sorption coefficient, and h = the bed thickness. The $b(C_1 - C_2)/h$ is called the gradient of concentration.

At least two indirect ways for diffusion to participate in the formation of hydrocarbon accumulations have been proposed:

1. The water within a source rock is being saturated with liquid hydrocarbons. This water, upon moving into a reservoir rock, with a different thermodynamic and geochemical environment, releases the dissolved hydrocarbons. The dissolution is possible if the water is (1) alkaline, (2) CO₂-saturated, and (3) heated to 120–150°C. A high concentration of hydrocarbons within the source rocks and their ability to saturate the water at lower temperatures (<120–150°C) are in doubt. Besides, in such a case the hydrocarbon-saturated water would be observed in the oil and gas basins, especially next to the source rocks, which is not the case.
2. Thermal diffusion (Geodekian et al., 1984) results in fractionation of the diffusion flow and in the concentration of heavier hydrocarbons near the cooler edge. In the opinion of the writers, however, the thermal diffusion is in effect a superposition of different phenomena: the thermal fractionation (separation) and diffusive equalization of fractions. Thus, the diffusion proper equalizes the composition. As far as the thermal fractionation is concerned, it is widely used in refinery operations.

9.3. PRIMARY ACCUMULATION AND FREE PHASE MIGRATION ("SECONDARY MIGRATION")

A concept of the active liquid oil migration from the source rocks was extensively discussed. It is not simply the squeezing-out of separate oil droplets, which is a complex process in a natural environment. The concept assumes the release of liquid phase as streams (Savchenko, 1977). Through this migration mechanism the accumulation can occur already within the source rocks (possibly via the film mechanism as described above). The major objection to this migration mechanism is the absence in nature of source rocks (even assumed ones) with a high concentration of residual oil.

Shklovskiy (in: Eremenko and Chilingar, 1996) developed a flow model for an infinite cluster. Experimental studies by Efros (1982) indicated that the flow threshold exists at about 15–20% of residual oil saturation. If oil and water are present in a good reservoir rock, the relative permeability to oil tends to zero at the oil saturation of 15–25% (depending on the oil and water viscosity under reservoir conditions). Even in very good reservoir rocks, at least 25% of the oil is left behind after production. In poorly permeable rocks (usually, the assumed source rocks belong in this group) the residual oil saturation is over 70%.

Magara (1981, 1982) estimated that the oil saturation should be at least 14.5% in order for a continuous stream of oil to form in a rock. Cartmill (1979) proposed that the minute oil droplets flocculate into clusters coated with water. If this migration mechanism was operative, the oil might not have left any traces in the rock. Whether or not the oil is able to move as such emulsions has not yet been studied. It is not clear if it would be possible for such "clusters" to get through the pore throats and canals. The stability of such emulsions under reservoir conditions is also unknown (this is important for the primary accumulation).

Dickey (1975) proposed that a substantial volume of oil could migrate through a hydrophobic rock. According to him, in such a case, the concentration barrier for the phase migration of the oil may be as low as 1%. Actually, the rock does not have to be hydrophobic. It must contain conductive channels lined with hydrophobic organic substances (such as, residual asphaltenes) or minerals (sulfur, graphite, talcum, and/or sulfides).

The concentration barrier for the oil movement may actually be lowered from 25% (at uniform saturation) to 1% (at non-uniform saturation). Eremenko (1985) proposed a non-uniform spreading of the organic matter transformation within rocks and non-uniform distribution of the products of this transformation. Within each limited volume of rock containing organic matter, energy redistribution occurs in the rock–water–organic matter system due to external and internal factors. High-energy compounds formed as a result begin to move toward the areas with lower energy or toward the adjacent reservoir rocks. This movement occurs most likely according to the laws of film-type migration. The process develops with an increase in the volume of organic matter (due to external energy). This results in the appearance, movement and superposition of molecular films one over the other. As the number of film layers increases, their molecular connections with the rock and the source organic matter decreases. Eventually, they blend together and form a single substance. Probably, Klubova (1975) observed such phenomena under the microscope.

Other mechanisms of filling of fractures with fluids are possible. For instance, a substance formed in pores may be squeezed out into a fracture. The process is non-uniform in time and space. The degree of organic matter transformation at different parts of the same sequence, especially if it is heterogeneous, differs. Non-uniformity of primary accumulation process results in a sporadic distribution of primary accumulations (streams) of hydrocarbons obeying the laws of mechanics.

The Shklovsky's model (in: Eremenko and Chilingar, 1996) cannot be applied in this case because there is no indefinite cluster and there is a directional change in time. The saturation needed for the movement of a continuous phase (a stream) may be reached in just a few channels (canals). The average saturation in rock may be actually very low, just a fraction of one percent. In the proposed concept, the non-uniformity of the medium, the processes occurring within the medium, and the energy stress of the rock sequence are essential factors of the primary hydrocarbon migration and accumulation.

From this position, a uniform organic matter accumulation within the uniform sequences (such as the Maicopian and Bazhenov formations in Russia and the Green

River Formation of the United States) is an unfavorable factor for the formation of hydrocarbons. Still, the hydrocarbon accumulations form because the uniformity of these sequences and of their organic matter content is quite relative. However, the accumulations turn out to be small compared with the huge volume of organic matter concentrated in such sequences. In such cases, the bituminous sequences formed in a sedimentary basin can contain relatively small hydrocarbon reserves (relative to the organic matter content in the basin).

All of the above-described primary migration mechanisms can develop in nature and act simultaneously. Relative predominance of a mechanism depends on the specific subsurface temperature and pressure and geochemical environment. Laboratory studies and field observations on the subject should be continued.

The same mechanisms can be operative during the secondary migration phase. Changes in the intercommunication of pores occur during compaction. As a result, part of the pores becomes isolated. As pointed out by Beletskaya (1990) and Nazarkin (1994), organic matter transformation processes in such pores are unique. Organic matter in the closed pores is enriched in all kinds of bitumens low in alkanes. Nazarkin (1994) stated that this is one of the reasons why sequences (such as bazhenites, domanikites, etc.) with abundant isolated pores do not generate large volumes of hydrocarbons.

A heterogeneous sedimentary sequence with alternating reservoir and sealing rocks exhibits differences in energy potentials. The other phenomena prevail in such a case: (1) first of all buoyancy (the Archimedes principle), (2) hydraulic heads, and (3) the elastic forces of fluids and rocks.

Oil and gas migration due to buoyancy force can occur only through fractures or large pores. A number of forces resist the gravity-induced movement of oil and gas. They include (1) friction, (2) interphase friction (caused by motions of oil, gas and water relative to one another), (3) relative permeability, (4) viscosity (or internal friction), and (5) molecular attraction between the rock walls and moving fluids (capillary forces).

Droplets of oil or gas moving through the pores are subject to the Jamin effect¹⁴. In order for a globule (minimum surface) to move through a narrow passage its shape must change. Consequent increase in its surface results in the expenditure of additional energy. The capillary pressure difference Δp (needed for the droplet movement) at the opposite ends of the droplet is equal to

$$\Delta p = \sigma(1/R_1 - 1/R_2) \quad (9.1)$$

where R_1 and R_2 are the radii of curvature of advancing and receding end of gas bubble and σ is the interfacial tension.

Although the Δp may be small for a single bubble, the cumulative resistance of many bubbles may be large. Additional resistance to flow is created by the polymolecular layers of oriented molecules of surface-active components in the oil, which are adsorbed on the rock surface and may be thick (10^{-3} – 10^{-4} cm).

¹⁴Jamin effect is manifested as the restrictive force exerted upon the fluids flowing through narrow passages by successive bubbles of gas.

Buoyancy is more effective in the case of continuous oil and gas body (a stream) rather than in the form of discrete droplets. Two questions arise here:

- (1) What is the possible size of stream?
- (2) What distance can the secondary migration overcome?

The length of the stream (l) depends on the density of oil and water (ρ_o and ρ_w), the inclination angle of the barrier surface (α), and the capillary pressure at the start of movement. Under the hydrostatic conditions (see Chapters 4 and 5),

$$(\rho_o - \rho_w)g \sin \alpha + \Delta p/l = 2\sigma(1/R_1 - 1/R_2) \quad (9.2)$$

Levorsen's (1954) calculations indicate a pronounced effect of buoyancy at a length of 1 and 10 m of the continuous phase.

As far as Question 2 is concerned, three conditions must be met for the secondary migration to occur:

- (1) Enough fluid must be available along the entire length of movement (migration).
- (2) Avenues of migration for this fluid to move must be available.
- (3) Availability of forces that could move the fluid along.

Most petroleum geologists believe that the main (maybe even the only) force that causes the movement of oil and gas is buoyancy (gravitational force). The capillary forces are considered to constitute the main obstacle to the movement (P. Allen and J. Allen, 1993, p. 340).

According to the writers of this book, there are many natural forces that may cause migration of oil and gas. Buoyancy is one of these forces and, quite often, is a dominant one. One has to keep in mind, however, that buoyancy force decreases with increasing depth, as physical properties of oil, gas, and water become closer.

Some hydrocarbon accumulations reach tens and even hundreds of kilometers in length. Thus, the lateral migration (i.e., along the reservoir rock) might have occurred at least along these distances. Mountainous and piedmont areas of the folded regions encountered all over the world contain copious oil and gas shows. The causes for that are twofold: (1) deformed areas include numerous avenues for oil and gas migration (fractures and faults); and (2) these areas are subject to powerful erosion, which exposes oil- and gas-saturated beds at the surface. In such cases, the interreservoir oil and gas migration may be visually estimated to reach at least a few kilometers. Thus, the knowledge of a specific geological scenario is needed to establish the length of secondary migration.

The lateral migration in most cases is limited by the position of the axis of the adjacent depression. The limitations may be associated with obstructions to flow (often, lithological barriers). Vertical migration in most cases is limited by the thickness of oil-saturated formations and by the length of faults. Migration is observed even in such tectonically quiescent regions as West Siberia. According to Kontorovich et al. (1975, p. 589), the vertical migration could have played a certain role in the formation of oil and gas accumulations on the Siberian Plate. Examples include Myldzhinskoye and South Cheremshanskoye fields.

Combination of vertical and lateral migrations is quite possible and the fluids select the most energy-efficient route regardless of its direction. It appears that most energy-efficient avenues are linear. Having once selected a route, the fluids tend to

use it repeatedly, because along this route they experience the least capillary resistance and the least loss of matter (all sorption sites have already been saturated). Along the way, heavier molecules tend to displace the lighter ones from the surfaces of mineral particles, which results in some change in fluid composition.

Any migration along a relatively long distance results in the separation of oil and gas from the oil–gas mixture. (The opposite phenomenon, i.e., mixing of the oil and gas, also occurs in certain cases.) When the migration is dominated by buoyancy, the oil and gas separation is most distinct. This is particularly distinct in the presence of a chain of interconnected traps within a single structural trend. The principle of the “differential entrapment” of oil and gas has been presented simultaneously by Gussow and Maksimov in 1954.

The following relationships may be observed as a result of regional uplift of a reservoir bed with local highs separated by significant lows (Figs. 9.1 and 9.2).

Observations made by Gussow and Maksimov concern possible explanations for the difference in the oil and gas content of adjacent or nearby traps. They suggest that the nature of the hydrocarbons trapped in the reservoirs depends on the proximity of the reservoirs to the source rocks. As oil migrates across basins and encounters a series of traps, the process of differential entrapment becomes operative. The theory states that a trap filled with oil and gas may eventually lose the oil to another trap updip as oil and gas continue to migrate into the area. In Fig. 9.1, during stage 1, trap A is an oil reservoir with a free gas. After trap A is filled and additional oil cannot enter the trap, it spills updip to trap B, which contains oil only. In Fig. 9.1, during stage 1, trap A is an oil reservoir with a free gas. After trap A is filled and additional oil cannot enter the trap, it spills updip to trap B, which contains oil only.

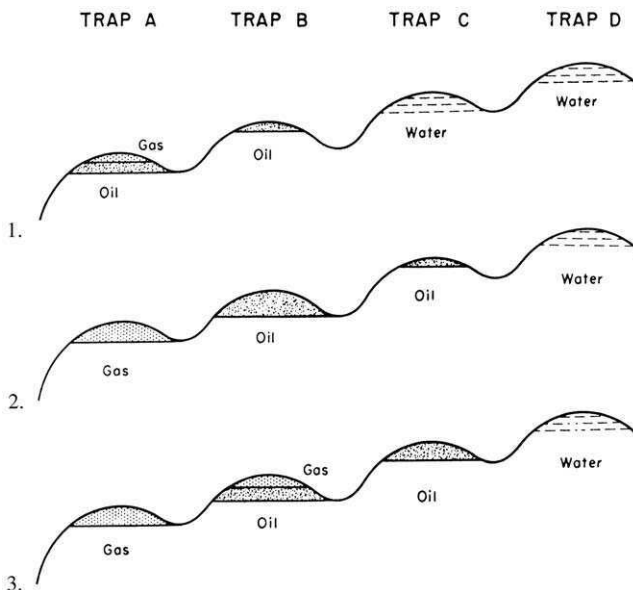

Fig. 9.1. Theory of differential entrapment: different stages in the migration and accumulation of oil and gas in interconnected traps (after Gussow, 1968; courtesy of AIME).

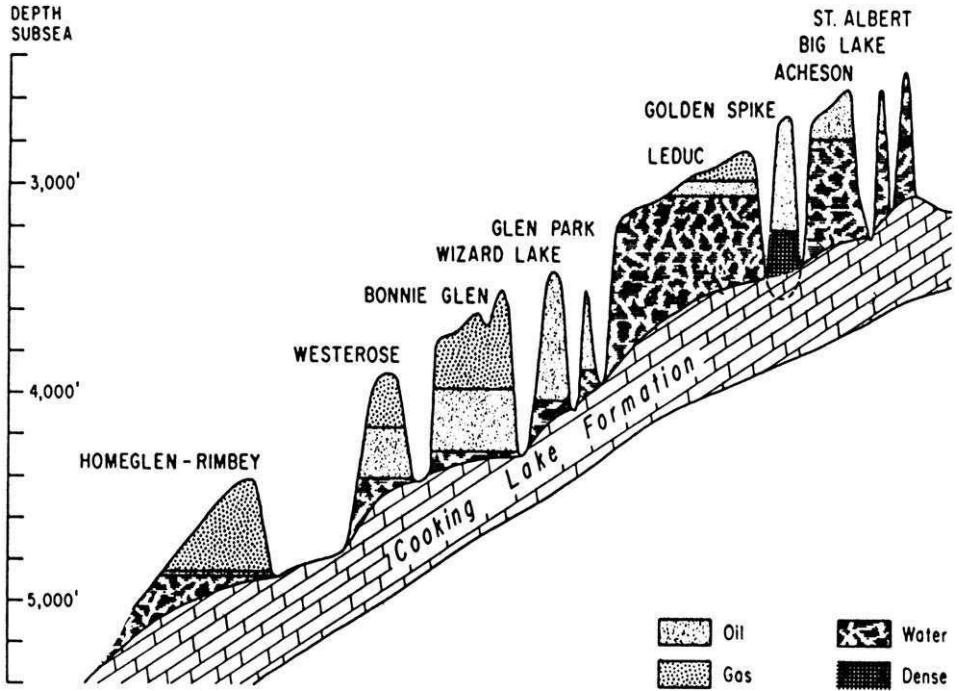

Fig. 9.2. Profile of the Acheson-Homeglen-Rimbey-Leduc reef trend (after Horsefield, 1962; Hnatyuk and Martinelli, 1967; courtesy of Pet. Soc. of CIM).

The migrating gas, however, will continue to be trapped in trap A during stage 1. Traps C and D contain only water. In stage 2, trap A is completely filled with gas and all the oil has been displaced to trap B, which is completely filled with oil. Oil is starting to spill out to trap C. Trap D still contains only water. In stage 3, trap A remained a gas reservoir and both oil and gas are bypassing it. Trap B now has a gas cap and oil is bypassing it; oil is also expelled as the gas cap expanded. Trap C is now filled with oil but still has no gas cap. Trap D is filled with water.

Gussow (1968) cited the oil and gas accumulations in the Leduc reefs on the Acheson-Homeglen-Rimbey trend, Alberta, Canada, as a general illustration of this process (Fig. 9.2). Homeglen-Rimbey is an oil reservoir with a very large gas cap. Westeros South, immediately updip, is all gas. Farther up the trend, Westeros, Bonnie Glen D-38, and Bonnie Glen D-3A are oil pools with free gas cap. Next come Wizard Lake and Glen Park, oil pools without gas caps, and finally Leduc-Woodbend, Yekau Lake, and Acheson, which have gas caps. The presence of gas caps in the last three reservoirs, even though they are updip from the two pools that do not have gas caps, can be explained by the large difference in depth of burial between the two areas, which is approximately equal to 1000 ft. The lower pressure in the shallower reservoirs allowed some of the gas to come out of solution and form a gas cap.

The above-described pattern is typical of the regions where reservoir pressure in oil accumulations is equal to the saturation pressure even at the level of the lowermost trap. If the gas-saturation pressure in the lowermost accumulations is lower than the reservoir pressure, there is no separation of oil and gas in these accumulations. According to Neruchev (in: Eremenko and Chilingar, 1996), the free gas phase can form only when the organic matter concentration is sufficiently high. The lower traps (Fig. 9.3) will be filled with oil and have a low saturation pressure. As migration proceeds along the series of interconnected traps, the saturation pressure deficit will decrease until it disappears. That is when gas is released out of the solution and either forms gas caps or straight gas accumulations, thereby squeezing oil into the higher located traps (see Fig. 9.3). The case (a) is a special version of a more general case (b).

Some examples of differential entrapment were published by Savchenko (1952), Maksimov (1954, 1962), Samedov and Buryakovsky (1962), Fyodorov (1962), Buryakovsky (1973, 1974), and Bagir-zadeh et al. (1974).

The above-described phenomenon is just a simplification. The process in nature is more complex and depends on the geologic scenario and changes in time. Various factors may cause substantial changes, which include (1) time of trap formation, (2) changes in the regional dip, (3) depth of burial and associated formation pressure and temperature, and (4) exposure of the reservoir at the surface. Distribution of oil and gas accumulations according to the principle of differential entrapment is observed in many tectonic zones of the world.

Changes in the amount or direction of the regional dip occur in many oil and gas provinces. They can cause a considerable redistribution of oil and gas accumulations. Some traps may partially or completely open and consequently lose their hydrocarbons.

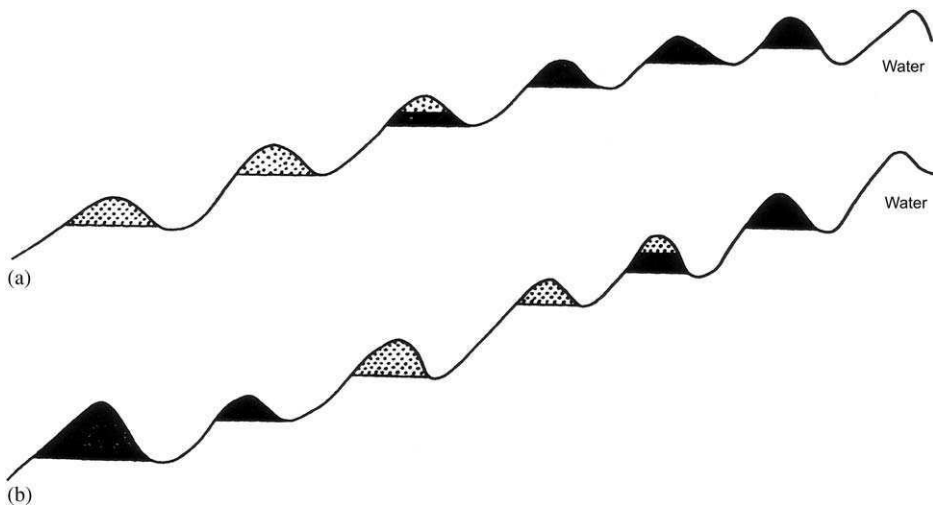

Fig. 9.3. Conceptual diagram of selective retention of oil and gas in a series of interconnected traps (after Maksimov et al., 1981).

At the first stage of formation of accumulations, the traps at great depth, in the way of migrating hydrocarbons, are filled with gas and oil. The traps higher up the slope are filled with water. If the regional structure changes later, the uplifted traps may contain large hydrocarbon reserves. Peripheral accumulations may be totally destroyed in the case of very significant uplifts. In the case of favorable scenario, however, large oil fields or bitumen deposits could form (e.g. Devonian reservoirs in the Romashkino Field in Russia and the Athabasca bitumens in Canada).

The density differentiation occurs easier in the moving fluids. Individual oil or gas droplets float to the water surface, coalesce and, if the conditions are favorable, form a large mass of hydrocarbons. The water is capable of displacing this mass by the pressure of the hydraulic head.

It is important to elaborate here on the tilted water–oil contacts. Capillary pressure curves, along with relative permeability curves, can be employed to explain tilted water table conditions in the absence of hydrodynamic causes. In the hypothetical example given by Arps (1964) in Fig. 9.4, the porosity and the permeability of the formation decrease from left to right with resulting increase in the transition zone thickness, as shown by the capillary pressure curves.

Some generalization of spatial pattern of changes in the properties of fluids (first of all, density) was proposed by Buryakovsky (1973, 1974). The space pattern of changes may be subdivided into the changes of the first and second order.

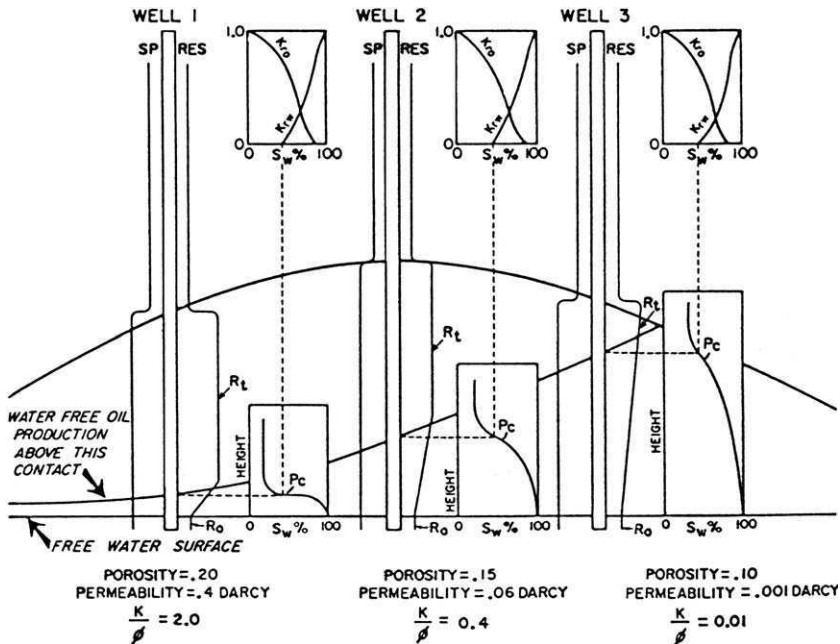

Fig. 9.4. Tilted oil–water contacts with lateral variation in rock characteristics (after Arps, 1964, Fig. 3; courtesy of AAPG).

First-order pattern within the fields, grouped together on the basis of common geotectonic conditions, include the following changes based on the decrease in scale (Fig. 9.5)

- I. Regional, with transition from trap to trap along the anticlinal trend.
- II. Local, through the stratigraphic section, with change in depth of a stratigraphic unit.
- III. Interreservoir, dependent on change in the topographic depth of the individual reservoir. During the process of field development and production, this pattern has been associated with changes in the properties of oil and water with time.

Second-order patterns, also having a definite regularity, may be qualitatively or quantitatively depend on several factors including (1) lithology, (2) reservoir-rock properties, (3) total salinity and ionic composition of the formation water, (4) migration of the subsurface fluids, and (5) basin hydrodynamics.

A sedimentary basin usually includes several hydrodynamic systems. Each individual reservoir can have its own hydrodynamic system. The formation of such systems (either artesian or "elision") occurs independent of each other, and they may have independent reservoir pressure distributions.

As long as there is a pressure difference, there is a possibility of cross-flow from one system to the next. This, however, requires avenues of migration. The most common avenue for migration is a fault plane, although movement can also occur through "windows" in the seals separating reservoirs. If such avenues of migration are wide enough and long-lasting, the reservoirs may form a single complex hydrodynamic system. The cross-flows from one system to the next one with the possible formation (neof ormation) of the hydrocarbon accumulations are

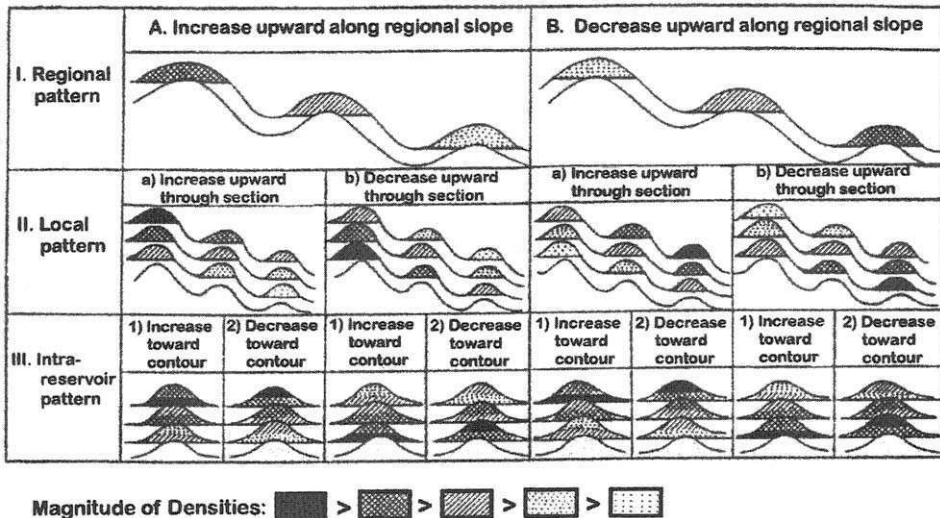

Fig. 9.5. Classification of patterns of changes in the crude oil properties on the basis of crude oil density (after Buryakovskiy, 1974).

determined by the pressure gradients. Thus, the direction of flow may be either upward or downward.

If two reservoirs are separated by a third one, with a higher or lower reservoir pressure, the third reservoir hampers the cross-flow between the first two reservoirs. However, it is possible to bypass the overpressured reservoir (AHFP) using the concept developed by Eremenko (1961) which he called "the piston mechanism". When a fracture is formed, vacuum is created and the fluids rush into the fracture. Inasmuch as the fracture has a higher permeability than the bed with AHFP, the fluids will flow along the fracture to reservoir with higher permeability, thus bypassing the lower-permeability bed with AHFP. A similar concept was presented later by Chepak (1984) and Solovyev (1986). This concept is not applicable to a bed with ALFP (abnormally-low formation pressure), because such a bed is a receptacle for the fluids. Thus, it will hinder the fluid movement in all directions.

The independent creation and existence of hydrodynamic systems may cause a situation when the adjacent reservoirs in different parts of a basin exchange fluids in the opposite directions. Elastic energy accumulated by the fluids (expressed in the form of AHFP) cause fluid movements. This is especially evident in block-faulted reservoirs. In such a situation, the fluids elastically compressed into a single phase can cause their own movement. The separation of this phase into different phases may occur later within a trap.

The diverse geological processes are not always mutually exclusive. These processes and the associated forces often appear simultaneously within a single geologic space. That is why it is very difficult to distinguish individual processes and forces giving rise to them in a particular situation.

For example, in the process of formation of accumulations, buoyancy is most active in the upper part of the Earth's crust and within steeply dipping avenues of migration (fractured zones, faults). With increasing depth, because the differences in the physical properties of oil, gas and water tend to decrease, the action of buoyancy declines up to a total disappearance (e.g., in "critical type" accumulations). The capillary forces, which can either obstruct or cause migration ("wick" effect, film migration), increases to a depth of 700–1,000 m and then decline to a total disappearance in "critical type" accumulations. Elastic forces, which are insignificant or absent in sediments, increase upon burial and are predominant in the "critical type" accumulations. Pressure and temperature gradients in the sediments increase with increasing energy stress, i.e., with depth and, especially, with increasing tectonic stress.

Mutual solubility of fluids, as a factor promoting migration, significantly varies with increasing temperature and pressure: first, a rather high solubility of hydrocarbon gases in water and oil; then, an increased mutual solubility of gas and oil; and lastly, almost complete mutual solubility of gas, oil and water in "critical type" accumulations.

The role of sorption and hydrophilic or hydrophobic properties of rocks decreases with increasing temperature (i.e., depth). The role of AHFP in the migration processes (either constructive or obstructive) increases from a depth of 300–500 m up to the emergence of energy-differentiated block-faulted reservoirs. Down the section,

within the metamorphic basement, which is fractured and possibly connected at a distance with the surface (through an erosion surface or fractures), AHFP can disappear.

Hydrocarbon accumulation begins to form at a location in the reservoir where resistance to the fluid movement becomes greater than the forces causing this movement. What is an oil (and/or gas) accumulation? The "Petroleum Reference Book" (1984, p. 205–206) gives the following definition: "All writers define an oil and gas accumulation as a single aggregation of these mineral resources. Sometimes such accumulation is called elementary, local, isolated, or restricted from all sides... The major accumulation parameters are the quality and amount of oil, gas and condensate. The shape and habitat of an accumulation are determined by the type of reservoir and trap, temperature, pressure and natural drive (energy)". What is not clear in this definition is the expression "single aggregation" and the ensuing idea of the outline (contours) of the accumulation.

It is well established that all hydrocarbon accumulations contain some water, the content of which may be 2% or "greater". What does "greater" mean? When evaluating the hydrocarbon reserves, it is common to determine the oil–water contact from the depth of perforations that produce a water-free oil, or (in the case of log determinations) of the calculated oil saturation in excess of 50%. This is actually quite definite. All oil accumulations contain at least 0.2–0.5% of water, which is in no way a reflection of its true content, due to the relative permeability. Even a reservoir with the oil saturation below 50% can yield the water-free oil (depending on the fluid properties). The definition "log-calculated saturation of 50%" is also not clear. A flow of water-free oil as well as the flow of water alone can be obtained from such a reservoir.

The issue of the contacts and fluid separations (w-o-g) in the reservoirs requires further studies. It is especially important in the case of presence of emulsions in the accumulations. This is observed in many small and medium size accumulations in the Western Siberia and in the Eastern Pre-Caucasus (Sudarikov, 1978). How does one interpret the concepts of "oil–water contact" and the fluid (w-o-g) "separation" surfaces, which are crucial in the appraisal, development and reserve calculation? Is it possible that by changing the production technology we will be able to recover commercial hydrocarbons outside the "contours"?

A special category among the accumulations, the conditions of which deviate from the average, are hydrocarbon accumulations at "great" depths with temperatures above 120–150°C. Changes in the physical conditions at great depths create a totally different environment.

Attempts to determine the speed of migration in the process of oil and gas accumulation, assuming a uniform filling, were not successful. For example, during the formation of the Anastasyev-Troitsk Field (North Caucasus) the length of migration was 25 km, and the life of the structure was 15 MMY. Thus, the speed of migration was 1.7 mm/year (Maksimov et al., 1977).

Based on all the aforementioned, it can be stated that the fluids move non-uniformly, and their speed may reach up to tens and even hundreds of meters per year (established for water). According to Beletskaya (1990, p. 281), the most intensive

hydrocarbon expulsion stage coincides in time with the maximum generation. The following question arises here: When was it happening?

9.4. TIME OF FORMATION OF HYDROCARBON ACCUMULATIONS

There are many methods of determining the time of formation of hydrocarbon accumulation (Mikhaylov, 1984):

9.4.1. Paleogeologic Method

The paleogeologic techniques enable the scientists to determine the time when an accumulation began to form. Two seemingly clear-cut premises are valid here: (1) the accumulations could not form prior to the rocks in which the accumulation is located and (2) the accumulations began forming only after the formation of trap.

The latter premise, apparently clear, turns out to be indistinct when the time of trap formation is determined. The most common way of determining the time of formation of structures is based on the environment of lithofacies formation, as proposed by Belousov in 1942. Unfortunately, the restrictions of the paleotectonic technique proposed by Belousov (1942) are usually neglected. They include, in particular, the limitations of the lateral size and the nature of facies. As a result, the paleotectonic analysis of the formation of structures is reduced to the comparison of thicknesses, which does not reflect either the timing or conditions of the structure formation. As a consequence, different geologists arrive at quite different conclusions regarding the same region.

The time of formation of a fault trap is bracketed by the time of the fault formation. The formation time of a stratigraphic trap is determined by the age of immediately overlying sediments.

An accumulation is formed as a result of migration of hydrocarbons. Migration by buoyant force can begin only if there is a regional tilt. The steeper the slope, the stronger the buoyant force. Could this be the reason for an early formation of oil accumulations over the geosynclinal flank of the foredeeps?

9.4.2. Mineralogic Technique

The essence of the mineralogic technique is determining the sequence of post-depositional alterations within the oil-saturated reservoir and within the same reservoir outside the OWC. Liquid hydrocarbons cause retardation of catagenic processes within the accumulation of hydrocarbons, compared with those outside of it.

Important in the application of this technique is to determine the morphologic relations between the oil and authigenic minerals, as well as to find oil in the voids having resulted from the dissolution of carbonates and sulfates at various stages of catagenesis. The position of an old oil–water contact may be identified from the mineralogical data (Sakhibgareyev, 1985), in order to determine the history of accumulation.

A negative aspect of this technique is usually obtaining overblown results due to the incomplete conservation of the catagenetic processes in the presence of liquid hydrocarbons.

9.4.3. Helium–Argon Technique

The helium–argon technique was developed by Savchenko in 1935 and published in 1977. The technique is based on the ratio of the radioactive helium and argon of cosmic origin of gases dissolved in water: $t = 77.1 \text{ He/Ar} \times 10^6$, where t is the time the water resides in rocks and He/Ar is the ratio of their contents in water in %, by vol. The technique was improved in 1950 by Kozlov (taking the solubility into account) and in 1955 by Cherepennikov (in: Eremenko and Chilingar, 1996) (introduction of correction coefficients). Critical analysis by V. P. Yakutsina and V. V. Tikhomirov (in: Eremenko and Chilingar, 1996) showed that helium and argon in gases and water have several origins. Besides, the error in determining the He/Ar ratio can exceed 60%.

9.4.4. Determination Based on the Composition of Oil Fractions with Boiling Point Below 200°C

The technique based on the composition of oil fractions with boiling point below 200°C was introduced by A. N. Reznikov (1967, in: Eremenko and Chilingar, 1996) and is based on the catagenetic transformation of oil:

$$C_{\text{oil}} = fAP^3/N^4 \quad (9.3)$$

where C_{oil} is the degree of catagenic transformation of oil; A, P, and N are the contents of aromatic, paraffinic, and naphthenic hydrocarbons (in %). C_{oil} ranges from fractions of 1% in the Cenozoic oils to a few dozens of percent in the oils from Paleozoic deposits.

The age of oil as determined by this technique reflects the time duration that the oil resided within an environment at certain temperature interval. The effects on the results obtained by the source organic matter and its catagenetic alteration, as well as the effects of weathering on the generated oil, are unknown.

A number of techniques (mostly physical) were developed to help determine the time of formation of oil and gas accumulations.

9.4.5. Volumetric Technique

The volumetric technique is based on the Boyle-Marriotte and Clapeyron equations and has been proposed by A. Levorsen in 1958. Inasmuch as the reservoir pressure by the end of formation of accumulation is assumed to be hydrostatic,

$$H_f/g = (P_0V_0/P_fV_f)(T_fZ_f/T_0Z_0) \quad (9.4)$$

where H_f is the thickness of overburden, P_f and P_0 are the reservoir pressures at the time of formation of accumulation and at present, T_f and T_0 are the temperatures at

the time of formation of accumulation and at present, and Z_f and Z_0 are the gas compressibilities at the time of formation of accumulation and at present.

The calculation is conducted in two stages. At the first stage, the ratio $T_f Z_f / T_0 Z_0$ is assumed to be equal to 1 due to the unknown value of the numerator. The time of formation of accumulation is determined from the stratigraphic section at depth H_f . At the second stage, a more accurate H_f value is determined taking into account the T_f and Z_f values as determined from the previous H_f calculation.

This method was refined by K. M. Marchenko, V. A. Kirov, V. A. Chakhmakhchev, etc. (in: Eremenko and Chilingar, 1996), but the imprecision due to the “trial and error” approach has not been eliminated. Most acceptable results were obtained when determining the accumulation age in several closely positioned accumulations within the same productive formation (especially, if they had been formed according to the differential entrapment principle).

9.4.6. Saturation Pressure Technique

The gas-saturation pressure method has been proposed by Gussow in 1953. The assumption is that the gas-saturation pressure at the time of formation of accumulation has been hydrostatic. With increasing overburden pressure, the reservoir pressure increased, whereas the saturation pressure remained the same. The time of formation of accumulation is determined using the depth of reservoir, where the reservoir pressure is equal to the saturation pressure. The determinations are usually made using cross-sections.

A drawback of this technique is the assumption of equality between the saturation and reservoir pressures at the time of formation of accumulation. As previously mentioned, at least 40% of the liquid hydrocarbons formed are initially undersaturated.

The accumulations begin to be destroyed at the moment they begin to form. Their very existence is a temporary phenomenon related to the dominance of accumulation processes over those of destruction. Gas diffusion is associated with all gas accumulations. The calculations by V. A. Sokolov and V. F. Linetsky (personal communication, 1994) showed that any commercial gas accumulation (at a depth of 1,000 m and initial pressure of 10 MPa) would be destroyed through diffusion of gas within a few million years. Apparently, gas accumulations are preserved due to their replenishment. The effect of gas diffusion is much weaker in oil accumulations, but still may cause substantial alterations in oil composition.

Eruptions cause significant destruction of oil and gas accumulations. This is evidenced by the mud volcanoes (Buryakovsky, 1993; Buryakovsky et al., 2001) and other massive oil and gas seeps associated with faults (Khilyuk et al., 2000). As shown in Chapter 3, the fault zones are often less permeable than the adjacent reservoirs. A fault may act as a seal in one location and may be highly permeable in another location along its length. Also, permeability of fault zone can change with time depending on the geologic conditions (including thermodynamic and geochemical). Finally, the oil composition can change within the weathering zone or the accumulation can be totally destroyed by erosion.

This page intentionally left blank

Chapter 10

CLASSIFICATIONS OF OIL AND GAS ACCUMULATIONS

10.1. CLASSIFICATION OF TYPES OF OIL AND GAS ACCUMULATIONS AND TRAPS, RESERVES, FLUID QUALITY, PRODUCTION RATES

Oil and gas fill the pores, vugs, and fractures in reservoir rocks. Usually, not the entire reservoir but only its part called “trap” is filled with petroleum. There are numerous classifications of traps depending on their relationships with the reservoir, lithology, rock origin, tectonics, trap size and shape, and the type of energy distribution. Criterion of usefulness of a classification or a definition is its applicability. Particular purpose, limited in scope, gives rise to incomplete classifications. The development of a natural classification for the traps and/or reservoirs is very difficult, first of all, due to the lack of knowledge about the formation of hydrocarbon accumulations at high pressures and temperatures.

The most definitions of a trap include the following concepts:

- trap is a part of the reservoir where oil and gas can accumulate (Levorsen, 1954),
- where relative equilibrium of movable components is maintained by the gravity (Brod and Eremenko, 1950),
- where the potential of oil and gas locally reaches a minimum, and
- which is limited by a closed equipotential surface.

With increasing temperature and pressure, the effect of gravity on the fluid distribution decreases.

The existing trap classifications can be divided into three groups.

The *first* and the most common classification group is called the “Oil and gas classifications” by many authors. Yet, these authors do not stress the parameters (characteristics) of the accumulations, but instead of the crustal elements in which they are housed, i.e., traps (their genesis, structure, shape, and type of reservoir).

The *second* classification group associate the trap shape with the conditions of its formation: folds, faults, stratigraphic unconformities, lithological barriers, and combinations of the above.

Finally, the *third* group of classifications stressed the hydrodynamic head.

In every case, the trap is considered to be a part of the reservoir, with substantial emphasis on its geometry, which is undoubtedly important when selecting locations for exploratory wells.

The accumulation represents a temporary accumulative stage against the background of migration, and the trap forms such part of the Earth’s crust (reservoir), where this accumulative stage may occur under certain geologic environments (including the thermobaric and thermodynamic conditions).

Not considering the genetic issues, the trap should be characterized by the

- type of the reservoir it is associated with (including the lithology),

- shape, lateral extent, and height in relation with the positions of possible hydrocarbon cross-flows, and
- type of the barrier restricting the migration, which at the same time defines the accumulation boundaries.

Any trap classification reflecting these conditions can be considered practical.

The accumulation of hydrocarbons, filling the trap, is an elementary accumulation of hydrocarbons, the major parameters of which are their quality and quantity and the accumulated energy. Besides, additional parameters must provide necessary information for a successful appraisal and subsequent development of the accumulation. Such parameters include the degree to which the traps are filled and the nature of the gas–oil–water contacts. The former depends on the environment of trap formation and the tectonic evolution of the basin. In many cases, certain patterns in the degree to which the traps are filled can be identified in a basin for a particular stratigraphic interval. This may be successfully used in exploration and estimation of resources of a particular stratigraphic sequence.

The locations of the gas–oil–water contacts are important during the exploration and development phases. The knowledge of the tilt of oil–water contact, if present, may prevent drilling of unnecessary wells. The task gets more complicated if there are no definite contacts, replaced by transitional zones. Besides, the contour must be closed (also against a barrier).

If the amount of hydrocarbons in an accumulation is sufficient to conduct production, the accumulation is called commercial. This concept is uncertain and depends on many factors, such as the geographic location, available infrastructure, depth, quality of hydrocarbons, and the presence of beneficial or harmful admixtures.

Most common classifications of the size of oil and gas accumulations in the US and Russia are presented in Table 10.1. This table shows that in the US greater effort is devoted to the development of small accumulations than in Russia. The reasons for that include the following:

1. A more advanced oil and gas-producing equipment in the US enables to produce economically from the smaller accumulations.
2. Smaller accumulations are neglected in Russia, and only larger accumulations are developed because of economics and lower demand of oil than in US.

The classification of the accumulations by the average rate of production is also quantitative. Kontorovich et al. (1975), for example, proposed the classification presented in Table 10.2.

The class boundaries are tentative and may be changed to fit a specific situation for a particular petroliferous province. It is important to keep in mind the fact that the flow rates reflect not only the natural conditions of the accumulation (lithology, fluid properties, energy of accumulation, etc.), but also the technology (development techniques, well facilities, etc.). Besides, the boundary between the low-rate and non-commercial classes is determined by the economical–technical reasons. The price of the oil and gas determines the position of such boundary, and the political situation (e.g., embargo) may impose the development of even very small accumulations.

TABLE 10.1

Classifications of oil and gas accumulations on the basis of size

Accumulation category	Oil reserves (MMT ^a)	Gas reserves (BCM ^b)
<i>United States</i>		
A	> 6.85	> 8.5
B	3.42–6.85	4.2–8.5
C	1.37–3.42	1.7–4.2
D	0.14–1.37	0.2–1.7
E	< 0.14	< 0.2
F	Non-commercial	
<i>Russia</i>		
Unique	> 300	> 500
Large	300–30	500–30
Medium	30–10	30–10
Small	< 10	< 10

^aMMT = million tons.^bBCM = billion cubic meters.

TABLE 10.2

Classification of oil and gas accumulations on the basis of production rate

Class	Accumulation category	Production rate	
		Oil (TD ^a)	Gas (CMD ^b)
1	High rate	> 100	> 1,000,000
2	Medium rate	10–100	100,000–1,000,000
3	Low rate	2–10	20,000 – 100,000
4	Non-commercial	< 2	< 20,000

^aTD = tons/day.^bCMD = m³/day.

10.2. CLASSIFICATION OF HYDROCARBON ACCUMULATIONS BASED ON PHASE RELATIONSHIPS

An important factor in the qualitative characterization of an accumulation is the phase relationships of the fluids present. This is more complicated, however, than just the identification of liquid (oil) and gaseous (gas) phases.

10.2.1. Gas accumulations

Free gas accumulations containing only C₁–C₄ hydrocarbons are rare and encountered at shallow depths. As mentioned in Chapter 6, as the temperature and

pressure increase, the retrograde phenomena cause dissolution in the gas of heavier hydrocarbons (up to C_{15}). Such accumulations become gas-condensate accumulations. The assignment of an accumulation to the free gas (dry) or gas-condensate category is highly important for the production purposes.

In order to prevent the loss of condensate in the reservoir, gas-condensate accumulations must be developed with pressure (desirably also temperature) maintenance. The boundary between the dry gas and gas-condensate accumulation is tentative and is set most often at 20–250 cm³ of condensate per 1 m³ of gas. There is an easy transition from gas to condensate (or vice versa) type of accumulation with changing temperature and pressure. When the price of gas depends on its heating value, a more detailed classification based on the condensate content can be prepared for practical purposes.

The produced gas always contains some water. The water may be the water of condensation (i.e., water dissolved in gas together with the heavier hydrocarbons), and may be carried by the flowing gas. There are numerous sources of the condensation water: (1) the capillary and “submelted” water (see Chapter 4); (2) beyond-the-contour water; (3) bottom water; and (4) water coming from the water-saturated lenses and interbeds within the gas-bearing formations. Even a slight decrease in the pore throats of clastic reservoir rocks may create water blocks. Removal of water blocks may occur as the reservoir conditions change during the development and production.

The water may be retained for a long time within the fine-grained hydrophilic lenses or interbeds; however, the water may begin to enter the flowing gas as the pressure differential between the lenses (interbeds) and producing formation increases. Mathematical models have been developed for calculating such phenomena. As the temperature increases (due to increasing depth of burial or, rarely, due to technological reasons) the interfacial tension decreases, which may result in an increase in production water-cut. Water coning and fingering can occur in the water-drive gas accumulations, i.e., accumulations underlain by water. Certain gas production techniques must be designed to prevent this from occurring.

The nature of gas accumulation's contact with the underlying fluids is of the utmost importance. If the accumulation is totally underlain by water, it is called a single-phase gas accumulation (although two phases, liquid and gas are actually present). At shallow depth with a temperature of 60–80°C and pressure below 10 MPa, the accumulation has a rather clear-cut gas–water contact. When the temperature increases to 120–130°C and if the gas enters the contact zone at a speed greater than that of its dissolution in water, a gas–water emulsion forms (in the transition zone). Sometimes, such a transition zone can constitute the entire accumulation. Although the emulsions have been known for a long time, the emulsion-type accumulations as a separate type was first identified by Kontorovich et al. (1975, pp. 426–427).

As the temperature further increases beyond 120°C and the pressure increases beyond 20 MPa (critical pressure of water = 21.8 MPa), the water solubility in gas drastically increases (retrograde evaporation and a decrease in interfacial tension). These conditions are unfavorable for the preservation of gas–emulsion or gas–water

accumulations (rims). The gas under these conditions, even if not underlain by oil, extracts enough hydrocarbons from the reservoir rocks (primary condensate) to be considered as a gas-condensate. A transition zone between the gas-condensate and the water is a gas–water solution, which is not an emulsion because the droplets and their bounding films are absent. Such a transition zone may constitute the entire accumulation.

Thus, the following transformations of gas accumulations can occur with increasing formation temperature and pressure: gas accumulation → gas-condensate accumulation with an emulsion (gas–water) fringe → emulsion (gas–water) accumulation → gas–water solution.

10.2.2. Oil accumulations

As with gas accumulations, oil occurs always with water. To be accepted for refining or pipeline delivery, the oil should be “water-free,” i.e., water content must be below 2%. The latter is a tentative boundary, which can be changed.

As in the case of gas accumulations, beside a small content of dissolved water, other types of water may be present at moderate temperatures (no higher than 80–100°C) including: (1) capillary water; (2) “submelted” water; (3) water from water-saturated lenses and interbeds within the accumulation; (4) water from water coning and fingering; and (5) the bottom-water or edge-water. Influx of water into the accumulation from the overlying or underlying aquifers due to poor cement job and casing corrosion is not considered here.

At low and moderate temperatures, the oil–water contact is usually clear-cut (distinct).¹⁵ If, however, the temperature is higher than 80°C (sometimes lower, depending on the water and oil composition), an emulsion forms the transition zone. Its thickness can vary and can even comprise the entire accumulation, i.e., a stable emulsion is present throughout the entire accumulation (Kontorovich et al., 1975).

Gas is always present in oil and even after a long period of weathering the oil still contains gas. As an example, some formations of the Productive Series in Azerbaijan (Buryakovsky, 1974; Buryakovsky et al., 2001) are exposed at the surface in the Yasamaly Valley of the Absheron Peninsula. Despite a long (a few tens of thousands of years) erosion, the hydrocarbon gas is continually seeping from these formations together with oil (this prevents an open-pit development).

The pressure under which dissolved gas resides in the oil is of importance. When the pressure is close to the atmospheric pressure, some gas is released at the free surface of oil. This gas is usually non-commercial. Gas-saturated oil remains a single-phase liquid until the saturation pressure (i.e., the pressure of the dissolved gas) reaches the reservoir pressure, after which a gas cap can form.

¹⁵If anaerobic bacteria are present, they may destroy the oil–water contact and form a peculiar transition zone. In such a case, a clear oil–water contact disappears.

Gas in a gas cap can behave differently (see Chapter 6):

- (1) At low and moderate pressure, the gas solubility in oil is governed by the Henry's law.¹⁶
- (2) At higher temperature and pressure (60–80°C and 8–10 MPa), retrograde phenomena begin to occur, and the gas in a gas cap is converted into the gas-condensate state. As mentioned in Chapter 6, the boundary beyond which the retrograde phenomena occur is determined not just by the temperature and pressure, but also by the chemical composition of oil and gas.

As the basin subsides, the nature of the gas–oil and oil–water contacts changes. Clear (distinct) contacts are replaced by transition zones. The transition zones show the high oil content in gas or water; then, they are replaced with emulsions which, in turn, are replaced by gas–oil solutions involving the entire accumulation.

The issue of the phase state of fluids in the transition zone is still somewhat open. It is possible that the emulsion forms only when the fluids enter the borehole (due to the turbulent flow of fluids when they enter the well). Such accumulations have been called “the transitional stage accumulations” (Vasilyev et al., 1966).

A further subsidence (temperature of about 280–350°C) results in the unlimited mutual solubility of hydrocarbons and water. The upper gas–oil (or vapor–oil) transitional zone merges with the lower, water–oil transitional zone, forming a single accumulation.

The unlimited mutual solubility is an indication that the fluids are in the supercritical state or close to it. A drastic increase in the mutual solubility of the fluids that have been insoluble in each other before occurs on approaching the critical point. This is observed in chemically different oils and water even at 120–150°C and becomes pronounced at 180°C.

Oil accumulations that are undersaturated with gas may approach (through the vapor phase) the described accumulation type. Apparently, they should be called “the critical-state accumulations”. The liquid phase and vapor phase merge at the critical point so that one phase cannot be distinguished from the other. Also, interfacial tension disappears, diffusion stops, density and composition fluctuations appear, relative permeabilities significantly decrease (there are no phases, just molecules of different sizes and composition), etc.

The boundaries of such a system are determined only by the available space, by the thermodynamic conditions, and by the direction of migration (the availability of migration avenues and by the system's energy).

Inasmuch as the critical-state fluid system is characterized by the absence of distinct phases and of the gravity separation, the major premises of the gravity hypothesis of the formation of hydrocarbon accumulations and its practical applications are negated. The hydrocarbons may not move updip, toward the anticlinal crests. The absence of phases and of interfacial tension makes the concept of the hydrodynamic trapping unrealistic. The absence of capillary pressure converts some seals into reservoirs.

¹⁶According to the Henry's law, the amount of a gas absorbed by a given volume of liquid at a given temperature is directly proportional to the pressure of gas. This law, which was first formulated in 1803 by the English physician and chemist William Henry, holds only for dilute solutions and low gas pressures.

The above discussion may explain the unsuccessful oil and gas exploration efforts at great depths in many cases. Usually, the wells have been drilled over the crests of the structures that may not be the best location for finding “critical-state” accumulations, in the absence of fluid gravity separation. Most often, the well tests have been conducted in sandstones. Yet, the reservoir rocks of the “critical-state” accumulations may be argillaceous rocks, whereas the sandstones may have acted as seals. Large pressure drawdown had been usually applied to cause the flow of fluids, which may have closed the flow channels (pore throats and canals) around the borehole due to the overburden pressure. In the case of fluid flow, an attempt is made to maintain the pressure (which was already much higher than critical), whereas the temperature should have been maintained.

The above discussion may explain the well test results in superdeep wells (around 30,000 ft or 10,000 m), i.e., mostly weak flows of gas-cut water (sometimes oil-cut) have been obtained. Inasmuch as the temperature and pressure change near the boreholes, the flow conditions change (fractures close) and different phases separate out. Thus, the main exploration tools are based on the state of system and its energy, and the measurements of density, electric conductivity, seismic velocity, etc., may become very important. A further subsidence of the accumulation, at very high temperatures and pressures will result in the total decomposition of the system. It is difficult to estimate the temperature at which this may occur; it may reach more than 1000°C at pressures of hundreds of MPa's.

As far as the classification of oil accumulations based on the phase transformations are concerned, two branches are present that merge in the “critical-state” accumulations.

Fig. 10.1 shows phase transformation at a relatively mild (Fig. 10.1a) and harsh (Fig. 10.1b) conditions of temperature and pressure. The presence of a clear-cut contact between the oil and gas is indicated by the K1-K2 line in Fig. 10.1a. On the other hand, Fig. 10.1b shows gas–oil transitional zones (dashed lines) with definite contacts being absent. Transitional zones to water (4, 5 and 6) appear at the base of accumulations. With passage of time and as the environment becomes harsher, first a gas–oil transitional zone (3) and then the oil–water transitional zones appear. This is due to the better mutual solubility of hydrocarbon gases and oil, compared to hydrocarbon gases and water. The appearance of the oil–gas transitional zone is possible at temperatures much below 120°C (i.e., within the limits shown in Fig. 10.1a), depending on the oil and gas composition. Light paraffinic oils (density $< 0.8 \text{ g/cm}^3$) and wet gases can form a transitional gas–oil zone at rather mild temperatures and pressures.

Zone 1a widens substantially due to vapor generation. The very existence of Zone 1 at higher temperature and pressure (Fig. 10.1b, oil without dissolved gas or vapor) is in doubt. Zone 2 (dry gas) disappears and is replaced by the gas-condensate Zone 2a. The condensate content within this zone may vary significantly. If the “donor” oil is absent, the gas will dissolve bitumens from the rocks (“primary condensate”: Starobinets et al., 1986; Chakhmakhchev, 1982). A complex gas–oil–water zone (Zone 6) appears under conditions shown in Fig. 10.1b. As the conditions become even more rigid (more severe), this zone becomes the major one, gradually forming the “critical-state” accumulations.

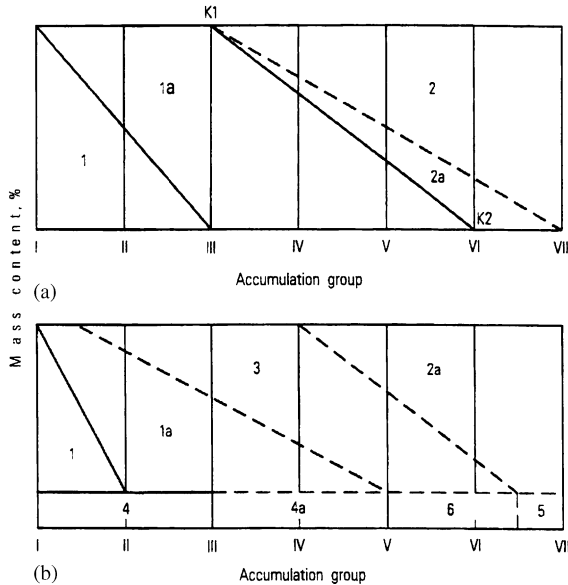

Fig. 10.1. Classification of hydrocarbon accumulations based on phase relationships. I – VII: Accumulations in (a) mild and (b) harsh (very high temperatures and pressures) conditions. I – oil; 1a – oil and solution gas; 2 – gas (dry); 2a – gas and condensate; 3 – gas – oil transitional zone; 4 – oil accumulation without distinct OWC; 4a – oil – water transitional zone; 5 – gas – water transitional zone; 6 – gas – oil – water transitional. (After Eremenko and Chilingar, 1996, p.112.)

If subsidence is replaced by uplift, the reversal of these processes is practically impossible. Most of the processes in the Earth's crust are irreversible, e.g., impossible for a well-compacted fractured reservoir rock to become a sediment if the basin experiences an uplift. Different processes occur during the uplift, which result in the destruction of accumulations. Groups of deposits shown in Fig. 10.1 are also presented in Table 10.3.

Pressure maintenance in the development (production) of accumulations in the case of groups Ia–IVa is not to prevent the possible dropout of condensate. It may be undertaken to accelerate the production schedule and to improve the fluid recovery. Here, additional difficulties arise due to hydrophilic nature of rocks. Pressure maintenance in the groups Va and VIa does help prevent the condensate drop-out.

Pressure maintenance in the case of groups Ib–IIIb is necessary to improve the condensate recovery. It is possible that some pressure decline in the accumulations belonging to type IVb and, perhaps, (IIIb–VIIb) will not result in the loss of condensate. Inasmuch as the reservoir pressure here is usually much higher than critical, the pressure may decline almost to a critical value. This can be determined by laboratory analyses of the samples at reservoir conditions. In order to prevent the breaking up of oil–gas–water mixtures (solutions) near the borehole zone (group IVb or VIIb) not only the pressure but also the temperature must be retained.

The qualitative composition of the oil in accumulations may be described from a prevailing hydrocarbon type (see Chapter 5). The gas condensates can be subdivided

TABLE 10.3

Accumulation groups based on phase relations

Mild environment (a)	Severe environment (b)
I. Oil accumulations with no dissolved gas; oil–water contact is distinct.	I. Oil accumulations with no dissolved gas (possibly nonexistent in this environment).
II. Oil accumulations with dissolved gas ($p_{\text{res}} > p_{\text{satur}}$). Oil–water contact is distinct.	II. Oil accumulations with dissolved gas. Oil–water contact is not distinct.
III. Oil accumulations saturated with gas ($p_{\text{res}} = p_{\text{satur}}$). Oil–water contact is distinct.	III. Oil accumulations saturated with gas ($p_{\text{res}} = p_{\text{satur}}$). Gas–oil transition zone appears in the upper portion. Contact with water is not distinct.
IV. Oil accumulations with gas cap ($p_{\text{res}} = p_{\text{satur}}$). Gas contains some condensate. Oil–water contact is distinct.	IV. Oil accumulations; transition into gas–oil mixture in the upper portion. Oil–water transition zone instead of oil–water contact.
V. Gas accumulation with condensate underlain by oil. Oil–water contact is distinct.	V. Gas accumulation with condensate. There is a transition into oil–gas zone down the section. Oil–water transition zone instead of oil–water contact. Gas–oil–water zone at the base.
VI. Gas accumulation rich in condensate. Gas–water contact is distinct.	VI. Gas accumulation with condensate and with rim of oil–gas mixture.
VII. Gas accumulation.	VII. Gas accumulation. Gas–water mixture constitutes transition to water.

according to the chemical composition of hydrocarbons and quantity of H_2S and, sometimes, mercury (e.g., in Germany). Noteworthy is the high H_2S content in deep accumulations. For example, the H_2S content in gas in the Astrakhan Field of Russia (at a depth of 3000–4000 m) reaches 24%.

Oil and oil-gas accumulations may be subdivided according to the nature of admixtures in the oil, water, and gas. The most important admixture is sulfur and its compounds.

An important parameter in producing oil is its viscosity. One can use the following classification: low-viscosity oil — viscosity < 5 mPa s, medium-viscosity oil — 5–10 mPa s, high-viscosity oil — 10–30 mPa s, and very high-viscosity oil — greater than 30 mPa s.

When discussing the formation of hydrocarbon accumulations, many authors gave preference to gravity forces. It should be remembered, however, that any occurrence of gravity in the Earth's crust is unavoidably accompanied by the elastic phenomena. Inasmuch as a rule, all these forces are active in the reservoir, most common drives are of a mixed nature. But the most important drives are the water drive and the elastic drives of free and solution gas.

Various geochemical and bacteriological processes are most active near the oil–water and gas–water contacts. Sulfate reduction and underground hydrocarbon oxidation is possible there. Although the most obvious hydrocarbon oxidation in oil accumulations occurs near the oil–water contacts, it is possible that the oil biodegrading occurs within the entire accumulation volume (Petrov, 1984).

Often, there is some decrease in the oil and especially gas density in the clastic rocks with increasing clay content. This statement may be erroneous, however, due to the effect of relative permeability when fluids move from the reservoir into the wellbore.

Light and some heavy hydrocarbons dissolve in the reservoir edge water. Depending on the direction of groundwater movement, front and rear effects may occur (see Chapter 4). One has to remember, however, that oil–water and gas–water transition zones may form in a more severe (high temperature and pressure) environment.

The composition of oil and gas may be affected by the presence of faults that may be either fluid conductors or barriers. These properties, however, may change along the fault and in time, i.e., different segments of the same fault may serve as either a seal or a fluid conductor, which may change with time. The faults can give rise to the mixing of fluids from different horizons, the penetration of chemically or bacterially aggressive water into the accumulation, and a partial or complete loss of hydrocarbons. That is why it is difficult to define clear patterns in the hydrocarbon accumulations in relation to faults. Levorsen (1954) noted that the accumulations are most commonly formed at the hanging wall and only occur at the footwall of faults if there is an additional anticlinal deformation there. As far as the reverse faults are concerned, a somewhat uncertain inverse correlation was found to exist, i.e., the accumulations are more frequently found at the footwall.

The time of fault formation may play a crucial role in the formation of hydrocarbon accumulations. It is interesting to note the role of faults formed during catagenesis (epigenesis) (sometimes the faults are of hydraulic origin). In the low-permeability rocks such faults are not necessarily represented by a continuous surface but rather by an intricate network of channels. The latter do not manifest the disruption of rock integrity but rather accommodate the fluid breakthrough through the existing channel. In this connection, Savchenko (1987) proposed two terms: the *breakthrough pressure* and the *pinch-out pressure* (pressure necessary to close the channel).

Based on the experimental data, the hydraulic fracture pressure and, even more so, the breakthrough pressure is always higher than the hydrostatic pressure and lower than the total overburden pressure. On conducting hydraulic fracturing, it is necessary to overcome the effective pressure and the fracturing strength pressure (Young's modulus, which is very low for the rocks). If the rock density is 2.5 g/cm^3 and the water density is 1 g/cm^3 , the hydraulic fracturing pressure will start at about 1.5 times the hydrostatic pressure.

Breakthroughs and pinch-outs are natural valves controlling temperature and pressure in a reservoir. When a fluid breaks through and leaves the reservoir, some heat is removed thereby lowering the temperature. The entrance of the fluid into another reservoir may create the temperature and/or pressure anomaly in that reservoir. This is one of the reasons for the hydrocarbon accumulations to remain within the estimated temperature and pressure range. The existence of reservoirs that are not amenable to the natural hydraulic fracturing or breakthrough is theoretically plausible. Accumulations with pressure equal to or temporarily even exceeding the total overburden pressure (by the amount of tensile strength — Young's modulus) could have formed. This, however, is the domain of volcanology, and such accumulations are yet to be discovered.

Self-regulation of the temperature and pressure in an accumulation is one of its most remarkable features. Similar phenomena occur in the upper portion of the accumulation due to the surplus pressure (overpressure). It is especially true for the gas accumulations. As a rule, some increase in the temperature and the heat flow is recorded in the accumulations. This can be explained by the heat anisotropy of rocks over the anticlines.

10.3. CLASSIFICATION OF OIL AND GAS RESERVOIRS BASED ON DRIVE MECHANISM

The classification of oil and gas reservoirs by producing mechanism¹⁷ is imperative for a careful study of the technology of oil and gas recovery.

The potential energy sources available to move the oil and gas to the wellbore include the following:

- (1) gravitational energy of the oil, acting over the vertical distance of the productive column,
- (2) energy of compression of the free gas in the gas cap or within the oil-producing section,
- (3) energy of compression of the solution gas dissolved in the oil or the water,
- (4) energy of compression of the oil and water in the producing section of the reservoir,
- (5) energy of compression of the waters peripheral to the production zone,
- (6) energy of capillary pressure effects,
- (7) energy of the compression of the rock itself.

All these forces are active during the productive life of a reservoir.

The predominant producing mechanism operating to produce the oil and gas reflects the relative influence each energy source has on reservoir behavior. The major drive mechanisms are (1) solution-gas drive, (2) gas-cap expansion drive, (3) water drive, and (4) gravity drainage. Each drive mechanism when effective in a pool will give rise to a certain characteristic form of reservoir behavior. Although in practice most pools behave in a manner that represents a combination (“mix”) of two or more drive mechanisms, each mechanism will be described in the context of a single-drive pool. The common characteristics of each drive mechanism can be discussed for clastic reservoirs having intergranular porosity and then placed in the context of the observed behavior of carbonate reservoirs with other types of porosity. The interest is centered on the record of performance: variation of oil, gas, and water production rates, gas/oil and water/oil ratios, and reservoir pressure with time. Movement of the water–oil contact and creation or expansion of a free gas cap is also of great importance.

Natural drive mechanisms may be subdivided into the ones caused by the energy intrinsic in the reservoir and by the energy external to the reservoir. The internal energy is supplied by (1) gravity force, (2) pressure of free gas, (3) solution gas, and

¹⁷Originally prepared by H. H. Rieke, R. W. Mannon, G. V. Chilingar, and G. L. Langnes, in: Chilingar, Mannon and Rieke, 1972. Also see Chilingarian et al. (1996, pp. 243–254).

(4) expansion of the compressed oil. The external energy is the pressure and elasticity of the reservoir edge water and the elastic forces of the rocks. Figure 10.1 demonstrates that the role of gravity drives declines from left to right. Outside the limits shown in Fig. 10.1, in the “critical-state” accumulations the role of gravity force is negligible, and the main active force is elasticity. A prolonged existence of the “critical-state” accumulations is possible only in the case of a strong preliminary compression of fluids and rocks with the subsequent natural relaxation of stress in all directions. Most favorable for the occurrence of the “critical-state” accumulations are bedded (block-faulted) reservoirs. Gravity differentiation is more noticeable in high column accumulations and at a relatively mild temperature and pressure. At higher temperature and pressure, the effect of gravity is considerably lower on approaching the “critical-state” accumulations.

10.3.1. Solution gas drive

In solution gas drive, also called depletion drive, dissolved gas drive, or internal gas drive, the major source to produce the oil and gas from a pool comes from the evolution of dissolved gas from the oil with decline in pressure. No initial free gas cap exists, and the free gas phase formed remains within the oil-producing section. The reservoir is sealed off to a large extent from communication with contiguous water zones by faults or permeability pinch-out. As a result, with declining pressure, the water influx into the reservoir is minor.

Typical solution gas-drive performance is shown in Figs. 10.2 and 10.3. Initially, there is no free gas phase and the instantaneous producing gas/oil ratio is equal to the original solution gas/oil ratio. Except in case of undersaturated reservoirs, the

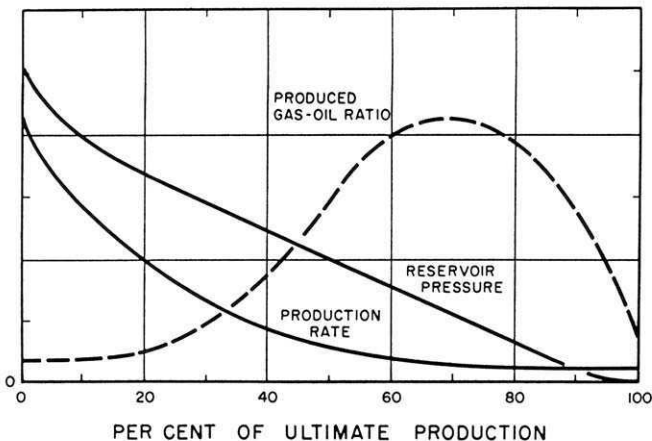

Fig. 10.2. Generalized performance of a solution gas-drive pool (after Torrey, 1961; courtesy of Prentice-Hall, Inc.)

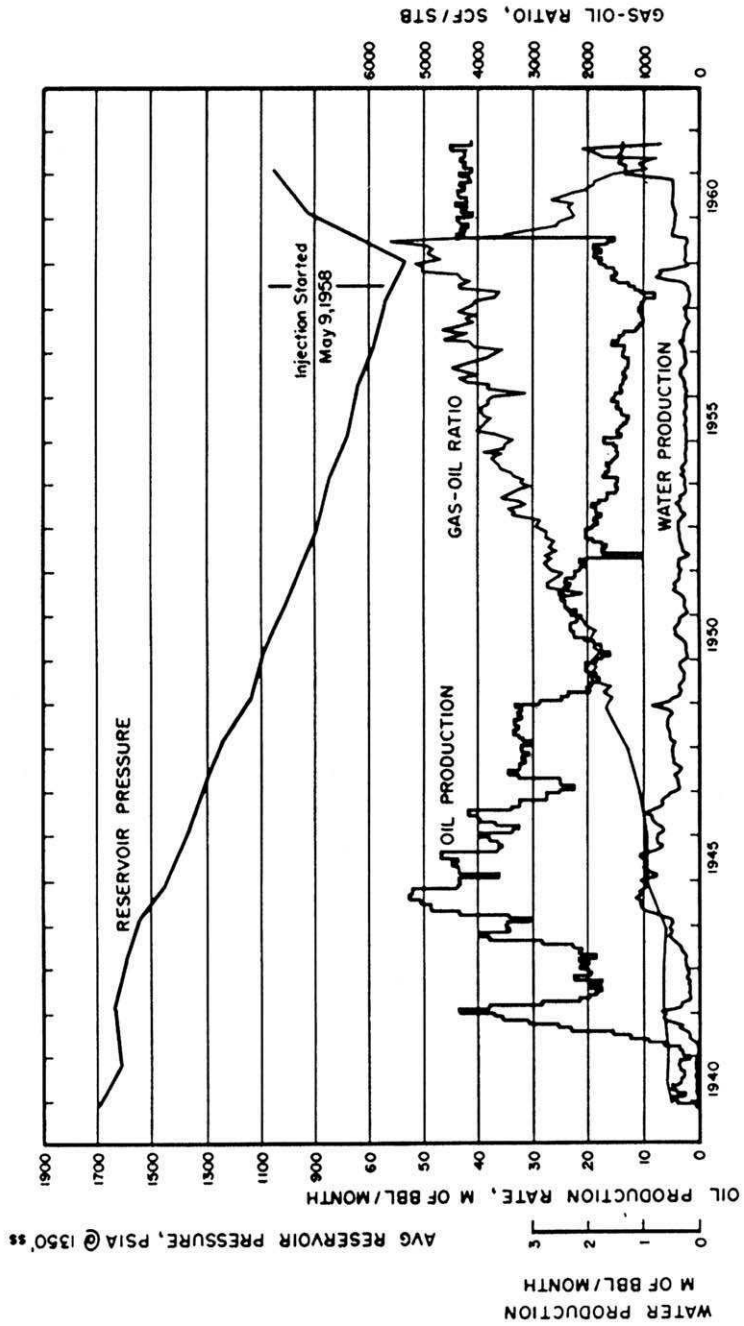

Fig. 10.3. Performance of the Slaughter San Andres Limestone Pool in West Texas, under predominantly solution gas drive (after Sessions, 1963; courtesy of AIME).

finite gas saturation quickly develops and continues to increase as depletion proceeds. At the time the gas saturation reaches the equilibrium value of 5–10%, the gas phase has sufficient mobility and free gas is flowing to the wellbore along with the oil. This results in a rather abrupt increase in the producing gas/oil ratio. The gas/oil ratio continues to rise with increased gas saturation, reflecting the rapid increase in gas flow rate and the attendant decrease in oil production rate. At a gas saturation of 20–30%, the flow of oil becomes negligible, and the gas/oil ratio reaches a peak and then declines as the reservoir reaches the latter stages of depletion.

In undersaturated reservoirs, where the initial reservoir pressure is substantially above the saturation pressure, the production mechanism is oil expansion. Under these conditions, the producing gas/oil ratio will remain at a low level during the time that the reservoir pressure is above the bubble-point pressure. It will approximate the solution gas/oil ratio and ideally should actually decrease slightly as the pressure falls, even though this is rarely observed in the field. The peak gas/oil ratio before it begins to decline, reflecting ultimate reservoir depletion, will normally be 5–10 times as great as the solution gas/oil ratio.

In pure solution gas-drive pools with intergranular porosity, reservoir pressure depends primarily on cumulative oil recovery. Neither reservoir pressure nor ultimate oil recovery is sensitive to oil production rate, unless the production rate affects the producing gas/oil ratio. A rapidly increasing gas/oil ratio, after equilibrium gas saturation is reached, is characteristic of solution gas-drive pools in general. Reducing the production rate will not serve to increase the ultimate oil recovery appreciably. An exception to this rule is found when excessive drawdowns at individual wells lead to excessive transient effects on the reservoir. Any tendency for the reservoir to exhibit significant gravity drainage or water influx, or to form a secondary gas cap, may make ultimate recovery sensitive to production rate.

Solution gas-drive performance is closely related to a number of physical parameters. The ratio of reservoir oil viscosity to reservoir gas viscosity (μ_o/μ_g), solution gas/oil ratio, formation volume factor, interstitial water saturation, and oil and gas permeability relationships largely control performance. The close interrelationship among these parameters is indicated by the fact that a change in one factor results in a change in one or more of the others. Some general and meaningful observations can be made, however, regarding the effect of altering the value of a single factor. As oil viscosity increases, there is corresponding rise in the instantaneous producing gas/oil ratio because of greater gas bypassing, which results in lower solution gas-drive efficiency and lower oil recovery. Also, as the amount of gas available to be in solution decreases, the oil recovery declines. Muskat (1944), however, found that doubling the solution gas/oil ratio resulted in only 10% increase in ultimate recovery. The greater oil shrinkage at higher solution gas/oil ratios serves to dampen somewhat the effect of increased oil solubility on oil recovery, but the shrinkage effect is of only minor importance. An increase in the crude oil gravity ($^{\circ}\text{API}$) as an overall characteristic of the fluid system likewise results in an increase in ultimate recovery. Again the effect is dampened at the higher gravity ranges owing to the greater oil shrinkage, and the ultimate recovery will actually decrease with an increase in oil gravity in the 40–50 $^{\circ}\text{API}$ range.

10.3.2. Gas-cap drive

Oil pools with free gas caps are subject to a gas drive, which is external to the oil zone and separate from the solution gas-drive mechanism. The oil expulsion mechanism is typically a combination of solution gas drive within the oil column plus the added benefit of gas permeating and diffusing into the oil zone from the gas cap. The idealized performance of a gas-cap-drive reservoir is presented in Fig. 10.4. The decline in production rate and reservoir pressure is not as rapid as in solution gas-drive reservoir. The gas/oil ratio performance is more favorable. Gas-cap-drive reservoirs, however, are more sensitive to production rate than are solution gas-drive pools.

Wells producing from intervals close to the gas cap must be produced at low rates to prevent gas coning or recompleated to exclude these upper intervals. The overall gas/oil ratio performance largely reflects such procedures. The performance of the Goldsmith San Andres Dolomite Pool in West Texas (Fig. 10.5) early in its history typifies gas-drive performance with a gradual increase in gas/oil ratio. The oil production is curtailed, and no decline is evident.

Some gravity segregation of oil and gas takes place in virtually every gas-cap-drive reservoir. More pronounced fluid segregation will promote the expansion of the gas cap and downdip movement of the oil, with resultant higher oil recoveries. The size of the gas cap will also affect the oil recovery. Normally, the thicker the gas cap, the greater is the ultimate recovery. Notable exceptions are carbonate pools in the Acheson–Homeglen–Rimbey reef trend, Alberta, Canada, which have large gas caps underlain by thin oil bands. The estimated ultimate oil recoveries under primary production are often very low (5–10%) owing to excessive gas and water coning

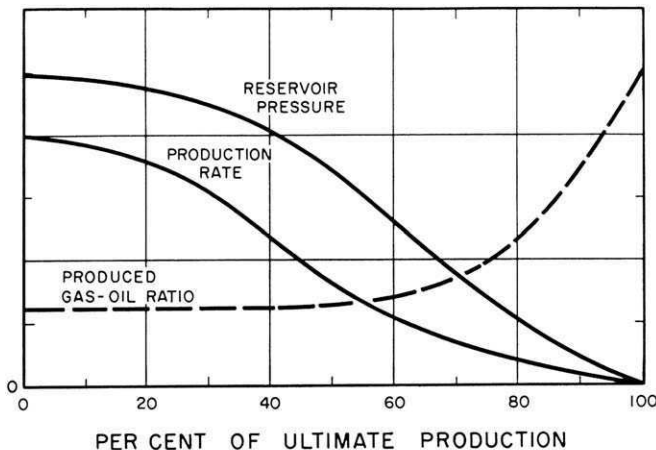

Fig. 10.4. Idealized performance of a gas-cap-drive reservoir (after Torrey, 1961; courtesy of Prentice-Hall, Inc.)

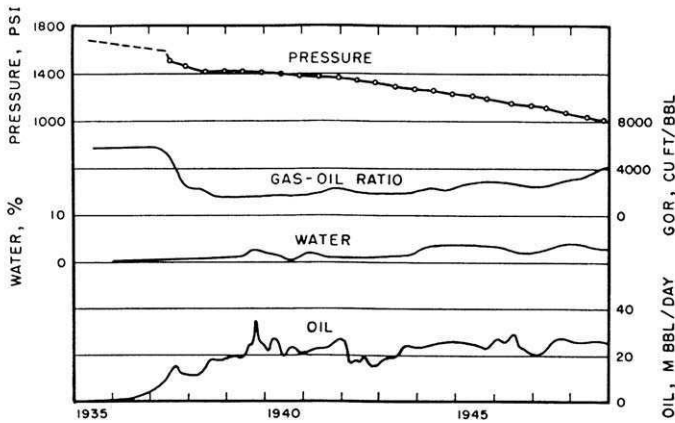

Fig. 10.5. Typical gas-cap-drive performance, Goldsmith San Andres Dolomite Pool in West Texas (after Craze, 1950; courtesy of AIME).

problems. A comparison of the performance of these pools indicates that in the case of thicker oil bands and correspondingly thinner gas caps the oil recoveries are higher.

10.3.3. Water drive

A reservoir of high permeability, such as the fissured or cavernous limestone, in contact with an aquifer of broad areal extent will normally have an active water drive. The degree to which the reservoir withdrawals are replaced by water determines the efficiency of the water-drive mechanism. In complete water-drive systems, which are not common, substantially all the fluid withdrawals are replaced by intruding water. Some excellent examples of complete water-drive pools in carbonate rocks are the Arbuckle Limestone fields in Arkansas and Kansas.

If the reservoir is initially undersaturated, the natural maintenance of the pressure by water influx may result in oil production above the bubble-point pressure for an extended period. During this time a small portion of the reservoir voidage resulting from production (withdrawals) is replaced by expanding oil. Later in the life of the reservoir a free gas phase may form, which provide part of the energy for the oil expulsion. The existence of the free gas will depend largely on the rate of withdrawal of fluids.

In all types of water-drive reservoirs, including complete water-drive systems, an initial pressure decline provides the necessary pressure differential at the reservoir boundary to include water movement into the reservoir. This initial rapid decline preceding water influx is illustrated in general by Fig. 10.6. The Schuler (Reynolds), Magnolia, Buckner, and Midway fields are Smackover Limestone pools, and the

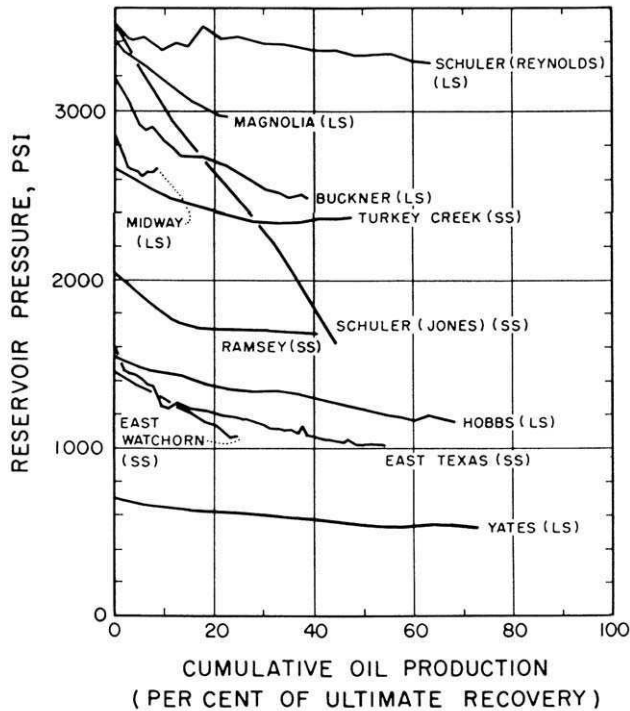

Fig. 10.6. Pressure-production performance of some water-drive pools (after Elliott, 1946; courtesy of AIME).

Hobbs and Yates pools produce from the Permian limestone. The remaining pools are sandstone reservoirs. All of the pools, except the solution gas-drive Schuler Jones Sand Pool, which is included for comparison purposes, are subject to at least substantial, if not complete, water drive (Elliott, 1946).

To summarize water-drive performance, the producing zone first of all is in contact with broad aquifer, normally of high permeability. Decrease in production capacity is minor until water begins to be produced. The produced gas/oil ratio is substantially constant. Figures 10.7 and 10.8 illustrate this type of performance. Recovery factor depends on reservoir-rock characteristics such as pore size and fracture distribution, values for mobility ratio ($k_w\mu_o/k_o\mu_w$), and pool geometry. The rate at which the pool is produced may also affect recovery, particularly if the pool is subject to only partial water drive. Reservoir withdrawal rates greatly in excess of the rate of water influx can lead to performance similar to that of solution gas-drive pools. Free gas saturation in the reservoir can develop in the more permeable section to the extent that incoming water will bypass tighter sections to move preferentially into areas of high gas saturation, with a resulting loss in recovery.

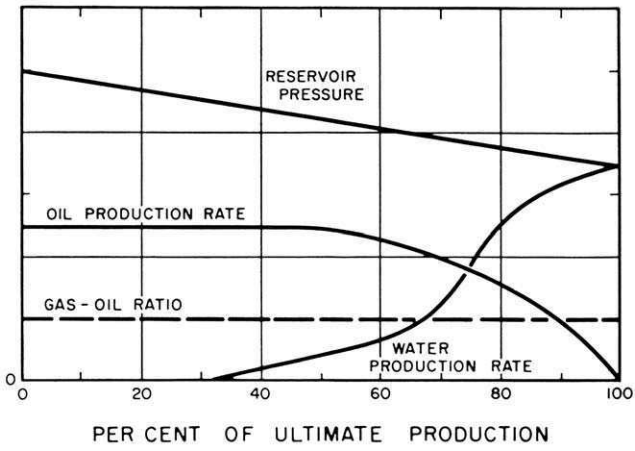

Fig. 10.7. Idealized water-drive performance (after Torrey, 1961; courtesy of Prentice-Hall, Inc.)

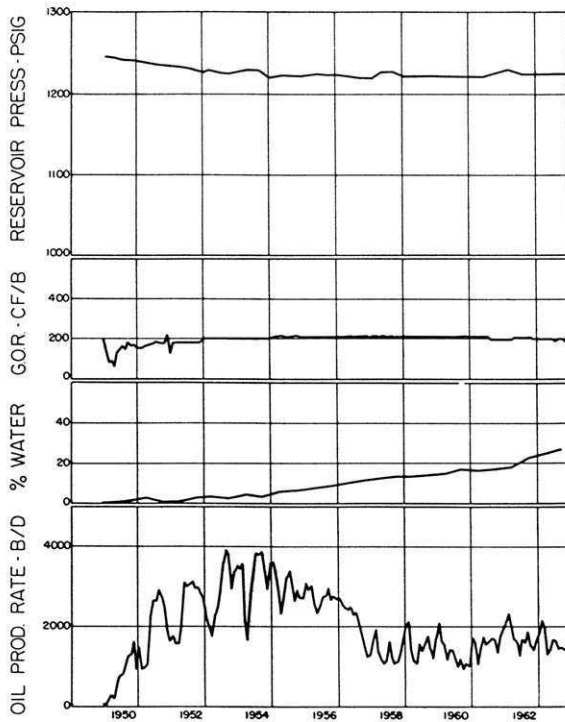

Fig. 10.8. Performance of a water-drive pool, Excelsior D-2 reef pool. Excelsior Field, Alberta, Canada. (Date from Alberta Oil and Gas Conservation Commission.)

10.3.4. Gravity drainage

In oil pool subject to gravity drainage, the gravity segregation of fluids during the primary production process is clearly evident in the production history. Oil migrates down-dip to maintain down-structure oil saturation at a high level, and free gas accumulates high in the structure. If a primary gas cap exists, it will expand as a result of the segregation process. A pool without a primary gas cap will soon form a secondary gas cap. Early in the life of the pool, the gas/oil ratios of the structurally high wells will increase rapidly. A program of shutting-in wells with high gas/oil ratios and of overall discreet control of individual well rates will provide for maximum benefit from gravitational fluid movement. Fig. 10.9 indicates the two cases of the generalized performance of a gravity-drainage pool without (Fig. 10.9A) and with (Fig. 10.9B) such control. The oil gravity, permeability of the zone, and formation dip dictate the magnitude of the gravity drainage. The combination of low viscosity and low specific gravity (high API gravity), along with the high zone permeability and steeply dipping beds, accentuates the down-structure oil movement. Typically, in gravity-drainage pools the water influx is minor and the down-dip wells produce at the lowest gas/oil ratios and have the highest oil recovery. In cases of strict gravity drainage, a major portion of the recovery occurs after complete pressure depletion, when gravity is the primary dynamic force moving the oil to the wellbore.

10.3.5. Combination-drive reservoirs

Some reservoirs may produce under the influence of one or more of the drives discussed above. Throughout the life of a pool a sequence such as solution-gas drive-gravity drainage-water drive may develop, or two different drives may be competing simultaneously (e.g., water-drive reservoir with a primary gas cap). Combination-drive reservoir may be further classified as open or closed, as proposed by Babson (1965).

10.3.6. Open combination-drive reservoirs

The performance of open combination-drive reservoirs is affected by the method of operation and by individual well and pool rates. This type of reservoir is in open communication with the aquifer. Sources of energy include water drive, gravity drainage, and gas expansion. In uncontrolled operations, a gas-expansion stage may occur first, accompanied by a rising gas/oil ratio and declining pressure. A gravity-drainage stage may come next at a reduced reservoir pressure. The effect of a moderate water influx will frequently be evident in the latter stages of the life of the pool. Curtailing production rate will cause a buildup in reservoir pressure as water influx exceeds fluid withdrawals. The performance of the D-3 Pool, Redwater Field in Alberta, Canada, which is a typical open combination-drive pool, demonstrates this effect in Fig. 10.10.

In order to facilitate gravity drainage, the rate of water influx into the reservoir can be reduced by maintaining high water-withdrawal rates from the high-water/oil-ratio

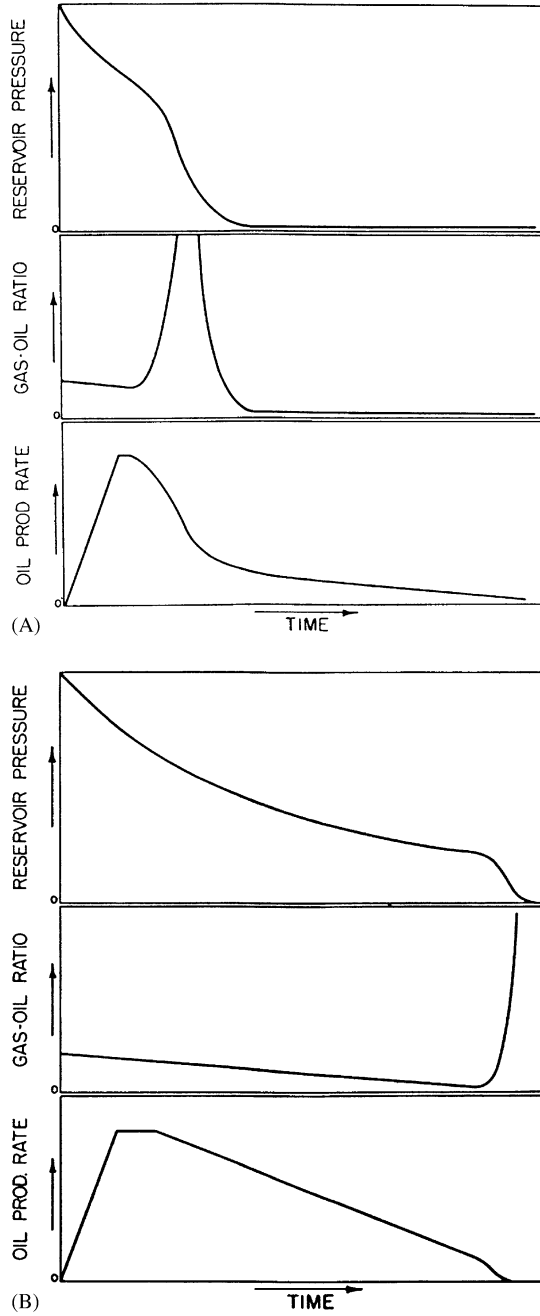

Fig. 10.9. Generalized performance of a gravity-drainage pool produced (A) without control and (B) under control by shutting in high-gas/oil-ratio wells. (Courtesy of E.C. Babson.)

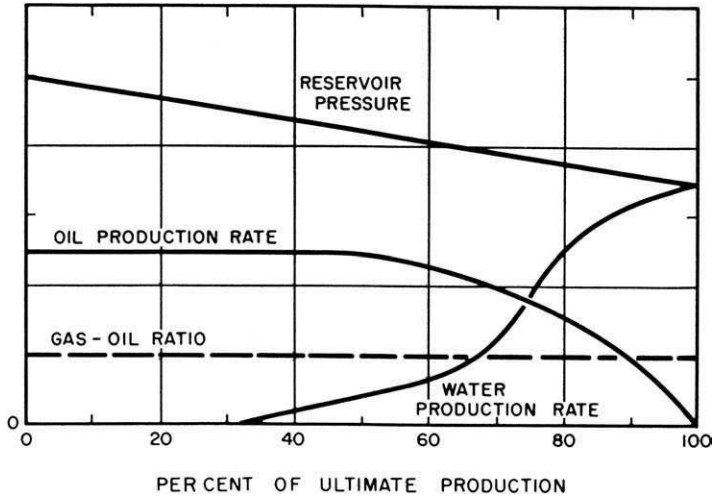

Fig. 10.10. Performance of an open combination-drive pool, Redwater D-3 reef pool, Redwater Field, Alberta, Canada. (Data from Alberta Oil and Gas Conservation Commission.).

wells close to the watertable and controlling the rates of the wells situated higher on the structure. On the other hand, to take full advantage of the water influx, wells producing at high water cuts should be shut in and rates on other wells carefully regulated to reduce problems of non-uniform water influx and water coning.

The combined effect of water drive and an expanding gas cap serve as a very effective oil displacement mechanism. For example, the Leduc D-3 Pool was under both water and gas-cap injection, and flushing efficiencies in the gas cap and water zone were about 80%.

When a pool with an initial free gas cap is subject to an active water drive, steps must be taken to prevent oil movement into the primary gas cap. Oil encroaching into the gas cap, even though subsequently displaced, will leave the residual oil saturation, causing a substantial loss in ultimate recovery. Bruce (1944) cited the case of the Mount Holly Pool in Arkansas, producing from the Smackover Oolite Limestone. An oil recovery was $\approx 35\%$ because of oil lost in the shrinking primary gas cap. The recovery rate of the other Smackover pools in the area should be at least 60%.

10.3.7. Closed combination-drive reservoirs

There is no significant water encroachment in closed combination-drive reservoirs owing to the faulting and/or facies changes so common in carbonate rocks. A gas-expansion stage is usually followed by gravity drainage. Reservoir pressure is low, gas/oil ratios are falling, and updip wells produce very little fluid of any kind during the secondary stage. The role that gravity drainage plays depends, of course, on the net effect of the dip and permeability of the zone and the oil gravity, in addition to the individual well rates. The control of production rates to allow for effective

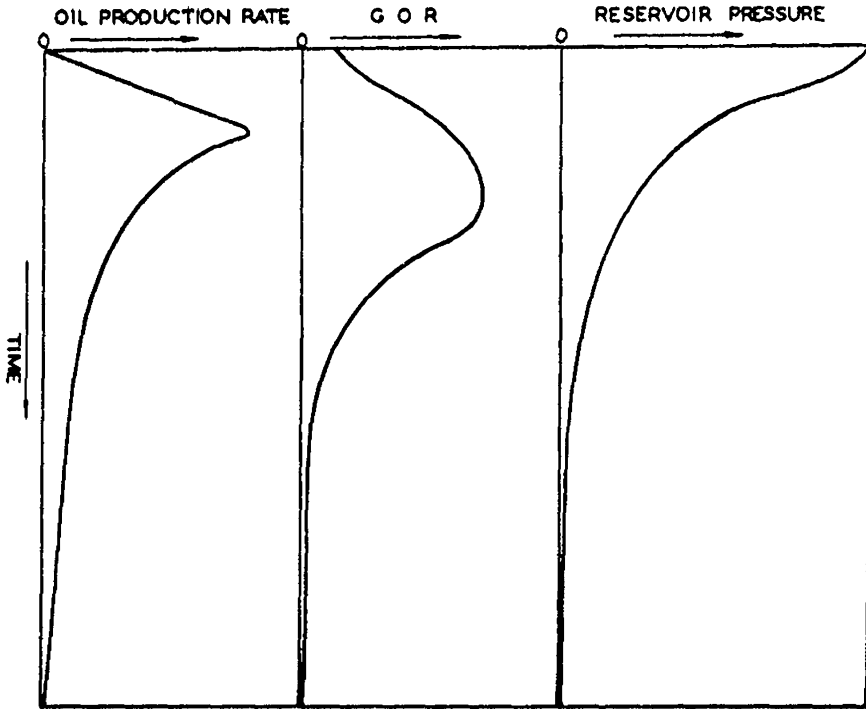

Fig. 10.11. Generalized performance of a closed combination-drive pool produced without control. (Courtesy of E.C. Babson.)

gravity drainage is normally more critical than in the case of strict gravity-drainage reservoirs because of a reduced tendency for downward oil migration. The generalized performance of a closed combination-drive pool produced without control is presented in Fig. 10.11. A good example of this type of reservoir is the Golden Spike Field in Alberta, Canada.

10.4. CLASSIFICATION OF HYDROCARBON ACCUMULATIONS BASED ON THE TYPES OF TRAPS

Although the classifications based on the form, type and genesis of oil and gas accumulations are called the “hydrocarbon accumulation classifications” they are in effect the trap classifications. These trap classifications may be grouped into three major types and four subtypes.

- I. *Traps formed by folding (with or without faults)*. Accumulations formed as a result of folding are usually associated with the bedded reservoirs. The complexity of structure (sometimes even isometric), size, and especially height are caused by the trap and reservoir position in the sedimentary basin. Over the

central areas of tectonic plates, the traps are gentle and sometimes very large. Over the plate margins, transition zones and, especially, collision zones the folds are higher, steeper and with a clearly expressed trend. The accumulations may be classified using some other parameters (mentioned earlier), too. In particular, oil–water contours in such accumulations are closed and, in plan view, have oval or more intricate shapes, and form rings.

- II. *Traps formed within various buildups.* Accumulations formed within various buildups are usually associated with the massive-type reservoirs. Most common are accumulations in biogenic buildups (reefs and bioherms). Sometimes, biostromes are mistakenly attributed to the same class. Included here are large accumulations with huge flow rates due to the presence of fractures and vugs in carbonates. Some investigators also include in this group the erosional projections of the metamorphic and volcanic rocks (fault-bounded or bounded by erosional surfaces), which may contain accumulations, e.g., White Tiger Field in Vietnam.
- III. *Traps that are limited by the depositionally imposed facies changes.* Lithologic and stratigraphic traps of Group III include facies pinch-outs, stratigraphic unconformities, and contact of the reservoir with the impermeable rock upsection. Such traps may be associated with the bedded reservoirs on the monoclines or on the flanks of anticlines. These traps may contain rather large accumulations. They may be associated with bedded reservoirs confined on every side. In such a case, they form large accumulations. Water saturation contours impinge on the trap (impermeable barrier). This type of accumulations is very common: about 50% of all known accumulations.

Accumulations of Types I, II, and III are formed in accordance with the gravitational (“anticlinal”) theory. By far, not all known accumulations, however, belong in the described three types or combinations thereof. Also, not all of them formed in accordance with the gravitational theory. These unconventional accumulations are discussed below (Types IV through VII).

- IV. *Dominance of capillary forces over the gravity force.* Oil or gas found in hydrophilic rocks occupy coarser-grained reservoir rocks, which are sealed by water-saturated fine-grained reservoir rocks. Examples of such accumulations associated with the relatively coarse-grained sandstone lenses (e.g., 100-ft sandstone in Appalachian oil and gas province, USA) were presented by Brod (1957). The authors of this book reviewed large number of commercial accumulations all over the world and have not been able to find another such clear-cut example. Although the appearance of capillary forces is frequently observed, the formation and preservation of the accumulations cannot be attributed to these forces. It should be kept in mind that water and gas lenses exist within oil accumulations; water is sometimes encountered updip in pinched-out reservoirs (e.g., Productive Series of the Absheron Peninsula in Azerbaijan, and Maykopian sandstones in the Northwest Caucasus).
- V. *Dominance of hydraulic forces.* The hydraulic forces (Fig. 10.12) can cause a tilt in the oil–water interface. To determine that tilt, a trigonometric function (see

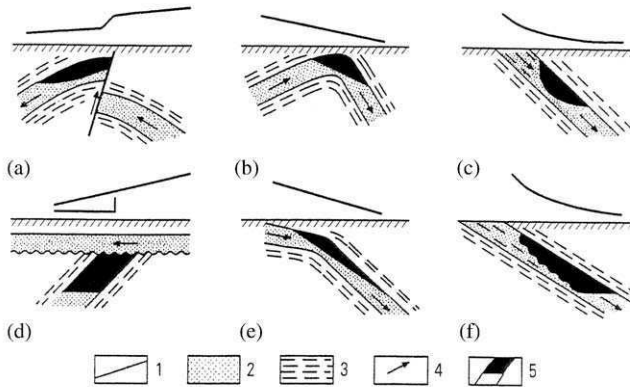

Fig. 10.12. Conceptual cross-sections of hydraulically trapped oil and gas accumulations. (a) Next to the conductive faults. (b) At the anticlinal crest. (c) In monoclines within the areas of changing reservoir properties. (d) In monoclines underneath the stratigraphic unconformities. (e) At structural noses of monoclines. (f) Near the reservoir shale-out boundaries. 1 – Piezometric surface; 2 – reservoir; 3 – shales; 4 – direction of water movement; 5 – oil and gas accumulations.

Chapter 4) or the Savchenko's (1977) equation could be used:

$$\Delta h = \Delta p_{\text{norm}} / g(\rho_{\text{water}} - \rho_{\text{oil}}) \quad (10.1)$$

where Δh is the amount of shift at the edge of accumulation, Δp_{norm} is the difference in normalized pressures, ρ_{water} and ρ_{oil} are the density of water and oil, respectively, and g is the gravitational acceleration.

A barrier (facies change, stratigraphic unconformity, and fault) often turns out to be a barrier due to the presence of pressure difference across it, rather than because of the appearance of an impermeable barrier in the way of fluid movement.

Fig. 10.12 shows possible relations of the positions of the piezometric surface (normalized pressure head) and the positions of the oil–water contact. The necessary condition for the preservation of hydraulically trapped accumulation next to a fault is a higher potential head of the water next to the fault zone than that of the productive formation (the surplus pressure is included). This condition may exist if, for instance, there is a communication along the fault between the accumulation and the reservoir with AHFP (overpressure).

In monoclines, the accumulations can be preserved (see Fig. 10.12c,e and f) if the potential head decreases downdip in locations where the dip increases (see Fig. 10.12e) or the dip of the piezometric surface decreases (see Fig. 10.12f). The latter is possible when the reservoir–rock properties change (i.e., capillary forces enter into play). The oil–water contact can close onto themselves (but crossing the structural contour lines on the top of the reservoir) or can about the trapping barrier. (The contributions of Plotnikov, 1976; Gattenberger, 1984; and Mikhaylov, 1984, on hydrodynamic traps are noteworthy.)

Neither of the described types, however, owes its existence to the hydraulic forces exclusively. They can exist only under condition of the combined interaction of several different forces: (1) hydraulic and gravity, (2) hydraulic and capillary, or (3) hydraulic + capillary + gravity forces. The effect of hydraulic forces is commensurate with that of gravity and capillary forces.

VI *Gas accumulations in synclines or in monoclines devoid of structural highs.* Examples of such accumulations have been presented by Masters (1979) and Perrodon (1984). There is a gas accumulation in the Deep Basin monocline in Alberta, Canada. The latter accumulation resides in the Mesozoic sandstone, which is more than 3 km high (the thickness of individual gas intervals is 10–150 m). The sandstone is water-saturated updip the gas accumulation, with an improvement in petrophysical properties. The gas reserves here are nearly 11.3 TCM. The gas accumulation of Milk River Field (Canada), with 250 BCM of reserves, is another similar example. The gas accumulation of San Juan Field (USA) resides in the Mesozoic sandstone in the synclinal part of the structure, with reserves of 700 BCM. The sandstone is water-saturated over the flanks. The porosity and permeability within the gas-saturated portion are 14% and 1 mD, respectively, whereas in the water-saturated portion, $\phi = 25\%$ and $k = 100$ mD. To explain this phenomenon, the following two explanations may be suggested:

- (1) A rapid gas generation is currently occurring in the Mesozoic sandstones of the Milk River and San Juan fields at a temperature of 85–92°C. This gas is entering the reservoir at a higher rate that it is being removed from the reservoir.
- (2) The reservoir rocks are hydrophobic (Bolshakov, 1986). Capillary forces move the gas into the reservoir with finer pores and keep it there.

The authors of this book believe that both explanations are questionable, because of the high surplus pressure and high capillarity within the water-saturated portions of the accumulation. In the case of the first explanation above, if the gas-saturated reservoirs are intercommunicated and form a single accumulation, the surplus pressure in its upper portion should be around 30 MPa. If $\phi = 25\%$ and $k = 100$ mD, the effect of capillary forces would be negligible and insufficient for retaining the accumulation. Also, if the porosity and permeability values are low along the axis of syncline, a high rate of gas input would be doubtful.

The two explanations above assume that the gas is retained due to the change in rock properties. In the first explanation the fast gas input from clays is assumed (and from a larger area than the gas escape area). The second explanation subscribes to the action of capillary forces in hydrophobic rocks. It is quite possible, however, that the fluid properties change together with the changes in the reservoir–rock properties. A prolific gas generation occurred (and may still be occurring) in the Mesozoic sequence. The gas dissolves in water as soon as it is formed. Thus, the gas-saturated water enters the reservoir. In this case, the surplus pressure within the upper portion of the accumulation would be tens of times lower than that for the gas accumulations [the difference would be $(\rho_{\text{water}} - \rho_{\text{gas}})$ in one case and $(\rho_{\text{water}} - \rho_{\text{emulsion}})$ in the other case]. Updip, the pore size increases (as indicated by the higher porosity and permeability), the capillary pressure and temperature

decline, gas solubility in water drastically decreases (depending on changes in the reservoir conditions), and gas is released as a free phase forming a gas-in-water emulsion. A substantial portion of the released gas energy is spent for the formation of emulsion. The emulsion has huge surface area and, correspondingly, huge surface energy. Thus, the gas accumulation is insulated by the gas-in-water emulsion, which is only slightly movable and is elastic at reservoir conditions.

Three major reasons have been proposed in the above three explanations to elucidate the formation and existence of the accumulations: (1) the difference in the speeds of immigration and emigration, (2) the capillary forces (and wettability), and (3) changes in the fluid properties due to changes in the formation temperature and pressure.

The problem is yet to be solved. How common are such (Type VI) accumulations? What is their contribution to the total undiscovered resources? At this time there is no answer to these questions. The existing exploration, testing and production techniques are attuned almost exclusively to the accumulations where the gravity forces predominate. Discoveries of Type VI accumulations in such conditions is highly accidental. Their exploration, testing and production techniques must be established after the known accumulations of this type are studied in detail.

VII *The “critical-state” accumulations.* The “critical-state” accumulations have been described above. It is important to emphasize again that the name is tentative. May be they should be called “near-critical to critical” accumulations.

10.5. VERTICAL ZONATION OF HYDROCARBON ACCUMULATIONS

A commonly accepted definition of an “oil and/or gas field” is still missing. Commonly, a field is defined as all oil and/or gas accumulations (pools) associated with some structural feature of the Earth’s crust (see Eremenko, 1991). The authors of this book define an oil and/or gas field as an area of the Earth’s crust that contains accumulations (pools) of oil and/or gas, the lateral extent of which is amenable for arranging the infrastructure to develop the field in its totality. On the other hand, the term “pool” refers to any elementary, single accumulation of oil and/or gas.

This definition of a field is quite different from the one previously proposed by one of the authors (Eremenko, 1968, 1984). The new definition encompasses not only all accumulations, but also the entire rock sequence comprising the field (including “dry”, i.e., water-saturated, hydrocarbon-free formations). Knowledge of this information is of decisive importance for the development of a field. When the accumulation characteristics are known, one can select the main target, the intervals for joint production, and the intervals for the injection of produced water.

There may be an accumulation located on the flank of monocline far from the rest of accumulations. Such an accumulation, depending on the development environment, may be treated as part of the same field or considered as a separate field. The vertically overlapping accumulations, which belong to different structural elements, are included in the same field. Such different structural conditions may include abrupt unconformities, e.g., monocline over an anticline, rootless anticline over a

monocline, or overthrusts and underthrusts. Therefore, “field” is not just a geologic term but rather a geologic–technologic one. (See Kontorovich et al., 1975.)

An oil and/or gas field should be characterized first of all by the geological structure of the area it is located in and by the types of traps. Usually, some additional information to characterize the field is provided including:

- location of the area relative to larger regional structures of the Earth’s crust;
- the presence of different structural stages within the field;
- the number of accumulations;
- the amount of reserves and their density over the area;
- hydrocarbon phase state in the accumulations;
- vertical zonation of hydrocarbon distribution;
- subsurface temperature and pressure; and
- the number of target reservoirs.

There are numerous classifications of the local tectonic structures, including some specifically petroliferous. The following are the most important parameters of the classifications:

- (1) Almost all classifications are based on general tectonic characteristics commonly accepted as of the date of classification. They include the location of structures: (1) the oceanic, continental or transitional crust; (2) the platform or geosyncline; (3) the center or margin of a tectonic plate; and (4) the divergence and convergence zones.
- (2) In all classifications, the formation of crustal element associated with hydrocarbon accumulation is treated in the context of evolution of the Earth’s crust as part of the lithosphere (sometimes, asthenosphere and rarely, mantle).
- (3) Some structures of “cosmic” origin (meteorite impact structures) have been found to be petroliferous. Donofrio (1981) stated that there are at least 3000 impact craters greater than 10 km in diameter on the Earth’s surface. King (1979) described an impact structure as follows: An external circular swell is comprised of loose rocks, which can form a good reservoir rock upon burial. Bedrock underneath the swell is fractured. The internal depression is usually filled up with breccia. In some cases, the depression may have a central high or a ring structure surrounded by a circular depression. The rocks underneath the crater are usually compacted and form a graben.

Donofrio (1981) considered the Newfield accumulation (USA) an impact structure in the Carboniferous sediments. The diameter of swell is 5–6 km. An oil accumulation (with about 17 million barrels of recoverable reserves) is found in the breccia of the crater. The Red Wing Creek Field accumulation of Ordovician age (40–70 million barrels of recoverable reserves) resides in the breccia of central high, 6.5 km in diameter.

A significant number of ring structures were discovered recently as a result of surveys from space. Their origin is not clear. Some of them may be impact structures, whereas most of them are probably of deep-seated origin. Attempts by some geologists to relate the distribution of hydrocarbon fields to rings are premature. The assumption that the hydrocarbons migrated from the great depth in the Earth are speculative.

Significant features of an oil–gas field include characterization of the rock sequence (see Chapter 2), distinct expression of the structure, and complexity of the structure. Obviously, this characterization depends on the geologic evolution of a specific region. The latter, in turn, is defined by the tectonic processes.

A structural element can be defined by its height and the steepness of its flanks. The height is the difference in depth from the highest point of structure to the spill point. The structural height controls the accumulation column, the possible gravity differentiation of fluids in the accumulations, maximum values of the surplus pressure, and the possibility of accumulation being “squeezed-out” from the trap (Chapter 3). The steepness of flanks first of all affects the gravity buoyancy force (f) up the reservoir:

$$f = g\Delta\rho \sin \alpha \quad (10.2)$$

where g is the gravitational acceleration, $\Delta\rho$ is the difference in the density of fluids, and α is the dip angle.

Difference between the density of hydrocarbons (oil and/or gas) and that of water in a reservoir can create an overpressure (Fig. 10.13). Obviously, in the case of gas, the overpressure will be more pronounced.

The structural complexity of the area, where the hydrocarbon field is located, very significantly affects the natural and technical conditions of the field. The natural conditions are characterized by the formation and existence (within a specific area of the Earth’s crust) of different hydrocarbon accumulations (different in terms of type, shape, and fluid content) and their possible interrelations. The technical conditions encompass the exploration, appraisal, testing, and production techniques. They also depend on the geologic structure, including the characteristics of the rocks enclosing the hydrocarbon accumulation, as discussed in Chapter 2.

One of the primary characteristics of the field is the number and type of deposits. The number of deposits and their grouping among the separate structural elements of the field (if they are clearly distinguishable) define the basis for the appraisal and development of productive formations. The grouping of latter is necessary for planning commingled production and possible recompletions. The hydrocarbon reserves and their commercial category must be determined for each field. Frequently, the “specific density of reserves” (tons of oil or cubic meters of gas per 1 km^2 of the field area) is used to characterize hydrocarbon fields. The higher the specific density, the more efficient the field development (field facilities and the efficiency of their utilization).

Several zones may be identified in the vertical section of each field, on the basis of the oil and gas occurrence. The authors of this book propose to distinguish five vertical zones on the basis of temperature, pressure, and phase relationships (Table 10.4).

The depth boundaries in Table 10.4 are very tentative, because they depend on the quality of fluids and the nature of heat flow. Temperatures are not specified, because they will change for the selected depth and pressure intervals, depending on the heat flow. Zone 3 is within the critical pressure range for water. In the case of a “stretched” heat flow, the temperature even at a depth of 4.5–5 km may be just

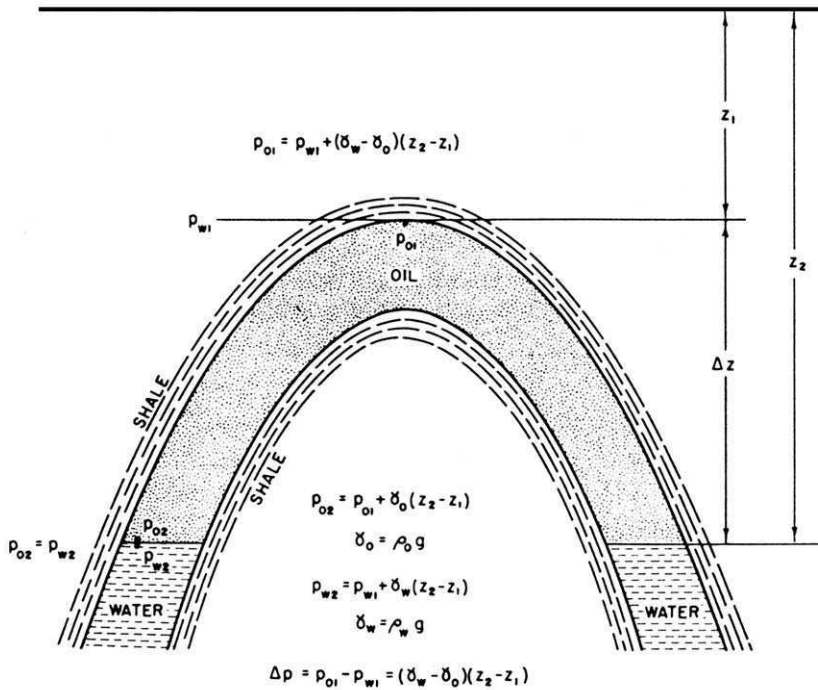

Fig. 10.13. Cross-sectional view of an anticlinal reservoir sandwiched between two impervious shale bodies, showing abnormal pressures in hydrocarbon accumulation in hydrostatic water environment. γ_o = specific weight of oil (e.g., in lb/ft^3); γ_w = specific weight of water (e.g., in lb/ft^3); z = elevation (e.g., ft); p = pressure (e.g., in lb/ft^2); overpressure [$\Delta p = (p_{o1} - p_{w1}) = (\gamma_w - \gamma_o)(z_2 - z_1)$] in lb/ft^2 (modified after Hubbert and Rubey, 1959, p. 150; and Gretener, 1969, p. 267; in: Rieke and Chiligarian, 1974, Fig. 264, p. 310).

90–100°C (South Caspian Basin). Rough estimates, however, indicate that the temperature within Zone 3 is above 100–120°C and may increase to 160–180°C within Zone 4, and higher in Zone 5. The vertical zonation controls the possible depth of occurrence of crude oils with a certain phase composition and corresponding pressures (normal and abnormal) and the temperature, hence the oil and gas properties and the patterns of their change up the section.

Relationship between the pressure and depth is presented in Fig. 10.14. There are three different scenarios of the reservoir pressure change with depth:

- (a) Reservoir pressure changes according to the hydrostatic pressure gradient (Line I).
- (b) Within the intercommunicating accumulations, according to the surplus pressure gradient (Line II, which is always steeper than Line I).
- (c) Abnormally-high formation pressure (AHFP) (Line III, which is always flatter than Line I).

TABLE 10.4

Vertical zonation of oil and gas fields (After Eremenko and Chilingar., 1996, p.125.)

Zone	Approximate depth to the lower boundary (km)	Pressure (MPa)	Oil quality and pattern of changes	Mutual solubility of oil and gas	Drive mechanism	Gas composition in gas accumulations
1	0.5–0.8	5.5–9	Various combinations are possible; oxidized and weathered crudes having lost their light fractions are encountered.	Direct correlation. Associated gas becomes dryer with depth.	Combination of any drives is possible.	Dry gas dominates.
2	0.8–1.0	9–12	Lighter crudes	Weak inverse solubility is possible depending on the oil and gas quality.	Water drive is common in oil accumulations. Elastic drive is also observed.	Percentage of wet gas increases.
3	2–2.5	Normal up to 30, abnormal up to 35–40	Even lighter crudes with even higher content of paraffins	Inverse solubility becomes clearer with depth. Gas becomes more wet.	Water and depletion (elastic) drives are most common.	Condensate is common.
4	Up to 5	Normal up to 60, abnormal up to 100	Light condensate-type crudes dominate.	Same as above	Same as above	Condensate is always present
5	>5–7	>100	Mostly gas–oil or gas–oil–water solution	Single phase	Elastic drive	Gas–oil–water solution

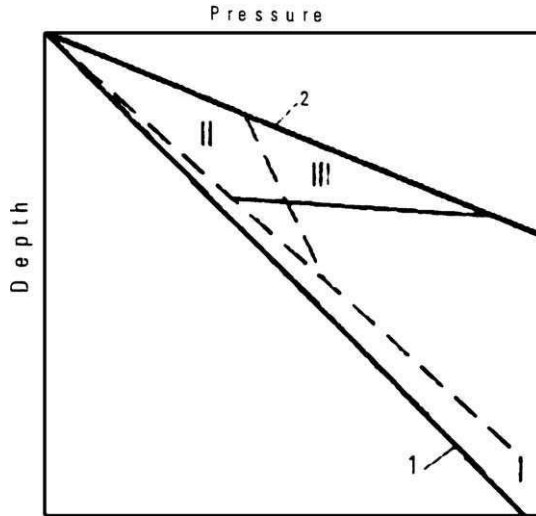

Fig. 10.14. Three major patterns of variation of formation pressure with depth. 1 – Hydrostatic pressure gradient ($\rho_w = 1 \text{ g/cm}^3$; 62.4 lb/cu. ft.; 0.433 psi/ft). 2 – total overburden pressure (1.0 psi/ft; 0.23 kg/cm²/m). I – Hydrostatic pressure gradient ($\rho_w = 1.25 \text{ g/cm}^3$); II – pressure change in communicating accumulation at overpressure; and III – abnormally high formation pressure. (After Eremenko and Chilingar, 1996, p.126.)

In the intercommunicating gas accumulations (e.g., massive accumulation of the Shebelinka Field, Ukraine), at $\rho \approx 0$ the Line I will be vertical. An increase in the AHFP along the Line III will result in the formation of fault-block reservoirs with different AHFP values.

From the locations of points in the graph, the connectivity of the productive horizons can be determined.

There are some examples (e.g., East Siberia) of abnormally low formation pressure (ALFP). These pressures are lower than the hydrostatic (Chilingar et al., 2002). Water in some parts of such formations is found in solid state (due to the permafrost), whereas in some other areas the water is not present at all. In the absence of water (ice instead of water), there is no hydrostatic piezometric surface.

This page intentionally left blank

*Chapter 11***MATHEMATICAL MODELING IN PETROLEUM GEOLOGY**

11.1. PRINCIPLES OF MATHEMATICAL MODELING OF GEOLOGIC SYSTEMS

Exploration, development, and production of hydrocarbon resources must be based on reliable information, which helps to predict the subsurface conditions and properties of the oil- and gas-bearing formations. Consequently, both mathematical modeling of the processes of deposition and evolution of sediments and concurrent development of mathematical procedures for predicting reservoir pressures, oil and gas composition, and petrophysical properties of reservoir rocks and seals are the goals of high priority. The increase in depth of oil and gas occurrence with consequent increase in the complexity of geological and environmental conditions that affect the exploration for oil and gas, as well as development of new on- and offshore fields requires application of a set of mathematical models to process geological, geophysical, geochemical, and engineering data. This will aid in exploration, estimation, and evaluation of oil and gas resources, and to achieve an efficient oil and gas field development and production (Miller and Kahn, 1965; Krumbein and Graybill, 1969; Krumbein et al., 1973; Harbaugh and Bonham-Carter, 1974; Rodionov et al., 1987).

The use of mathematical methods and computer techniques increases the scope of problems that can be solved on the basis of integrated geological, geophysical, geochemical, and engineering information. Mathematical methods with computer processing of the current information accelerate the process of regional and local prediction of oil and gas potential, that, in general, increases the economic and geologic efficiency of exploration, development, and production of oil and gas fields (Buryakovsky et al., 1982, 1990, 1991; Buryakovsky and Agamaliyev, 1990; Buryakovsky, 1992).

In the field of petroleum geology, the discovery and development of oil- and gas-bearing basins, regions, zones, fields, etc. may be considered as dealing with integral geologic systems, the evolution, structure, and behavior of which can be predicted. Geologic system may be defined as follows:

Geologic system is a well-organized natural assembly of interconnected and interacting elements of lithosphere having common development history and comprising a single natural unit with properties that are not inherent in its individual elements.

An important feature of these systems in petroleum geology (i.e., basins, regions, zones, fields, etc.) is that division into subsystems of (1) reservoir (permeable) rocks and (2) sealing (impermeable) rocks is possible. The presence of these two subsystems defines oil and gas reservoir or trap. Absence of any one of these subsystems (reservoir rock or seal) indicates the absence of reservoir or trap.

Geologic systems of oil- and gas-bearing basins, regions, zones, fields, etc. are parts of the more extensive systems in the Earth's crust. Owing to the absence of

distinct boundaries, these systems exchange matter, energy, etc. with the external medium. The geologic systems also develop in time. They, however, provide the certain stability and inherit main structural and behavioral features of the system. Depending on the kind of exchange between the geologic system and external medium (exchange of substance, energy, or information, separately or simultaneously), one can construct various types of models of oil- and gas-bearing systems. The classification of the main features of natural geologic and engineering-technologic systems is shown in Fig. 11.1.

The systems' approach to geology is both a sophisticated philosophy and a scientific method for investigation of very complicated geologic systems. As applied to petroleum geology, it includes the methodological base and technology of mathematical simulation used for modeling geologic systems, the systems, which have been previously investigated and estimated by using experimental or field data. Inasmuch as geologic systems develop in time, it is very important to simulate them as dynamic systems. The necessity of taking the geologic time factor into consideration does not eliminate the possibility of developing, along with the dynamic models, also of the static and structural models. It is imperative, however, to remember that geology is a historic discipline, and the relative lack of success in its mathematization is associated to a significant degree with difficulties in taking into consideration the time factor.

Scientific bases, simulation techniques, and mathematical models of both static and dynamic geologic systems have been developed, and basic theoretical and methodological principles of simulation and prediction of geologic systems (their structure and behavior) have been defined (Buryakovsky, 1992). These principles are as follows:

1. Principle of consideration of the system's nature requires a separate simulation of geologic, technologic, and experimental systems with different objectives required by the "real world".
2. Principle of system's development (evolution) requires the simulation of systems considering the time factor and its subdivision into three time scales: (a) geologic, (b) technologic, and (c) experimental.
3. Principle of consideration of comparative size and complexity of geologic, technologic, and experimental systems requires simulation of a sequence of systems from an oil- and gas-bearing basin through oil and gas field to core sample scale.
4. Principle of consideration of the information growth requires simulation of the activities of earth scientists. These include the successive phases of prediction of oil and gas presence and existence of traps, and discovery, exploration, reserve estimation, development, and production of oil and gas fields.

The definition of these principles provides the systems' approach both in the development of the scientific foundations and in the simulation technology of geologic systems. The relations among simulation principles are given as a flowchart in Fig. 11.2. An important element of this chart is the feedback, which allows improving the present and developing the new methods for investigation and simulation of geologic systems.

The technological chart (Fig. 11.3) distinguishes three inlet blocks: (1) theoretical foundations (basic principles), (2) initial information, and (3) technical means

		Distinctive features of systems used in classification																												
		System origin		System size			System complexity		Time dependence		Exchange w/ambient environment by	Type of system isolation	Type of available information	Type of system description																
Subclasses	Classes	Natural	Technological	Scientific/engineering	Technical/economic	Sub-local	Local	Super-local	Sub-global	Global	Super-global	Very simple	Simple	Complex	Very complex	Static systems	Dynamic systems	Matter	Energy	Information	Open systems	Closed systems	Totally confined systems	Qualitative	Quantitative	Deterministic	Stochastic	Mixed		
																													Natural science	Engineering
Intermittent	Continuous	Cyclic	Stable	Self-evolving																										
																													Incomplete	Complete

Fig. 11.1. Classification of natural-geologic and engineering-technologic systems.

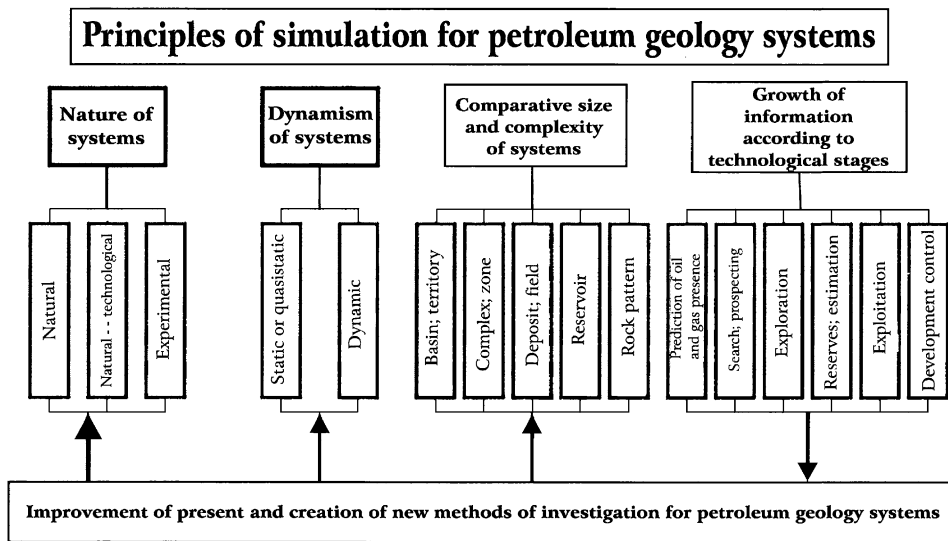

Fig. 11.2. Flowchart of interrelations between information and principles of modeling petroleum geology systems. Solid lines: directions of substance, energy or information flow; bold lines: directions of feedback information flow.

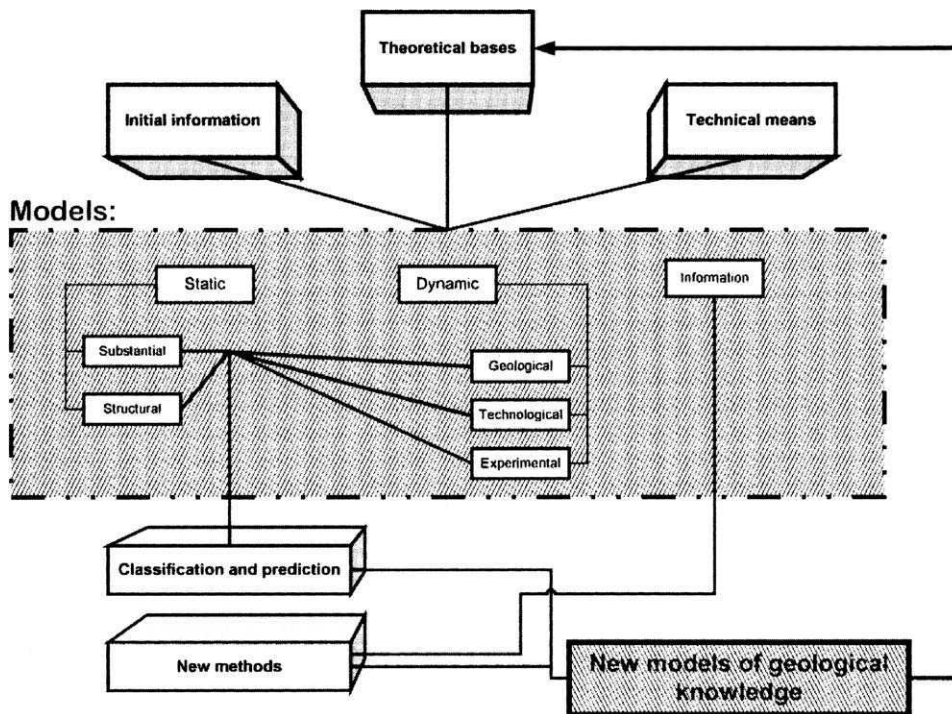

Fig. 11.3. Flowchart of modeling petroleum geology systems.

(facilities). This chart also contains the feedback, which provides improvement of theoretical foundations for the simulation of geologic systems.

11.2. MODELS OF STATIC GEOLOGIC SYSTEMS

With increasing depth of exploration, one of the major problems is the estimation of influence of natural factors (total overburden, pore (fluid) and effective pressures, reservoir pressure, formation temperature, lithology, pore space geometry, etc.) on the properties of sedimentary rocks and formation fluids (lithofluidal system). The lithofluidal system can be defined as follows:

Lithofluidal system is the well-organized natural assembly of interacting solid, liquid and gaseous elements of lithosphere having common development history and a distinguishing set of physical and chemical properties, which manifest themselves both individually and jointly.

Mathematical models of the processes which describe the influence of pressure, temperature, and structural and lithological factors on the properties of sedimentary rocks and formation fluids can be presented using two approaches: deterministic (analytical) and probabilistic (statistical). Both of these approaches are mutually dependent and their combination enables the generalization of studied processes.

Statistical methods can be used only in the case of the existence of sufficient data. These data are obtained either at the stage of completion of exploration or during subsequent development of a deposit. Obtaining the representative data can be very expensive. Therefore, new procedures should be developed for prediction of rock and fluid properties when data are sparse. Such studies are especially appropriate for the exploration and development of oil and gas fields, which occur at great depths or in harsh environments. At the latter case, the problems of drilling, coring, testing, and logging do not allow the acquisition of reliable data for the evaluation of reservoir rock and caprock properties, and formation fluid properties, especially at the early stage of exploration.

The main principles used in mathematical simulation are as follows:

1. The most complete quantitative characteristics of the geological, geophysical, and geochemical parameters are described by their statistical distributions.
2. The distributions of geological, geophysical, and geochemical parameters are simulated on the basis of their mathematical descriptions (models), which may be probabilistic or deterministic.
3. In the case of scarcity of data, the artificial distributions of model input data are formed by means of their interval-probable presentation, and the Monte Carlo technique is used for plotting such distributions.
4. For the purposes of predicting properties of rocks and formation fluids, simulation of statistical distributions is required on the basis of models with variable input data depending upon changes in the regional geologic environments.
5. For the purposes of identification of formations, simulation of more than one statistical distribution and the determination of the cut-off points for the simulated parameters (which allows strata classification) are required.

The characteristic feature of construction of artificial distributions for solving geologic modeling problems is that the decision about the influence of various natural factors upon the parameter under study is often made only at the range of their variation, which indicates the presence of fuzzy data sets. In such a case, the interval-probable determination of the input data and the subsequent calculation results provide consideration of the indeterminate form of the basic factors.

11.2.1. Analytical approach

11.2.1.1. Entropy of geologic systems

A study of geologic systems, from the viewpoint of homogeneity/heterogeneity of their structure, may be carried out with an aid of the theory of information. Any communication is a sum total of information on some real system. In geologic terminology, such may be the reports on the various analyses of rocks, oils, gases, and formation waters, which have been conducted in the laboratory or obtained from formation testing. Any one of these communications describes the state or level of knowledge of some geologic system.

The entropy, a special index in the theory of information, is employed as a criterion of the *a priori* (before the communications were received) indefiniteness of the system. The concept of entropy, borrowed from the thermodynamics and statistical physics, is a basic concept in the theory of information. The entropy, H , is determined by the following formula:

$$H = - \sum_{i=1}^N p_i \log p_i \quad (11.1)$$

where p_i is the probability of state of any one of the N components constituting the system. The "minus" sign is introduced in order to make the entropy positive, inasmuch as $p_i \leq 1$ and $\log p_i \leq 0$.

The H entropy is related to the S entropy (commonly employed in thermodynamics) using the Boltzmann's constant k , namely:

$$S = -k \sum_{i=1}^N p_i \log p_i \quad (11.2)$$

The entropy has the following properties:

(1) It becomes zero, if one of the states of the system is fully known ($p_k = 1$) and the others are impossible ($p_1 = p_2 = \dots = p_{k-1} = \dots = p_n = 0$).

(2) At a given number of states, it becomes maximum, if all the states are equally probable, but increases with the increasing number of states.

(3) It is additive, i.e., it is possible to add up entropy of different systems.

In the theory of information, entropy is generally calculated in the binary system, although natural or decimal logarithms are often more convenient to use. The shape of the $-p \log p$ function, in natural and decimal logarithms, is presented in Fig. 11.4.

The quantity of information on the state of a real system is measured by the decrease in the entropy of this system. The ultimate quantity of the information, I , is equal to H (the total entropy of the system), namely

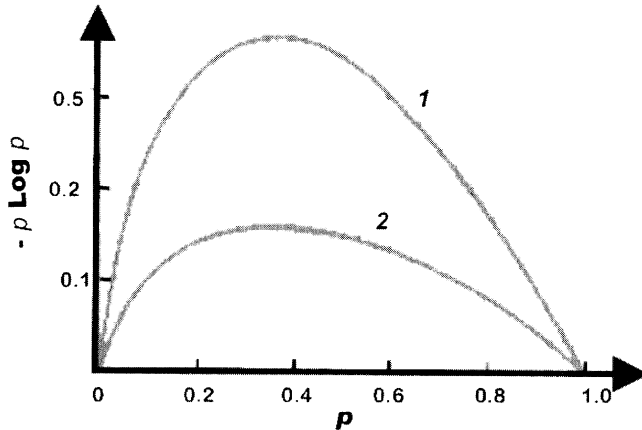

Fig. 11.4. The $-p \log p$ function plotted against p in (1) natural and (2) decimal logarithmic scales.

$$I = - \sum_{i=1}^N p_i \log p_i \tag{11.3}$$

Thus, the information I is the logarithm of probability of the general state, with the reverse sign, weighted with respect to every state of the system. The information may be recorded also as a mathematical expectancy:

$$I = M[- \log p_i] \tag{11.4}$$

If the states of the system have different probabilities, the information, by the different communications, will not be equal. The fullest information is borne by the communications about events, which are the least probable, *a priori*. The entropy of a system increases with increasing indefiniteness of the system. In a fully definite system (of which everything is known or which has the highest orderliness), the entropy equals zero. Chaotic state, disorderliness, lack of sorting, heterogeneity, or indefiniteness of the state increase the entropy of the system.

Consequently, magnitude of entropy, which expresses the degree of heterogeneity or indefiniteness, may be used in geologic studies and graphic representations of heterogeneity of various geologic systems. For example, zones with characteristically high entropy (low information capacity) (i.e., zones where different facies are mixed in approximately equal proportions) in facies maps will differ from areas occupied by limited number of facies with high information capacity (smaller entropy). In the case of a zone containing one facies only, the entropy of the system is equal to zero and the information is at a maximum.

Relative entropy is the ratio of determined entropy to the maximum entropy, obtained for a given number of components,

$$H_r = \left(- \sum_{i=1}^N p_i \log p_i \right) / H_{\max} \tag{11.5}$$

where H_r is the relative entropy, H_{\max} is the maximum possible entropy, and p_i is the fraction (probability) of the i th component of the N -component system.

The H_{\max} is determined as follows:

$$H_{\max} = - \sum_{i=1}^N (1/N) [\log(1/N)] = \log N \quad (11.6)$$

The H_r (even as H entropy) becomes maximum when all the component fractions are equal to each other, and becomes minimum when one of the components is certain and the others are impossible.

The relative entropy, H_r , is convenient in quantitative studies and graphic representations of relative heterogeneity of multicomponent systems. It may be employed in investigations of heterogeneity of sediments and rocks, laterally or vertically, as well as in the studies of ternary mixtures encountered in lithology, geochemistry, and hydrochemistry, for example. A triangular diagram of a three-component mixture with relative entropy contours is presented in Fig. 11.5. A point within the triangle will be represented by a number expressing the degree of heterogeneity of the system. The maximum relative entropy ($H_r = 1$) lies in the center of the triangle and the minima ($H_r = 0$) at the apexes.

A quantitative rating of the heterogeneity of different types of clastic rocks can be made using this triangle. The classification diagram of clastic rocks includes eight major types (Fig. 11.6): (1) sand, (2) silty-clayey sand, (3) sandy-clayey silt, (4) silt, (5) sandy-silty-clayey rock, (6) clayey-sandy silt, (7) silty-sandy shale, and (8) shale. The most homogeneous ones (sand, silt, or shale) have the relative entropy of 0.45. The least homogeneous rocks (silty-clayey sand, sandy-clayey silt, clayey-sandy silt, and silty-sandy shale) have the relative entropy of 0.78. Unsorted rocks have the relative entropy of 0.83–0.85 depending on the clay content; loam, 0.90; and a mixture of equal proportions (by wt) of sand, silt, and clay, about 1.

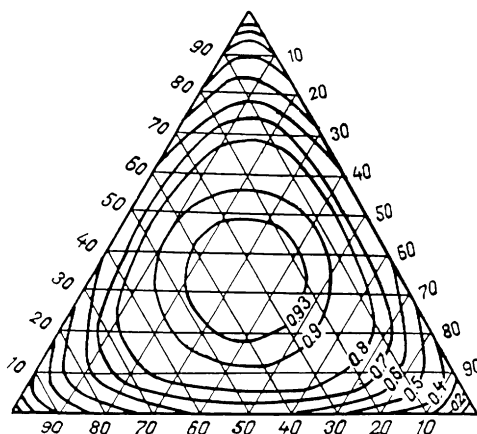

Fig. 11.5. Relative entropy of ternary mixture.

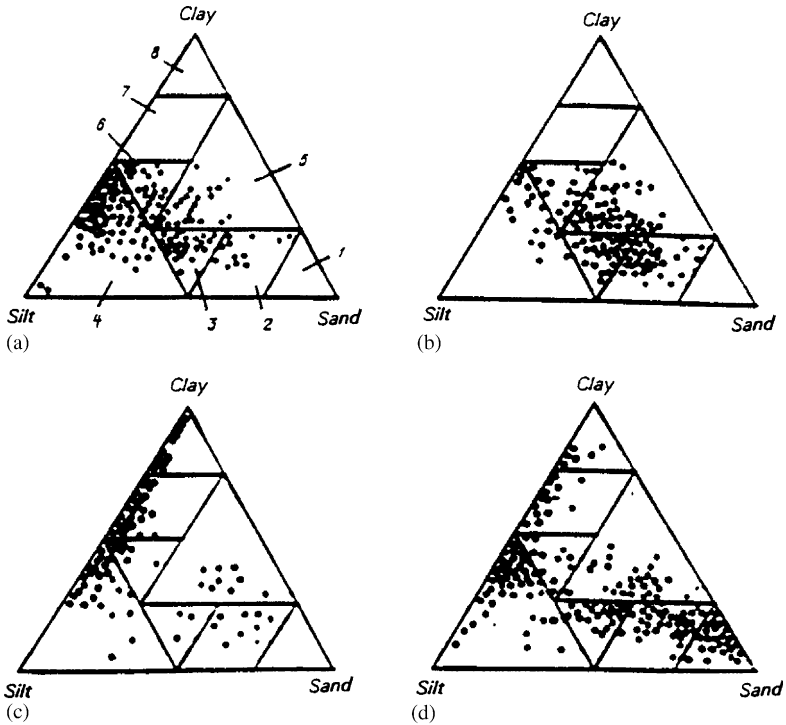

Fig. 11.6. Classification of Kirmaku (a, c) and Podkirmaku (b, d) clastic rocks in SE (a, b) and NW (c, d) parts of Absheron Archipelago, Azerbaijan (after Buryakovskiy et al., 2001). 1 – sand, 2 – silty-clayey sand, 3 – loam, 4 – silt, 5 – unsorted sediments, 6 – clayey-loam, 7 – sandy-silty shale, 8 – shale.

Thus, on the basis of their heterogeneity, the rocks can be classified and rated quantitatively. A rock with the relative entropy below 0.5 can be considered as a very homogeneous one, composed of grains of about similar size. The poorly sorted rocks have a relative entropy higher than 0.5.

In calculating the entropy, only the frequencies (probabilities) of every component of the system are taken into account; the absolute magnitudes of the components are not considered. This may be a shortcoming when the properties of a mixture depend upon the absolute contents of its components (or of their ratios); for example, where the porosity of a mixture depends not only on the proportions of various fractions in the rock, but also on the mean diameter of the grains in every fraction. In such a case, the most heterogeneous rocks, with the lowest porosity, will not fall in the center of the triangle but will be somewhere between the fractions with the largest and smallest mean diameters of grains.

The merit of rating the indefiniteness or heterogeneity of a real system by means of its entropy lies in its quantitative expression by one single number and not by several numbers (three or even more).

The use of relative entropy has another advantage, because its magnitude has the upper and lower limits ($0 \leq H_r \leq 1$). The other parameters of heterogeneity of a

system (range of variation, scattering, variations coefficient, etc.) have no upper limit, so that the use of relative entropy makes it possible to rate the heterogeneity of a rock without resorting to comparisons with the other parameters of heterogeneity.

As an example of application of the relative entropy in rating the heterogeneity of rocks, the grain-size composition of rocks of the Kala Formation of the Absheron oil and gas region of Azerbaijan was analyzed. The most homogeneous portion of this formation was found in the Gum Deniz and Turkyany areas, whereas the least homogeneous portion was present in the Karachukhur–Zykh area and in the south-eastern part of the Absheron Archipelago. As determined from cores, the grain-size heterogeneity (or microheterogeneity) of the various rock types (see Fig. 11.5) indicates that the relative entropy is increasing with heterogeneity increase. A general increase of the relative entropy, however, has no significant effect on variations in the relative entropy of the whole area.

Heterogeneity in individual deposits can be extended to the areal variations in lithology. Entropy contours are plotted on the map and then interpreted to decipher the paleogeography of the area, sedimentation scenario, and subsequent diagenetic and catagenetic alterations of sediments and rocks. For example, the homogeneity of the Kala Formation increases with increasing depth of sediment deposition (under a calm hydrodynamic regime) (Table 11.1).

With increasing burial depth in the Karachukhur–Zykh–Gousany–Gum Deniz–Turkyany anticlinal trend, the relative entropy progressively decreases. The entropy increases along the Gyurgyany Deniz–Chalov Adasi–Palchygh Pilpilasi–Neft Dashlary anticlinal trend. The relative entropy progressively decreases with burial depth in the offshore oil and gas fields of Absheron Archipelago. There is an inverse depth–entropy relationship between individual areas.

As far as the basic relationship in spatial distribution of H_r as a criterium of heterogeneity of the rocks is concerned, there is a decrease in H_r and a better sorting

TABLE 11.1

Evaluation of heterogeneity entropy for the Kala Formation of the Absheron Archipelago, Azerbaijan (after Buryakovsky et al., 2001)

Area	Number of reservoirs	Average depth (m)	Entropy	Relative entropy	
				Without microheterogeneity	With microheterogeneity
Gyurgyany Deniz	56	2160	1.580	0.72	0.83
Chalov Adasi	120	720	1.933	0.88	0.92
Palchygh Pilpilasi	59	1130	1.699	0.77	0.87
Neft Dashlary	170	1010	1.904	0.87	0.90
Karachukhur–Zykh	64	2790	1.816	0.83	0.91
Gousany	180	4010	1.597	0.73	0.80
Gum Deniz	25	3500	1.410	0.64	0.65
Turkyany	65	3760	1.423	0.65	0.67
Kala Formation as a whole	746	—	—	0.71	0.76

of rocks with increasing depth. This relationship is typical for both the individual anticlinal zones and for the entire area of sedimentation during the Kala time.

Thus, the conclusions can be summarized as follows:

1. Entropy of a geologic system may serve as a criterion of its heterogeneity. This makes it possible to use entropy as a quantitative rating of heterogeneity of rocks.
2. Relative entropy is a convenient measure of heterogeneity of rocks and can be calculated using natural logarithmic tables.
3. Heterogeneity of different rocks with respect to their grain-size distribution, and heterogeneity of formations with respect to the proportions of different rock types in the section, may be expressed in entropy values.
4. In studying the heterogeneity of sediments, the concept of entropy may prove to be useful not only in the fields of lithology and petrography, but also in the fields of geochemistry and hydrochemistry.

11.2.1.2. Anisotropy of sedimentary rocks

The migration and accumulation of hydrocarbons in stratified heterogeneous deposits differ from those in massive homogeneous reservoirs. The fluid motion in various directions is subject to a considerable anisotropy, because the permeability of the stratified rocks is dependent on the direction of flow. One needs to determine the anisotropy coefficients for such rocks in order to simulate hydrodynamic scenarios.

For a three-component medium composed of layers of (1) good-quality reservoir rocks, (2) low-quality reservoir rocks, and (3) non-reservoir rocks, the permeabilities can be expressed as follows:

$$k_2 = \alpha k_1 \quad \text{and} \quad k_3 = \beta k_1 \tag{11.7}$$

where k_1 , k_2 , and k_3 are the permeabilities of the above three classes of rocks, respectively, whereas α and β are empirical factors which are less than 1.

The initial equations for the permeability parallel (k_{\parallel}) and perpendicular (k_{\perp}) to the bedding, using Eq. 11.7, are as follows:

$$\begin{aligned} k_{\parallel} &= (k_1 h_1 + \alpha k_1 h_2 + \beta k_1 h_3) / (h_1 + h_2 + h_3) \\ &= k_1 (h_1 + \alpha h_2 + \beta h_3) / (h_1 + h_2 + h_3) \end{aligned} \tag{11.8}$$

and

$$\begin{aligned} k_{\perp} &= (h_1 + h_2 + h_3) / (h_1 / k_1 + h_2 / \alpha k_2 + h_3 / \beta k_3) \\ &= k_1 (h_1 + h_2 + h_3) / (h_1 + h_2 / \alpha + h_3 / \beta) \end{aligned} \tag{11.9}$$

where h_1 , h_2 and h_3 are the thicknesses of layers of good-quality reservoir rocks, low-quality reservoir rocks, and non-reservoir rocks, respectively.

The anisotropy coefficient can be expressed as follows:

$$\lambda = (k_{\parallel} / k_{\perp})^{1/2} = [(h_1 + \alpha h_2 + \beta h_3) (h_1 + h_2 / \alpha + h_3 / \beta)]^{1/2} / (h_1 + h_2 + h_3) \tag{11.10}$$

or in terms of relative thicknesses,

$$\lambda = [(h_1^o + \alpha h_2^o + \beta h_3^o)(h_1^o + h_2^o/\alpha + h_3^o/\beta)]^{1/2} \quad (11.11)$$

where $h_i^o = h_i / \sum h_i$ and the h_i^o is the relative frequency of a layer having the permeability k_i .

The last two equations show that the anisotropy coefficient is dependent on the ratio of strata with a given thickness to the total thickness and on the empirical factors. Inasmuch as the anisotropy coefficient is dimensionless, it is dependent on the ratios of permeabilities and not on the permeability themselves.

The empirical factors α and β are constant for each particular formation or a group of similar formations as a whole. For example, on assuming that $k_{1\text{ave}} = 61$ mD, $k_{2\text{ave}} = 5$ mD, and $k_{3\text{ave}} = 0.5$ mD, $\alpha = 0.082$ and $\beta = 0.0082$, the values of k_i ($i = 1, 2, 3$) and α and β average out the theoretical values of λ . Measurements of λ , however, show that theoretically the thicknesses of the layer bands have the major effect. Therefore, if only the h_i for each stratigraphic–lithologic section is known, one can calculate the anisotropy coefficients from Eq. 11.10 or 11.11.

This conclusion can be extended to multicomponent and multilayer media, as shown by the following formulas:

$$\lambda = [(h_1^o + \alpha h_2^o + \beta h_3^o + \dots + \omega h_n^o)(h_1^o + h_2^o/\alpha + h_3^o/\beta + \dots + h_n^o/\omega)]^{1/2} \quad (11.12)$$

or

$$\lambda = \left[\sum_{i=1}^n (\alpha h_i^o) \sum_{i=1}^n (h_i^o / \alpha_i) \right]^{1/2} \quad (11.12a)$$

The median and the geometric-mean permeability is also used sometimes. From Eq. 11.7, for a three-component multilayer medium, the geometric-mean permeability (k_{geom}) is equal to

$$k_{\text{geom}} = (k_{\parallel} k_{\perp})^{1/2} = k_1 [(h_1 + \alpha h_2 + \beta h_3) / (h_1 + h_2/\alpha + h_3/\beta)]^{1/2} \quad (11.13)$$

or in terms of relative thicknesses,

$$k_{\text{geom}} = k_1 [(h_1^o + \alpha h_2^o + \beta h_3^o) / (h_1^o + h_2^o/\alpha + h_3^o/\beta)]^{1/2} \quad (11.14)$$

The geometric-mean permeability differs from the anisotropy coefficient in being dependent not only on the relative proportions of various strata and the empirical coefficients, but also on the mean permeability (the base permeability). Thus, k_{geom} retains the dimensions of permeability.

In the case of a multicomponent multilayer medium, k_{geom} is equal to

$$k_{\text{geom}} = k_{\text{ave}} \left[\frac{\sum_{i=1}^n (\alpha_i h_i^o)}{\sum_{i=1}^n (h_i^o / \alpha_i)} \right]^{1/2} \quad (11.15)$$

where k_{ave} is the average (mean) permeability of the reservoir. The h_i^o in Eqs. 11.12, 11.12a, and 11.15 is the relative frequency of any empirical factor.

The Balakhany Formation of the Productive Series of the South Caspian Basin was used as an example to show how the anisotropy was estimated. For this formation, 356 measurements of permeability were made with corrections for the formation pressure and temperature, because these rocks lie at a considerable depth (3500–4500 m). The permeability data were processed in order to determine the anisotropy coefficients, average permeability, and variation of anisotropy (Table 11.2).

The section of Productive Series of the South Caspian Basin is of rhythmic (cyclic) nature: at the bottom, the rhythmic (cyclic) strata consist of thick and continuous reservoir rocks with shale interbeds, whereas the reservoirs at the top are thin-bedded. Formations can be grouped on the basis of similarity in the thicknesses of individual layers. For example, one can combine formations at the base of the rhythmic strata with thickness ranging from 3 to 20 m (average = 8 m) into a single group. The top units, which are made up of the thin layers (thickness ranges from 2 to 12 m; average = 5 m), form another group. The anisotropy coefficients of thick beds are high ($\lambda = 4.4$), whereas $\lambda = 3.0$ for thin beds. The mean anisotropy coefficient for the entire Balakhany Formation is 3.9.

The value of λ allows one to determine the sequence of thicknesses of beds from thinner to thicker: the sequence can be based on anisotropy data obtained from logs and cores. For example, Von Engelhardt (1964, in: Buryakovsky et al., 2001, p. 300) presented laboratory results for the Dogger sandstones of Valanginian and Liassic age (from the oil and gas fields in the Northern Germany). In all cases, the permeability parallel to the bedding was higher than the permeability perpendicular to the bedding. On the average, the k_{\parallel}/k_{\perp} ratio was 1.9, which gives a mean anisotropy coefficient of 1.38. Mirchink's (1948, in: Buryakovsky et al., 2001, p. 300) data for sandstones in various USA oil fields show that the anisotropy coefficient increases from 1.3 to 1.86 with a mean of 1.71, as the permeability increases from 3 to 770 mD. Generally, the median permeability of the clastic rocks varies from 10 to 100 mD, whereas the anisotropy coefficient fluctuates around 1.5. Thus, there is a numerical sequence in the anisotropy coefficients, which ranges from microanisotropy (from core data) with the median value of $\lambda = 1.5$ to macroanisotropy (from E-log data) with the median value of $\lambda = 3$ for thin-bedded formations and $\lambda = 4.4$ for thick-bedded ones.

11.2.1.3. *Petrophysical relationships*

Experimental and field studies of reservoir-rock properties at reservoir conditions are of great importance. Successful development of oil and gas fields depends largely on the knowledge of such reservoir-rock properties as porosity and permeability. The permeability is one of the most important parameters describing a porous medium, but permeability measurement has some restrictions and requires a rock sample of suitable size and certain geometric shape. The requirement for measuring the other petrophysical properties of rocks, such as porosity, grain-size distribution, pore-size distribution, and specific surface areas, are less restricted. Correlation between the permeability and other easier-to-measure quantities, therefore, have been studied extensively both experimentally and theoretically.

TABLE 11.2

Thickness and permeability used in calculating anisotropy of Balakhany Formation of the Productive Series of Azerbaijan (after Buryakovsky et al., 2001)

Members of Balakhany Formation	Average gross thickness (m)		Non-reservoir rock	Average permeability (mD)		Non-reservoir rock	Permeability (mD)		Anisotropy λ	Variation of anisotropy V_{λ}
	Reservoir rock			Reservoir rock	High		Low	k_{\parallel}		
	High quality	Low quality	High quality	Low quality						
VI	26	69	105	88	5	0.5	141	0.89	3.8	0.34
VII	25	24	60	76	5	0.5	9	0.88	4.6	0.22
VIII	40	57	65	58	5	0.5	17	1.15	3.7	0.30
IX	31	36	95	23	5	0.5	6	0.83	2.6	0.31
X	51	19	64	62	5	0.5	25	1.06	4.8	0.21

If a reservoir is modeled by a bundle of capillary tubes, the rate of flow, q , can be given by the Hagen–Poiseuille equation

$$q = N\pi r_c^4 \Delta p / 8\mu L_c \quad (11.16)$$

where q is the volumetric flow rate (cm³/sec), N is the number of capillaries, r_c is the capillary radius (cm), Δp is the differential pressure across the capillaries (dyn/cm²), μ is the fluid viscosity (P) and L_c is the length of capillaries (cm).

The Darcy equation for rate of flow q is

$$q = kA\Delta p / \mu L_c \quad (11.17)$$

where q is the volumetric rate of flow, k is the permeability (darcy), A is the total cross-sectional area (cm²), Δp is the differential pressure (atm), μ is the fluid viscosity (cP), and L_c is the length of the flow path.

If, instead, viscosity is expressed in poises and differential pressure in dyn/cm², then

$$q = 9.869 \times 10^{-9} k \Delta p / \mu L_c \quad (11.18)$$

The porosity ϕ of this bundle of capillary tubes may be expressed as the capillary volume V_c per unit of bulk volume, V_b :

$$\phi = V_c / V_b = N\pi r_c^2 L_c / AL_c = N\pi r_c^2 / A \quad (11.19)$$

Thus, the total cross-sectional area A of the bundle of capillary tubes is

$$A = N\pi r_c^2 / \phi \quad (11.20)$$

The average capillary tube radius r_c may be found by combining Eqs. 11.16, 11.17, and 11.20:

$$r_c = 2(2k/\phi)^{1/2} \quad (11.21)$$

The surface area per unit of pore volume s_p is given by:

$$s_p = N^2 \pi r_c L_c / N\pi r_c^2 L_c = 2/r_c \quad (11.22)$$

On substituting the value of capillary tube radius from Eq. 11.21 into Eq. 11.22, the specific surface area per unit of pore volume, s_p , can be expressed as

$$s_p = (\phi/2k)^{1/2} \quad (11.23)$$

For the specific surface area per unit of grain volume of rock consisting of equal-size spheres, the following formula was proposed (Buryakovsky et al., 2001):

$$s_g = A/V = N\pi d^2(1 - \phi) / V_{\text{sph}} = 6N\pi d^2(1 - \phi) / Nd^3\pi = 6(1 - \phi)/d \quad (11.24)$$

where A is the surface area, V is the bulk volume of rock, V_{sph} is the total volume of spheres (cm³), N is the number of spheres per unit of grain volume, d is the diameter of sphere (cm), and ϕ is the porosity (fractional).

If spheres (grains) are not equal in size, then the specific surface area per unit of grain volume of such a rock may be calculated using the following formula:

$$s_g = [6(1 - \phi)/100] \sum (C_i/d_i) \quad (11.25)$$

where d_i is the average diameter of grains which constitute an i th grain-size fraction with weight content of C_i in wt%. (Total grain-size distribution is expressed as follows: $C_1 + C_2 + \dots + C_i + \dots + C_n = 100\%$.)

Inasmuch as one of the main influences on the specific surface area is caused by the clay content, C_{cl} , the empirical equation developed for the reservoir rocks is as follows:

$$s_g = 75(1 - \phi)C_{cl} + 532(1 - \phi)(75C_{cl} + 532)(1 - \phi) \quad (11.26)$$

Assuming that $\phi_{ave} = 0.25$, the average correlation between s_g and C_{cl} will be as follows:

$$s_g = 56.3C_{cl} + 400 \quad (11.27)$$

In order to determine the permeability from porosity and specific surface area, one has to solve Eq. 11.23 for permeability

$$k = \phi / (2s_p^2) \quad (11.28)$$

Inasmuch as a porous rock is more complex than a bundle of capillary tubes, a constant K_{cf} is introduced. Thus, the equation for permeability becomes

$$k = \phi / (K_{cf}s_p^2) \quad (11.29)$$

Eq. 11.29 is the familiar Kozeny–Carman equation. Carman (1937, in: Buryakovsky et al., 2001, p. 304) noted that the constant K_{cf} is actually a complex combination of two variables: shape factor for pores, s_{hf} , and tortuosity factor, τ :

$$K_{cf} = (s_{hf})(\tau) \quad (11.30)$$

Tortuosity is equal to the square of the ratio of effective length L_e to the length parallel to the overall direction of flow of pore channels L :

$$\tau = (L_e/L)^2 \quad (11.31)$$

Thus, the Kozeny–Carman constant K_{cf} is a function of both the shape of each particular pore tube and its orientation relative to the overall direction of fluid flow.

Using the multivariable linear regression analysis, Chilingarian et al. (1990) developed an empirical expression for permeability in terms of porosity, specific surface area, and irreducible fluid saturation for carbonate reservoir rocks, with very high (>0.9) coefficient of correlation between porosity and permeability.

This research resolved the age-long controversy whether there is a correlation between porosity and permeability of carbonate rocks or not. By simply introducing two additional variables (specific surface area and irreducible fluid saturation), there is correlation between the porosity and permeability. Microfractures do not contribute much to the porosity ($\phi < 1\%$) but are very permeable.

11.2.2. Statistical approach

In terms of model dimension, the three types of probabilistic-statistical models are defined as follows: (a) one-dimensional, (b) two-dimensional, and (c) multidimensional.

11.2.2.1. One-dimensional models

11.2.2.1.1. Rock properties. The main petrophysical parameters characterizing the properties of rocks are as follows: ϕ — porosity (in %), k — permeability (in mD), C_{cl} — clay content (in wt%), C_{carb} — carbonate cement content (in wt%), relative clay content, $\eta = (1-\phi)C_{cl}/[(1-\phi)C_{cl} + \phi]$, Q_{100} — cation-exchange capacity (in mg-eq. of exchangeable ions per 100 g of rock), and A_{da} — diffusion-adsorption factor in mV.

Almost 4,000 analyses of sands, silts, and shales were made from more than 860 cores obtained from the Productive Series of Azerbaijan and adjacent offshore areas. The cores from Baku Archipelago, South Absheron Offshore Zone, and Lower Kura Depression were tested (Buryakovsky et al., 1986b, 2001). Fig. 11.7 shows the statistical distributions of various rock properties.

The surface activity parameters were determined for different types of rocks. Table 11.3 gives the results of data processing of A_{da} parameter taking into consideration the grain size. This table allows: (1) approximate determination of lithology in studied sections, (2) estimation of an average A_{da} based on lithology, and (3) analysis of A_{da} distribution in all types of rocks. The same types of rocks in the offshore areas have lower A_{da} than in the onshore areas. This difference is largely due to the grain size: sands — approximately 2.1–4.2 times lower; silts — 1.2–1.7 times lower; and argillaceous rocks — 1.1 times lower.

The grain-size characteristics alone, however, do not determine the surface activity parameters. The mineralogy is also of great importance. The rocks of the North Baku Archipelago and South Absheron Offshore Zone are composed of quartz and quartz plus feldspar grains (these rocks belong to the oligomictic¹⁸ and mesomictic classes). The rocks of the Lower Kura Depression belong mainly to polymictic and graywacke classes having a low quartz content, high feldspar content, and different rock fragments (shale, flint, effusive). Fig. 11.8 shows the tendency of Q_{100} and A_{da} parameters to decrease with increasing quartz content. Close to zero A_{da} is predicted in oligomictic rocks with quartz content higher than 75%. By decreasing quartz content to 30–40% and increasing feldspar content to 50–60%, A_{da} increases to 50 mV.

In addition to the grain size and mineralogical composition, the surface activity is greatly influenced by the content and type of clays, which are present mainly as a cementing material in reservoir rocks.

The X-ray analyses of core samples from the Lower Kura Depression in Azerbaijan are correlatable with the surface activity of these rocks. The main clay minerals are

¹⁸Oligomictic rock is a clastic sedimentary rock composed almost of quartz grains (more than 75%); mesomictic is a sedimentary rock with quartz content between 50 and 75%; polymictic is a sedimentary rock composed of many rock types with quartz content not more than 50%.

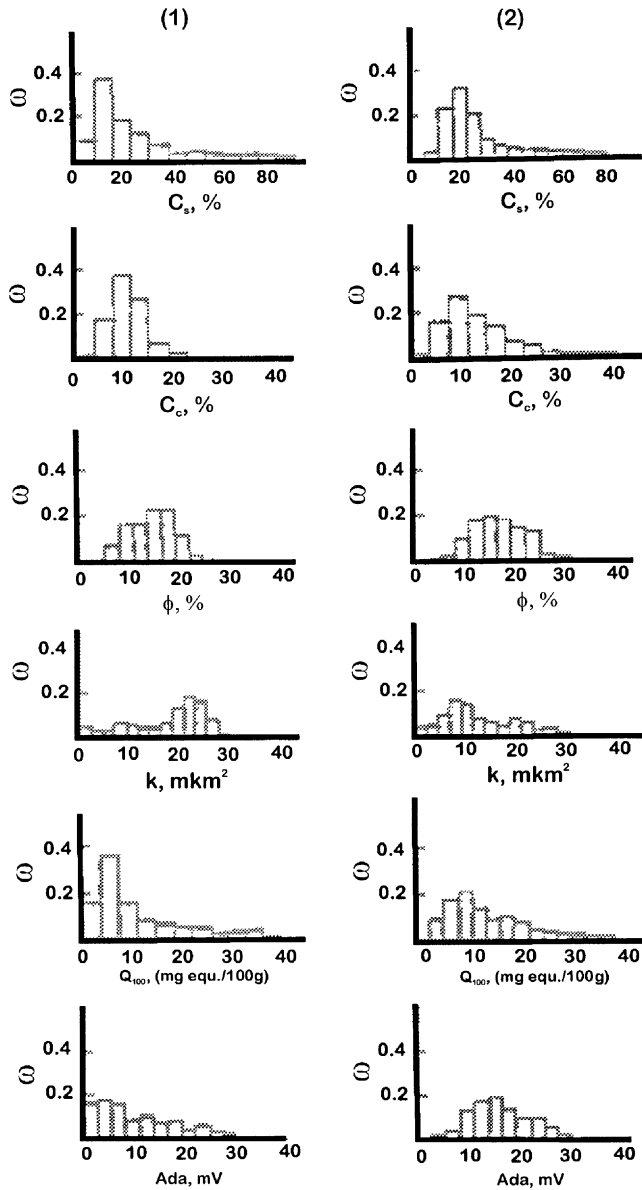

Fig. 11.7. Histograms of the reservoir-rock properties of the Productive Series of Azerbaijan (after Buryakovsky et al., 1986). 1 – Baku Archipelago and South Absheron Offshore Zone, 2 – Lower Kura Depression.

TABLE 11.3

Distribution of A_{da} parameter in the various rocks of Baku Archipelago and Lower Kura Depression in Azerbaijan

Type of rock	Baku Archipelago ($N^a = 159$)							Lower Kura Depression ($N^a = 196$)						
	Frequency (in %) of A_{da} intervals (in mV)						Mean A_{da} (mV)	Frequency (in %) of A_{da} intervals (in mV)						Mean A_{da} (mV)
	0-15	15-30	30-45	45-60	>60	Σ		0-15	15-30	30-45	45-60	>60	Σ	
Coarse sand	3.8	—	—	—	—	3.8	7.5	—	—	—	—	—	—	—
Medium/fine sands	17.6	3.1	—	—	—	20.7	9.7	1.5	8.7	3.1	—	—	13.3	24.2
Sandy loam	5.7	3.8	—	—	—	9.5	13.5	1.5	8.7	5.6	1.0	—	16.8	28.0
Chlidolite	—	—	—	—	—	—	—	1.5	6.1	2.6	1.0	—	11.2	26.6
Sandy silt	11.3	0.6	—	—	—	11.9	8.3	—	1.5	4.6	0.5	—	6.6	35.1
Silt	4.4	11.3	3.2	—	—	18.9	21.5	—	1.5	0.5	0.5	—	2.6	31.5
Clayey silt	0.6	7.6	12.6	0.6	—	21.4	30.9	0.5	8.7	18.4	11.2	0.5	39.4	38.5
Loam	—	0.6	—	—	—	0.6	22.5	—	2.1	1.5	1.5	0.5	5.6	38.8
Sandy-silty shale	—	—	2.5	5.7	1.3	9.5	50.3	—	—	—	3.6	1.0	4.6	55.8
Shale	—	—	—	3.1	0.6	3.7	55.0	—	—	—	—	—	—	—
Overall rocks	43.4	27.0	18.3	9.4	1.9	100	22.4	5.0	37.4	36.3	19.3	2.0	100	33.9

^a N = number of samples.

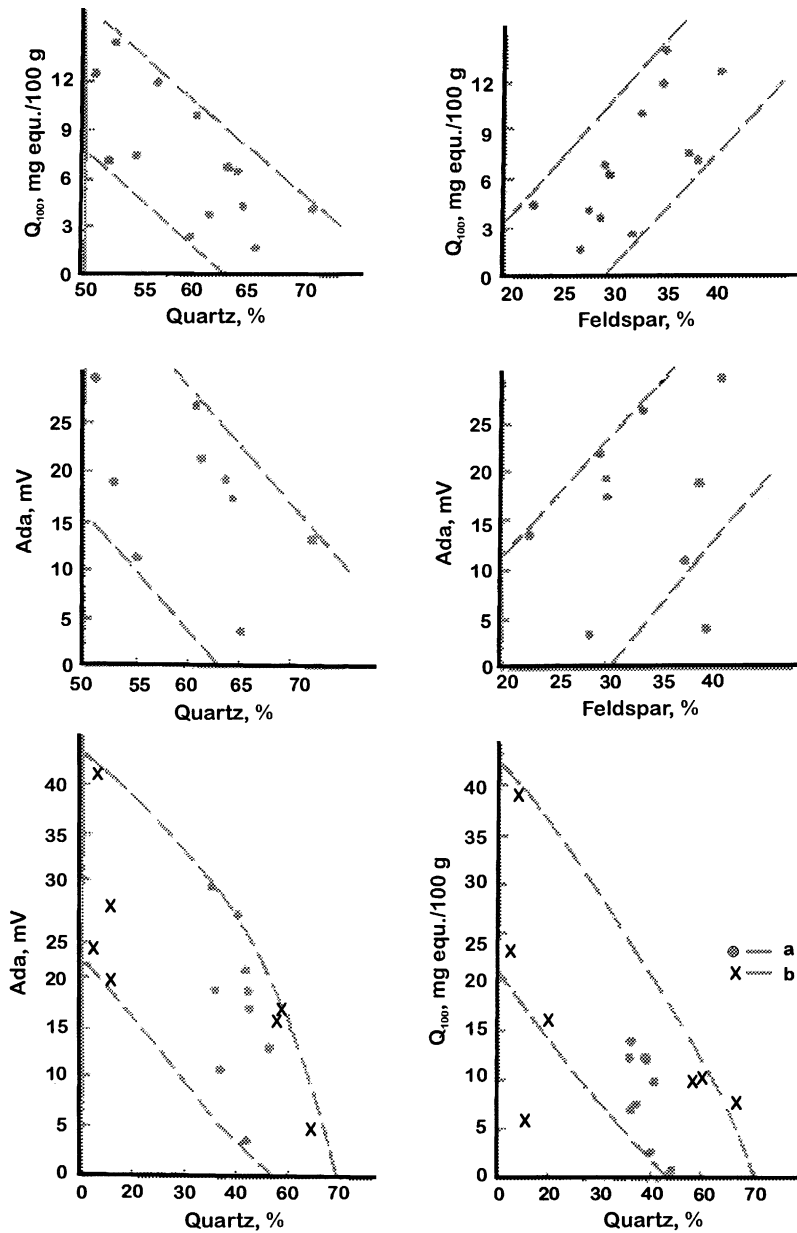

Fig. 11.8. Dependence of surface activity parameters on the mineral composition of rocks in Azerbaijan (after Buryakovskiy et al., 1986). a - Bakhar Field, b - Sangachaly-Duvanny Deniz-Khara Zyrya Field.

montmorillonite (40 to \approx 100 wt%) and illite (0–35 wt%). The content of kaolinite, chlorite, and mixed-layered minerals is approximately equal to 0 to 15–20 wt%. The average content (in wt%) of clays are montmorillonite, 75%; illite, 12%; kaolinite, 5%; chlorite, 4%; and mixed-layered, 4%.

Difference in the content of montmorillonite and other clay minerals in these two regions is quite low, except for clays present in the reservoir rocks. The montmorillonite content in the clay cement of reservoir rocks of the Lower Kura Depression is almost twice higher than in the reservoir rocks of the Baku Archipelago and South Absheron Offshore Zone. This explains why the surface activity of reservoir rocks of the Lower Kura Depression is higher than that in the offshore areas. The A_{da} is practically the same when the montmorillonite content in clays is the same. It is well known that the surface activity of montmorillonite clay is higher in comparison with other clay minerals.

11.2.2.1.2. Crude oil properties. Crude oil is a complex natural system consisting of various components with a considerable predominance of different hydrocarbon groups. Many different classifications of crude oils have been devised. A rational basis of classification is found in some expression of the composition of oils. Composition of oil is determined by separating it into fractions according to the boiling point (molecular weight), followed by establishing the types of hydrocarbons present in each fraction.

To determine the fractional composition of oil, one can use a method of separating it into fractions according to the boiling point (fractional distillation). Fractional composition reflects relative content in percent by weight (wt%) of different oil fractions boiling within definite boiling-point ranges. In Russia, the following main fractions are distinguished: (1) “benzine” fraction with boiling points ranging from 40°C to 200°C, (2) “ligroin” fraction with boiling points ranging from 200°C to 350°C, and (3) residual oil with boiling points ranging from 350°C to 500°C.¹⁹

In order to evaluate the geochemical history, in addition to the fractional oil composition, group-hydrocarbon composition of different fractions is also used, i.e., content of paraffinic, naphthenic, and aromatic groups of hydrocarbons. The group-hydrocarbon composition of crude oil can be clearly presented on a mixture triangle. Based on more than 100 samples of oils from the Absheron Archipelago fields of the South Caspian Basin, the hydrocarbon-group composition of light fractions of crude oil (gasoline and ligroin) was plotted on a triangular diagram in Fig. 11.9. Besides hydrocarbon components, different non-hydrocarbon components are present in the crude oil. Asphaltenes plus resins constitute the major portion of non-hydrocarbon components.

Crude oil density and the contents of asphaltenes plus resins, gasoline, and ligroin of the crude oil from Neft Dashlary oilfield in the Absheron Archipelago are presented as histograms in Fig. 11.10.

¹⁹In USA, the “benzine” fraction as used in Russia, includes light naphtha, gasoline, and heavy naphtha; “ligroin” fraction includes kerosene, stove oil, and light gas oil; and residua includes heavy gas oil, lubricating oil, and vacuum gas oil.

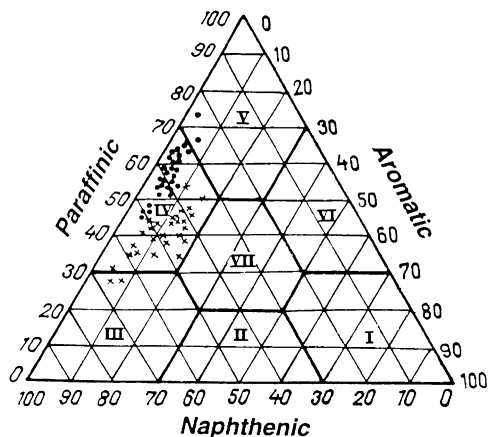

Fig. 11.9. Hydrocarbon-group composition of light fractions of crude oils from the Neft Dashlary Field in Azerbaijan (after Buryakovskiy et al., 2001). • = “benzine” (gasoline); × = “ligroin”.

In the northwestern part of the Absheron Archipelago (Darvin Bank, Pirallaghi Adasi, and Gyurgyany Deniz fields), based on 1,642 analyses, average crude oil parameters (with evaluation of their variation within 2σ limits (95% of confidence)) can be presented as follows:

$$\begin{aligned} \gamma &= 0.9137 \pm 0.0240 \text{ g/cm}^3 & \gamma_{\text{ave}} &= 0.9137 \pm 0.0006 \text{ g/cm}^3 \\ R &= 37.2 \pm 15.1\% & R_{\text{ave}} &= 37.2 \pm 0.37\% \\ B &= 1.54 \pm 1.20\% & B_{\text{ave}} &= 1.54 \pm 0.03\% \\ L &= 7.4 \pm 1.3\% & L_{\text{ave}} &= 7.4 \pm 0.03\% \end{aligned}$$

where γ is the density, R is the content of asphaltenes plus resins, B is the “benzine” (gasoline) content, and L is the content of ligroin.

Based on 820 analyses, in the southeastern part of the Absheron Archipelago (Chalov Adasi, Palchygh Pilpilasi, and Neft Dashlary oilfields) these crude oil parameters are equal to

$$\begin{aligned} \gamma &= 0.8800 \pm 0.0380 \text{ g/cm}^3 & \gamma_{\text{ave}} &= 0.8800 \pm 0.0013 \text{ g/cm}^3 \\ R &= 22.7 \pm 11.8\% & R_{\text{ave}} &= 22.7 \pm 0.41\% \\ B &= 7.4 \pm 7.5\% & B_{\text{ave}} &= 7.4 \pm 0.26\% \\ L &= 9.6 \pm 8.0\% & L_{\text{ave}} &= 9.6 \pm 0.28\% \end{aligned}$$

The crude oil of the northwestern part of the Absheron Archipelago contains more asphaltenes and resins and less low-boiling fractions; hence, its density is higher than that of oil from the southeastern part of archipelago.

Using both numerical characteristics and histograms as they are or as frequency polygons (related frequencies), one can solve different geological and geochemical problems. For example, Fig. 11.11 shows the distribution of oil density in different

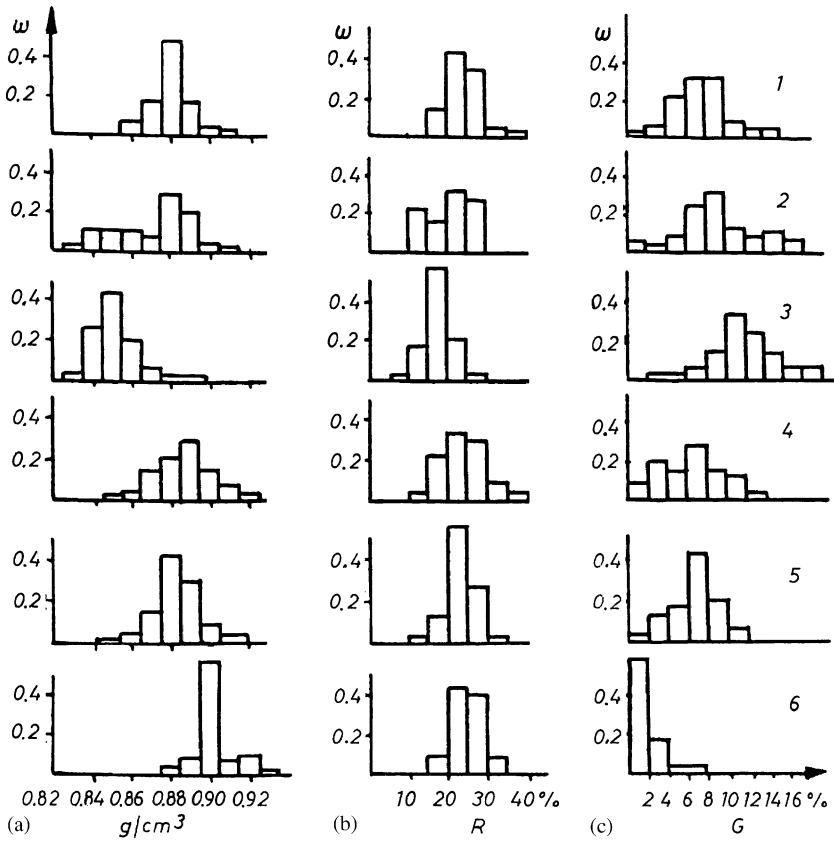

Fig. 11.10. Histograms of crude oil density (a), content of resins plus asphaltenes (b), and “benzine” (gasoline) content (c) in the crude oils of Neft Dashlary Field of Azerbaijan (after Buryakovskiy et al., 2001). Formations (from section top to bottom): 1 – Balakhany, 2 – Fasila, 3 – Nadkirmaku sandy (NKP), 4 – Kirmaku (KS), 5 – Podkirmaku (PK), 6 – Kala (KaS).

formations of the stratigraphic section of Neft Dashlary Field. With increasing stratigraphic depth, the density of crude oil increases. These trends, however, are not present in the upper formations. The increase in the oil density in the upper formations is related to the oxidation of oil by near-surface agents, which increases the content of asphaltenes plus resins and decreases the gasoline content.

11.2.2.2. Two-dimensional models

11.2.2.2.1. Reservoir rocks. Correlations among the reservoir-rock properties in the form of average (orthogonal) regression lines are shown in Figs. 11.12 and 11.13 for two regions of Azerbaijan: (1) Baku Archipelago and South Absheron Offshore Zone and (2) the Lower Kura Depression. The correlation coefficient (r) is presented

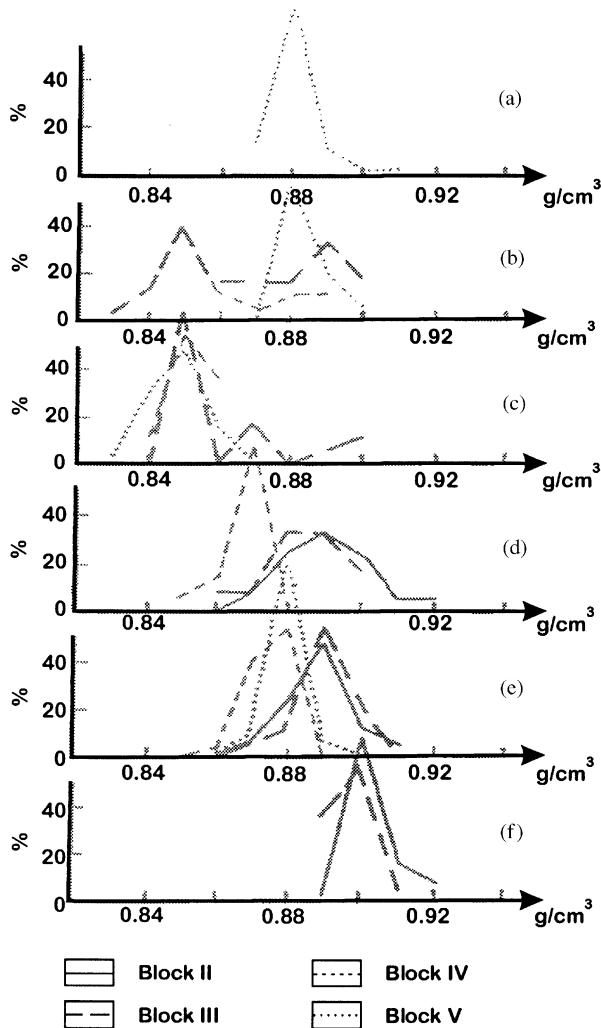

Fig. 11.11. Variation of crude oil density from the top to bottom of the section in the Neft Dashlary Field, Azerbaijan. Formations (from section top to bottom): (a) Balakhany, (b) Fasila, (c) Nadkirmaku sandy (NKP), (d) Kirmaku (KS), (e) Podkirmaku (PK), (f) Kala (KaS). Fault blocks: 1 – II, 2 – IV, 3 – III, 4 – V.

in all cases. The correlation coefficients and criteria of their significance (three times the standard deviation σ_r) are presented in Table 11.4.

From 32 correlations studied, only one differs slightly from zero at a significance level $\alpha = 0.05$ (when $\alpha = 0.01$, this correlation is significant). This correlation is the dependence of permeability on the clay content of the rocks of Lower Kura Depression. All other correlations are reliable enough and have a high statistical

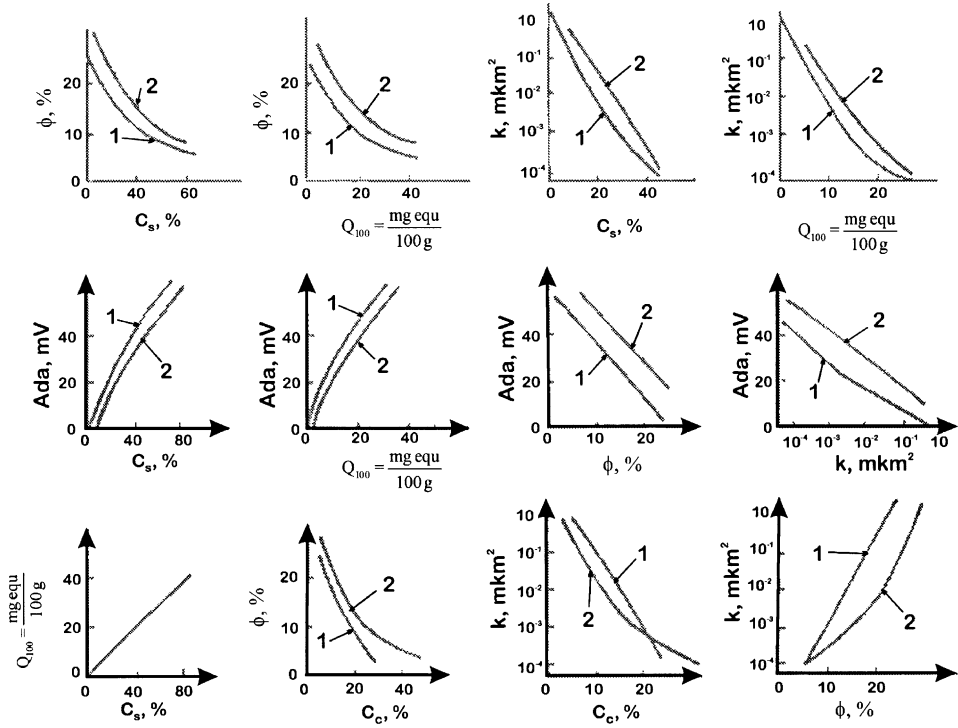

Fig. 11.12. Correlations between properties of the Productive Series reservoir rocks of Azerbaijan (after Buryakovskiy et al., 1986). 1 – Baku Archipelago and South Absheron Offshore Zone, 2 – Lower Kura Depression.

stability, i.e., they are controlled by geological factors. The relationships between the surface activity parameters of rocks and their porosity and clay content (Q_{100} and A_{da} vs. ϕ , C_{sh} and η curves) and their relationships between each other (Q_{100} vs. A_{da} , and ϕ vs. C_{sh} and η) are very useful in petrophysical practice.

Sixteen correlations between variables (reservoir-rock properties and surface activity parameters) are presented in Table 11.5. All these equations can be generalized as the following single model:

$$F_i(y) = a_i + b_i f(x_i) + c_i \psi(x_i) \tag{11.32}$$

where a , b , and c are the empirical coefficients.

Besides these equations, several empirical relationships were developed for the entire Productive Series of Azerbaijan. Relationships between the permeability, k , and clay content, C_{cl} , for various types of rocks are as follows:

Sand and silt : $\lg k = 7.0 - 0.222C_{cl}$

Clayey silt : $\lg k = 7.5 - 0.182C_{cl}$

Chlidolite : $\lg k = 3.8 - 0.200C_{cl}$

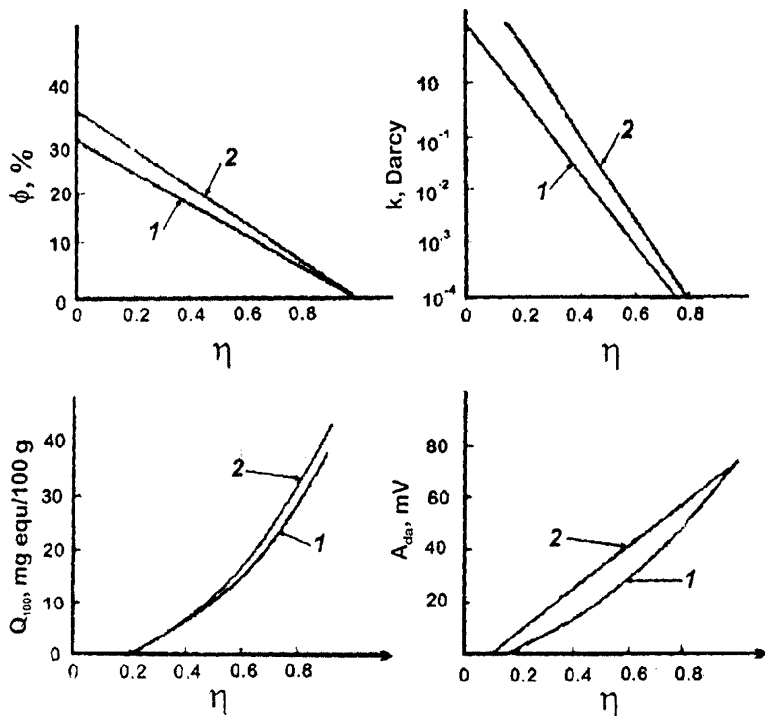

Fig. 11.13. Relationships among the reservoir-rock properties, surface activity parameters, and relative clay content (η) of the Productive Series of Azerbaijan (after Buryakovskiy et al., 1986). 1 – Baku Archipelago and South Absheron Offshore Zone, 2 – Lower Kura Depression.

More sophisticated relationship between the permeability and clay cement content and carbonate cement content was developed as follows:

$$k = (6700 - 130C_{cl}) \exp[-(0.000172C_{cl}^2 - 0.01172C_{cl} - 0.1)C_{carb}] \quad (11.33)$$

where C_{cl} is the clay cement content (in wt%) and C_{carb} the carbonate cement content (in wt%).

Another relationship among the permeability, porosity, clay cement content, and carbonate cement content may be expressed as follows:

$$\lg k = 3.935 + 0.02\phi - 0.075C_{carb} - 0.05C_{cl} \quad (11.34)$$

with a correlation coefficient of multivariable regression of 0.8.

11.2.2.2.2. Crude oil. There are relationships among the crude oil parameters and its composition. These relationships can be studied by correlation and regression

TABLE 11.4

Correlation coefficients between variables and their accuracy

Eq. No.	Correlation between variables	Baku Archipelago and South Apsheron Offshore Zone				Lower Kura Depression			
		<i>N</i>	$ r $	σ_r	$3\sigma_r$	<i>N</i>	$ r $	σ_r	$3\sigma_r$
1	$\phi - C_{carb}$	287	0.192	0.057	0.171	524	0.490	0.033	0.099
2	$k - C_{carb}$	167	0.390	0.060	0.180	254	0.510	0.016	0.140
3	$\phi - C_{cl}$	273	0.473	0.047	0.141	430	0.228	0.046	0.133
4	$k - C_{cl}$	165	0.442	0.063	0.189	198	0.131	0.062	0.186
5	$\phi - \eta_{cl}$	282	0.574	0.040	0.120	532	0.541	0.031	0.093
6	$k - \eta_{cl}$	162	0.555	0.054	0.162	237	0.570	0.044	0.132
7	$k - \phi$	162	0.530	0.057	0.171	252	0.715	0.031	0.093
8	$Q_{100} - C_{cl}$	246	0.610	0.040	0.120	284	0.522	0.043	0.129
9	$A_{da} - C_{cl}$	163	0.718	0.038	0.114	199	0.256	0.066	0.198
10	$Q_{100} - \eta_{cl}$	247	0.626	0.039	0.117	341	0.400	0.045	0.135
11	$A_{da} - \eta_{cl}$	161	0.715	0.039	0.115	252	0.397	0.053	0.159
12	$Q_{100} - \phi$	243	0.433	0.052	0.156	284	0.381	0.051	0.151
13	$A_{da} - \phi$	157	0.631	0.048	0.144	203	0.418	0.058	0.174
14	$Q_{100} - k$	150	0.360	0.071	0.213	151	0.351	0.071	0.213
15	$A_{da} - k$	99	0.576	0.067	0.201	139	0.468	0.066	0.198
16	$Q_{100} - A_{da}$	157	0.670	0.044	0.132	169	0.408	0.064	0.192

Definitions of variables: *N* = number of tests; $|r|$ = absolute value of correlation coefficient; σ_r = standard deviation; ϕ = porosity; *k* = permeability; C_{cl} = clay cement content; C_{carb} = carbonate cement content; η_{cl} = relative clay content ($\eta_{cl} = (1 - \phi)C_{cl}/[(1 - \phi)C_{cl} + \phi]$); Q_{100} = cation-exchange capacity; A_{da} = diffusion-adsorption parameter.

TABLE 11.5

Correlation equations among parameters of reservoir-rock properties in Azerbaijan

Eq. No.	Equation	Eq. No.	Equation
1	$\phi = a_3 - b_3 C_{\text{carb}} + c_3 C_{\text{carb}}^2$	9	$A_{\text{da}} = a_9 + b_9 \sqrt{C_{\text{cl}}}$
2	$\lg k = a_4 - b_4 C_{\text{carb}}$	10	$Q_{100} = a_{14} - b_{14} \eta_{\text{cl}} + c_{14} \eta_{\text{cl}}^2$
3	$\phi = a_1 - b_1 \lg C_{\text{cl}}$	11	$A_{\text{da}} = -a_{15} + b_{15} \eta_{\text{cl}}$
4	$\lg k = a_2 - b_2 C_{\text{cl}}$	12	$\lg Q_{100} = a_{10} - b_{10} \phi$
5	$\phi = a_6 - b_6 \eta_{\text{cl}}$	13	$A_{\text{da}} = a_{11} - b_{11} \phi$
6	$\lg k = a_7 - b_7 \eta_{\text{cl}}$	14	$Q_{100} = a_{12} - b_{12} \lg k$
7	$\lg k = a_5 + b_5 \phi$	15	$A_{\text{da}} = a_{13} - b_{13} \lg k$
8	$Q_{100} = a_8 + b_8 C_{\text{cl}}$	16	$A_{\text{da}} = -a_{16} + b_{16} \sqrt{Q_{100}}$

See Table 11.4 for definitions of variables.

analyses. The correlation analysis shows the presence, strength, and sign of the relationship among the correlated parameters, whereas the regression analysis enables one to establish the type of relationship or to develop models. For example, correlation matrices for different crude oils from offshore oilfields of the Absheron Archipelago in the South Caspian Basin were obtained from correlation analysis. Several types of correlation matrices with different number of analyses and, therefore, with different reliable values of the correlation coefficient, were determined. Table 11.6 is a generalized matrix of correlation coefficients for the oil and gas fields of the Absheron Archipelago. Instead of numerical values of correlation coefficients in this table, only the signs of coefficients with reliable values are presented.

Owing to different relationships, estimation of a certain number of parameters of a given crude oil may be sufficient to make a conclusion about values of other parameters. The simplest and at the same time one of the main properties of crude oil is its density, which is closely dependent on the fractional composition and the content of asphaltenes and resins in the crude oil. Relationships among the major crude oil parameters is of great interest from the point of view of petroleum geochemistry, and equations derived by regression analysis can serve as mathematical models of the crude oils.

The influence of these components of crude oil on density can be studied by means of correlation for four parameters: (1) γ = oil density (in g/cm^3), (2) R = content of resins plus asphaltenes (in wt%), (3) B = content of gasoline (in wt%), and (4) L = content of ligroin (in wt%). Based on 820 analyses, the correlation between the oil density and content of resins plus asphaltenes was tabulated (Table 11.7) as an example. Empirical equation of relationship (see Fig. 11.14) between the density and content of resins plus asphaltenes in the crude oil in the form of regression R on γ is as follows:

$$\gamma = 0.826 + 0.00237R \quad (11.35)$$

TABLE 11.6

Signs of correlation coefficients among the crude oil parameters (generalized matrix), offshore oilfields of Absheron Archipelago in Azerbaijan

Parameters	Coking ability	Acidity	Viscosity	Content of resins and asphaltenes	Trace elements												
					V	Fe	Ni	Cr	Ti	Co	Mo	Be	Sr	Sn	V/Ni		
Density	+	+	+	+	+		+				+						
Coking ability		+	+	+	+		+				+	+					+
Acidity			+	+	+							+					+
Viscosity				+	+						+						+
Content of resins and asphaltenes					+		+				+	+					
<i>Trace elements</i>																	
V							+	+	+		+	+					
Fe								+									+
Ni												+		+			
Cr																	
Ti																	+
Co													+				

TABLE 11.7

Correlation between the crude oil density and content of resins plus asphaltenes (after Buryakovsky and Dzhevanshir, 1992)

Density (g/cm ³)		Content of resins plus asphaltenes (wt%)									N_γ
range $\Delta\gamma$	average γ_{ave}	5-10	10-15	15-20	20-25	25-30	30-35	35-40	40-45	45-50	
		7.5	12.5	17.5	22.5	27.5	32.5	37.5	42.5	47.5	
0.815-0.825	0.82	2									2
0.825-0.835	0.83	3	3	3							9
0.835-0.845	0.84	1	10	20	4						35
0.845-0.855	0.85	3	20	35	8						66
0.855-0.865	0.86		16	24	11	2					53
0.865-0.875	0.87		4	32	47	11					94
0.875-0.885	0.88		3	32	130	56	3	3			227
0.885-0.895	0.89		3	13	95	63	3				177
0.895-0.905	0.90			2	39	43	6	2			92
0.905-0.915	0.91			1	7	10	8	7	2	1	36
0.915-0.925	0.92					4	8	4	1	1	18
0.925-0.935	0.93					1	3	1	1	2	8
0.935-0.945	0.94					1	1	1			3
N_R		9	59	162	341	191	32	18	4	4	820

N_γ = number of crude oil density determinations; N_R = number of determinations of resins plus asphaltenes content.

or in the form of regression γ on R :

$$R = 212(\gamma - 0.778) \quad (11.36)$$

The correlation coefficient between the R and γ is 0.710.

Using the technique proposed by Buryakovsky et al. (1974), the equation of orthogonal regression can be written in the following form:

$$R = 295(\gamma - 0.805), \quad \gamma = 0.0034R + 0.805 \quad (11.37)$$

Both equations are equivalent. Conjugated equations of regression represent the conjugated axes of the correlation ellipse.

According to the equations of orthogonal regression developed for Azerbaijan crude oils, the crude oil having density of 0.805 g/cm³ does not contain resins and asphaltenes. It is noteworthy that the value of 0.802 g/cm³ corresponds approximately to the density of ligroin obtained by refining crude oil from fields of the Absheron oil and gas region of Azerbaijan. If the content of resins and asphaltenes varies from 57% to 87%, the density reaches 1.0-1.1 g/cm³, i.e., crude oil is changing into asphalt.

Conjugated and orthogonal lines of regression, the equations of which were given earlier, are presented in Fig. 11.14a. Lines of equal probability of the pairs γ and R are drawn in accordance with the correlation table (see Table 11.7). As shown, the form and the tightness of the contour lines along the main axis may also show a

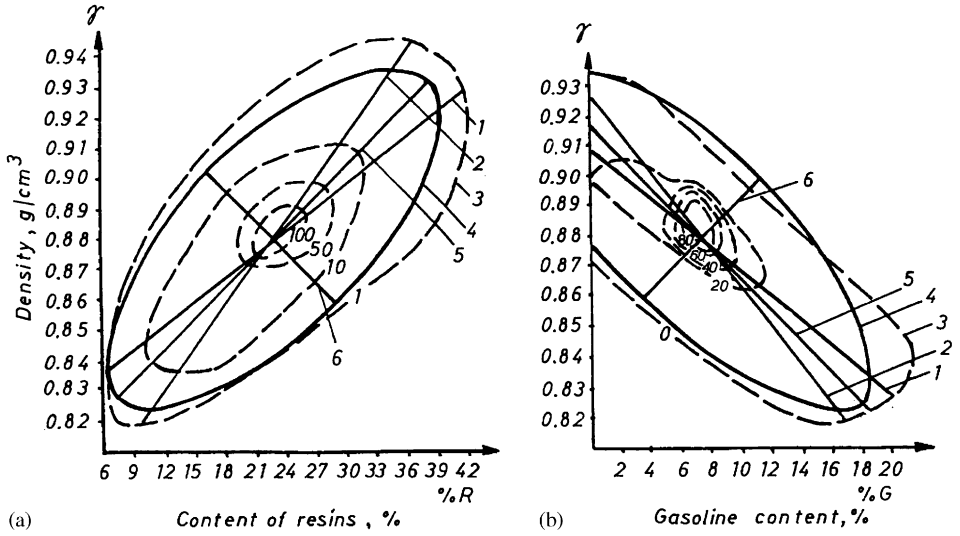

Fig. 11.14. Orthogonal and conjugated regression lines for relationships in crude oils from Neft Dashlary Field, offshore Azerbaijan (after Buryakovsky and Dzhevanshir, 1992). (a) Oil density (g/cm^3) versus content of resins (R , %); (b) oil density versus “benzine” (gasoline) content (B , %). 1 – Regression of γ on R and B ; 2 – regression of R or B on γ ; 3 – equal-frequency curve; 4 – ellipse of correlation; 5 – major axis of the ellipse (line of orthogonal regression); 6 – minor axis of the ellipse.

sufficiently close relation between the density and content of resins plus asphaltenes in crude oil. Variations in the parameters were as follows: $v_R = 26.0\%$ and $v_\gamma = 2.2\%$ for R and γ , respectively. This shows that the content of resins plus asphaltenes varies more than density.

The crude oil density is greatly affected by the content of low-boiling components. With increasing content of gasoline and ligroin, the density of oil decreases. Based on 792 analyses of crude oil, equations for the relationship between the oil density and gasoline content were determined as follows:

$$\gamma = 0.9063 - 0.00380B \tag{11.38}$$

and

$$B = 143.7 - 155\gamma \tag{11.39}$$

The equations of the line of orthogonal regression (the main axis of the correlation ellipse) were presented as follows:

$$\gamma = 0.915 - 0.0500B, \quad B = 200(0.915 - \gamma) \tag{11.40}$$

The correlation coefficient of -0.760 indicated a sufficiently close, reverse, linear relation between γ and B . At $\gamma = 0.915 \text{ g}/\text{cm}^3$, crude oil no longer contains gasoline fraction. The coefficient of variation for distribution of gasoline content was 51.4% , whereas for density it was 2.2% . Lines of equal probability form concentrically situated ovals stretched along the main axis (Fig. 11.14b). Calculated values of

TABLE 11.8

Correlation coefficients of paired relationships between Azerbaijan crude oil parameters (after Buryakovsky and Dzhevanshir, 1992)

Relationship between	Correlation coefficient
γ and R	+0.71
γ and B	-0.76
γ and L	-0.47
B and R	-0.60
L and R	-0.12
L and B	+0.64
γ and R, B, L	0.83

correlation coefficients for all paired relationships between crude oil parameters are presented in Table 11.8.

11.2.2.2.3. Natural gas. The natural gas accumulated in gas, gas-condensate, and gas-oil fields is a multicomponent system, which consists of saturated hydrocarbons: methane, CH_4 ; followed by ethane, C_2H_6 ; propane, C_3H_8 ; butanes, C_4H_{10} ; and heavier components such as pentanes, C_5H_{12} ; hexanes, C_6H_{14} ; and higher. These compounds have the chemical formula of $\text{C}_n\text{H}_{2n+2}$. Natural gas is partially or completely saturated with water vapor and may contain nitrogen, N_2 ; inert (rare) gases such as helium, He, and argon, Ar; acid gases such as carbon dioxide, CO_2 , and hydrogen sulfide, H_2S ; and sometimes mercury, Hg.

The natural gas that occurs along with crude oil may be in either free or dissolved state. The writers arbitrary define natural gas as free if, when it produced at a rate higher than $10,000 \text{ m}^3/\text{day}$, the ratio of gas volume to liquid (oil) volume is greater than 1,000. Associated (dissolved) gas is characterized by gas/oil ratio (GOR) below 1,000.

For the natural gas associated with crude oil, linear empirical relationships have been developed by Buryakovsky (1974) between the density and the contents (% by vol.) of methane (CH_4) and carbon dioxide (CO_2) (Fig. 11.15):

$$\gamma = (155.3 - \text{CH}_4)/100 \quad (11.41)$$

and

$$\gamma = (0.918\text{CO}_2 + 60)/100 \quad (11.42)$$

Using the CH_4 and CO_2 contents of gas (% by vol.), the content of C_2^+ hydrocarbons (ethane and heavier) can be found according to the following formula:

$$\text{C}_2^+ = 100 - (\text{CH}_4 + \text{CO}_2) \quad (11.43)$$

The content of heavier hydrocarbons (C_5^+) (in g/m^3) can be calculated from the volume percents of C_2^+ using the following formula:

$$\text{C}_5^+ = 40\text{C}_2^+ \quad (11.44)$$

The above formulae may be useful for classification of gases associated with crude oil.

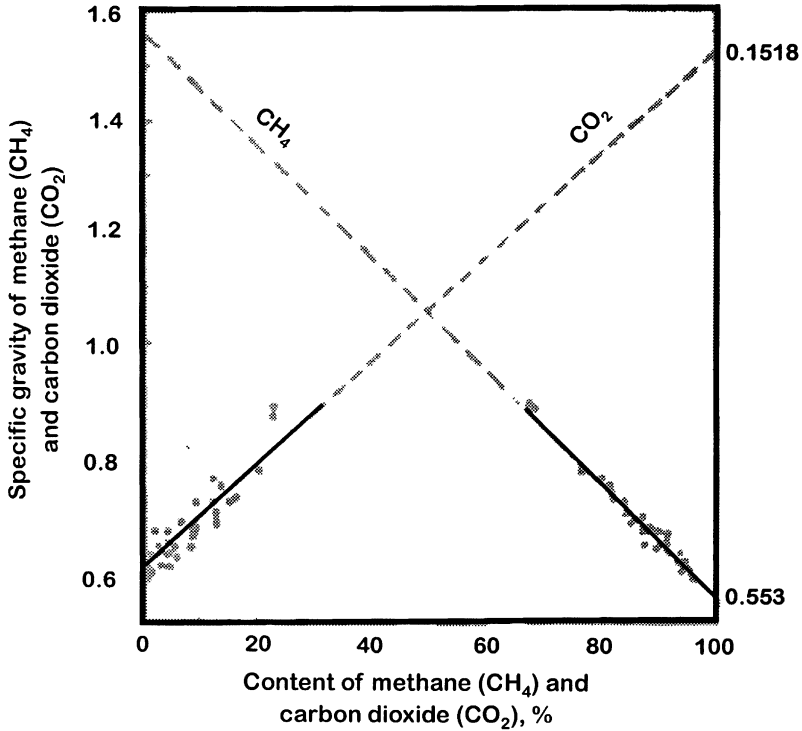

Fig. 11.15. Relationships between the specific gravity of gas (compared to air) and the contents of CH₄ and CO₂.

11.2.2.2.4. *Formation water.* The total salinity of formation waters and their composition depend on a number of subsurface processes, which are controlled by various natural factors. Because of different processes of formation and evolution of salt content, subsurface waters in different oil and gas fields significantly differ in their characteristics. That is why, the preparation of reliable formation water classifications for the formation water identification (and clarification of its origin and subsequent evolution) is of great importance. In spite of significant variation in the salt composition, it is possible to classify formation waters using an approach based on mathematical simulation.

The main component of formation water in most oilfields is sodium chloride. Thus, water salinity depends mainly on the content of chlorine anions or sodium cations. Relationship between the content of chlorine rCl^- or sodium rNa^+ ions and water salinity $\sum r$ can be described as a linear function

$$\begin{aligned} \sum r &= a_1 rCl^- + a_2 \\ \sum r &= b_1 rNa^+ + b_2 \end{aligned} \tag{11.45}$$

where r is ion amount (in mg-eq.); and a_1 , a_2 , b_1 , and b_2 are empirical coefficients determined from data of formation water composition.

For example, formation water of the Pliocene productive formations of the Absheron Archipelago oilfields in the South Caspian Basin are characterized by empirical coefficients shown in the following table:

Field	a_1	a_2	b_1	b_2
Darvin Bank	2.40	20	2	10
Pirallaghi Adasi	1.72	26	2	3
Chalov Adasi	1.72	25	2	2
Palchygh Pilpilasi	1.60	22	2	0
Neft Dashlary	1.92	18	2	5

Based on the data on formation waters in the onshore oilfields of Azerbaijan (Zhabrev and Khatskevich, 1950, in: Samedov and Buryakovsky, 1966, p. 136), these coefficients were as follows: $a_1 = 1.96$, $a_2 = 6$, $b_1 = 2$, and $b_2 = 0$.

Data obtained by Eremenko and Bezhayev (1956, in: Samedov and Buryakovsky, 1966, p. 137) from oilfields of Daghestan area (Southeastern Pre-Caucasus oil and gas province) indicate that these coefficients are different in different oilfields and stratigraphic sequences. For the Tertiary and Cretaceous formations, the following values were obtained: $a_1 = 1.8$, $a_2 = 11.5$, $b_1 = 2$, $b_2 = 0.5$ and $a_1 = 2$, $a_2 = 1-3$, $b_1 = 2$, and $b_2 = 15$, respectively.

Type of formation water can be determined by $r\text{Na}^+/\text{rCl}^-$ ratio: water is alkaline if $r\text{Na}^+/\text{rCl}^- > 1$ and is hard if $r\text{Na}^+/\text{rCl}^- < 1$.

Considering the system of Eqs. 11.45, one can obtain the following equation:

$$r\text{Na}^+/\text{rCl}^- = a_1/b_1 \left[\left(\sum r - b_2 \right) / \left(\sum r - a_2 \right) \right] \quad (11.46)$$

For the Neft Dashlary Oilfield in the Absheron Archipelago (Azerbaijan), Eq. 11.46 can be presented as follows:

$$r\text{Na}^+/\text{rCl}^- = 0.96 \left[\left(\sum r - 5 \right) / \left(\sum r - 18 \right) \right] \quad (11.47)$$

Transition from the alkaline to hard water occurs at $r\text{Na}^+ = r\text{Cl}^-$. Water salinity at this transition point can be determined from Eq. 11.46 at $r\text{Na}^+ = r\text{Cl}^-$:

$$\sum r = (a_1 b_2 - b_1 a_2) / (a_1 - b_1) = m/n \quad (11.48)$$

where $m = (a_1 b_2 - b_1 a_2)$ and $n = (a_1 - b_1)$.

For example, in the stratigraphic section of Neft Dashlary Oilfield this transition occurs at a water salinity of $\sum r = 330$ mg-eq./100 g of brine. The transition point may be found as the abscissa of intersection of two straight lines described by Eqs. 11.45.

Class of formation water is determined using characteristics proposed by Charles Palmer in 1911 (see Sulin, 1948) based on the correlation between $(\text{Na}^+ + \text{K}^+)$ and $(\text{Cl}^- + \text{SO}_4^{2-} + \text{NO}_3^-)$ ions (in % mg-eq.). The ion-equivalent form (mg-eq.) converted

from generally used forms (ppm or mg/l, ppk or g/l) expresses ion combination in equivalent quantities, depending on their ionic mass and valence. This conversion is performed by dividing the amount of ion by the equivalent mass of the ion. The sum of the cations in mg-eq. must be equal to the sum of anions in mg-eq. The sums of the anions and cations are equated 50% each and their total sum is equal 100%. Palmer proposed to determine the following six characteristics of the subsurface waters:

- (1) First salinity S_1 includes $\text{Na}^+ + \text{K}^+$ salts of strong acids.
- (2) Second salinity S_2 includes $\text{Ca}^{2+} + \text{Mg}^{2+}$ salts of strong acids.
- (3) Third salinity S_3 includes Fe salts of strong acids.
- (4) First alkalinity A_1 includes $\text{Na}^+ + \text{K}^+$ salts of weak acids.
- (5) Second alkalinity A_2 includes $\text{Ca}^{2+} + \text{Mg}^{2+}$ salts of weak acids.
- (6) Third alkalinity A_3 includes salts of Fe and H^+ in combination with weak acids.

The first salinity may be determined from the following formulae:

$$\text{for alkali water : } S_1 = 200/a_1 \left(1 - a_2 / \sum r\right) \quad (11.49)$$

$$\text{for hard water : } S_1 = 200/b_1 \left(1 - b_2 / \sum r\right) \quad (11.50)$$

For the Neft Dashlary formation waters, which belong to the sodium bicarbonate type, Eq. 11.49 becomes:

$$S_1 = 105 - 1900 / \sum r \quad (11.51)$$

where the S_1 ranges from 45% to 97%.

The value of the first alkalinity A_1 is determined as the doubled value of difference between content of strong acids and content of alkali metals. Combining Eqs. 11.49 and 11.50 one can obtain:

$$A_1 = 200/a_1 b_1 \left[a_1 - b_1 - (a_1 b_2 - b_1 a_2) / \sum r \right] = 200/a_1 b_1 \left(n - m / \sum r \right) \quad (11.52)$$

For the Neft Dashlary Formation waters this equation is:

$$A_1 = 1370 / \sum r - 4.2 \quad (11.53)$$

where the variation in A_1 value is 2–55%. $A_1 = 0$ at $\sum r = 330$ mg-eq.

The value of second alkalinity A_2 is determined as the difference between 100% and the sum of ($S_1 + A_1$) for alkali waters and the sum of ($S_1 + S_2$) for hard waters. Corresponding equations are as follows:

$$\text{for alkali water : } A_2 = 100 \left[1 - 2/b_1 \left(1 - b_2 / \sum r \right) \right] \quad (11.54)$$

$$\text{for hard water : } A_2 = 100 \left[1 - 2/a_1 \left(1 - a_2 / \sum r \right) \right] \quad (11.55)$$

For the Neft Dashlary formation waters this equation becomes:

$$A_2 = 530 / \sum r - 0.8 \quad (11.56)$$

where the variation in A_2 value is 1–12%.

The first and second alkalinity exhibit simple correlation with the various components of brine. The first alkalinity depends on the content of SO_4^{2-} ion as follows:

$$A_1 = c - dr\text{SO}_4^{2-} \quad (11.57)$$

where $c = 30$ and $d = 50$ for Neft Dashlary Formation waters.

The second alkalinity depends on the content of Ca^{2+} and Mg^{2+} ions:

$$A_2 = er(\text{Ca}^{2+} + \text{Mg}^{2+}) \quad (11.58)$$

where $e = 0.375$ for Neft Dashlary Formation waters.

There is also relationship between A_2 and HCO_3^- content:

$$A_2 = fr\text{HCO}_3^- \quad (11.59)$$

where $f = 0.085$ for formation waters in Daghestan Mesozoic rocks, Eastern Pre-Caucasus (Russia).

Relationships between the first alkalinity or second salinity and $r\text{Na}^+/r\text{Cl}^-$ ratio is very useful. These relationships, however, are non-linear. A more convenient correlation is the linear correlation between A_1 or S_2 and $r\text{Cl}^-/r\text{Na}^+$ ratio:

$$A_1 = g(1 - r\text{Cl}^-/r\text{Na}^+) \quad (11.60)$$

$$S_2 = g(r\text{Cl}^-/r\text{Na}^+ - 1) \quad (11.61)$$

where $g = 95$.

Established analytical and statistical relationships may be expanded in the case when besides chlorides the formation water also includes sulfates and other salts of strong acids. In this case, $r(\text{Cl}^- + \text{SO}_4^{2-} + \text{NO}_3^-)$ should be substituted for $r\text{Cl}^-$ in the system of Equations 11.45.

The above analytical relationships may be useful for solving various problems involving formation water hydrochemistry. They also allow inference on the various formation water characteristics even in the case of the incomplete chemical analysis. Similarly, the type of formation water and its characteristic coefficients may be determined from the data on water salinity only. In this case, for example, numerical values of Palmer's characteristics may be found from the total water salinity (Fig. 11.16).

11.2.2.3. Multidimensional models

11.2.2.3.1. Reservoir rocks. Within the Absheron Peninsula and the adjacent South Caspian offshore areas, clastic rocks of Productive Series are composed mainly of quartz, feldspar, and various rock fragments. The distribution of rock types in each formation reflects the cyclic nature of the section. The section is composed of sandstones, siltstones, shales, unsorted sediments, and evaporites.

The mineral composition of the Middle Pliocene rocks of the South Caspian Basin is characterized by several different associations of light and heavy minerals. Minerals of the light group include quartz, feldspar, and various rock fragments. Five heavy mineral groups were identified: (1) ore minerals (pyrite, magnetite, limonite, leucoxene), (2) stable minerals (garnet, zircon, tourmaline, rutile), (3) kyanite or

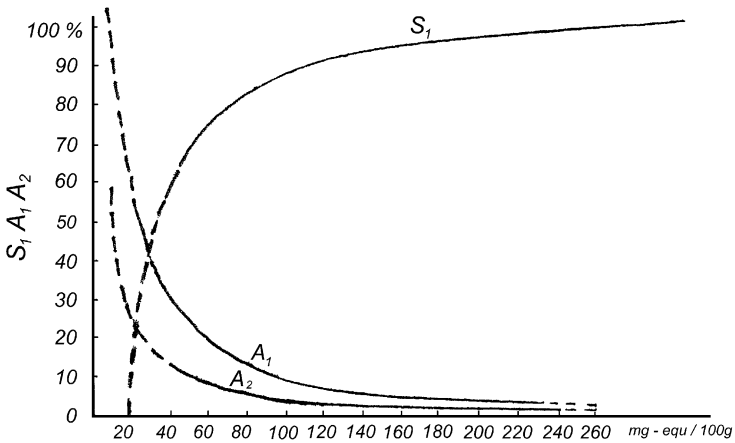

Fig. 11.16. Dependencies between Palmer's characteristics and water salinity.

disthene (disthene, staurolite, sillimanite), (4) micas (muscovite, biotite, chlorite), and (5) glauconite. The distributions (contents) of these mineral groups in rocks are presented in Fig. 11.17.

The triangular diagrams (see Fig. 11.18) show the rock composition (Productive Series of the South Caspian Basin) with respect to quartz (*Q*), feldspar (*FS*), and rock fragments (*RF*). Fig. 11.18 also shows the contour lines of equal concentration of heavy minerals with respect to the overall mineral composition of host rocks. The content of stable minerals generally ranges from 1% to 8% (the relative frequency of this range is 63%). Content less than 1% is observed in 8% of the cases and more than 8% in 28% of the cases. The content of stable minerals decreases from 10% for rocks composed mostly of quartz to 4% for lithite. (Lithite is a rock composed of sand-size rock fragments.) The kyanite group of minerals is absent in 68% of the rocks studied. Their content is at a maximum in monomineralic quartz sandstones (3.8%) and a minimum in lithite (0.2%). The relationship of reservoir-rock properties (clay content, porosity, and permeability) to mineral composition of rocks is shown in Fig. 11.19. Petrographic and mineralogic multivariable composition and reservoir-rock properties of terrigenous (siliciclastic) rocks discussed here are presented in Table 11.9.

11.2.2.3.2. Crude oil. When data on correlation coefficients for all paired relationships or equations (see Table 11.8) are available, one can derive an equation of multiple regression containing all three independent variables (resins plus asphaltenes content *R*, gasoline content *B*, and ligroin content *L*). The equation of multiple regression is a linear function

$$\gamma = \gamma_0 + aR + bB + cL \tag{11.62}$$

where γ is the density of crude oil, γ_0 is the density of crude oil when $R = B = L = 0$, and a , b , and c are empirical coefficients.

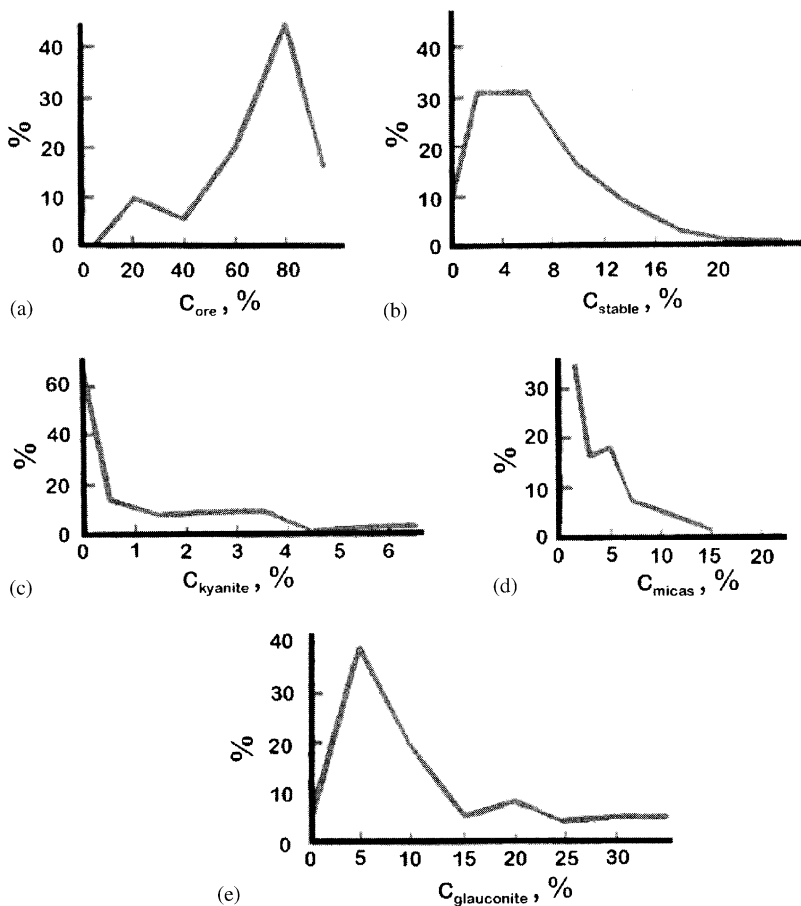

Fig. 11.17. Statistical distribution of heavy-mineral content (%): (a) ore minerals, (b) stable minerals, (c) kyanite/disthene group, (d) micas, (e) glauconite.

The general equation relating γ , R , B , and L is as follows:

$$\gamma = 0.864 + 0.0021R - 0.0023B - 0.0014L \quad (11.63)$$

As shown in Table 11.8, the coefficient of multiple correlation is higher than any paired correlation coefficient. Thus, the equation of multiple correlation, which takes into consideration the influence of every parameter, describes the experimental relationships more reliably than the paired equations of regression. In deriving this regression, some parameters were fixed at average levels.

To expedite the calculations, a nomogram (Fig. 11.20) was constructed according to Eq. 11.63. For example, at given values of $R = 23\%$, $B = 7.2\%$, and $L = 7.0\%$, the density of crude oil $\gamma = 0.882 \text{ g/cm}^3$.

Inasmuch as the dependence of density on variations in ligroin content in the crude oil is weak, the term in the equation of multiple relationship corresponding to

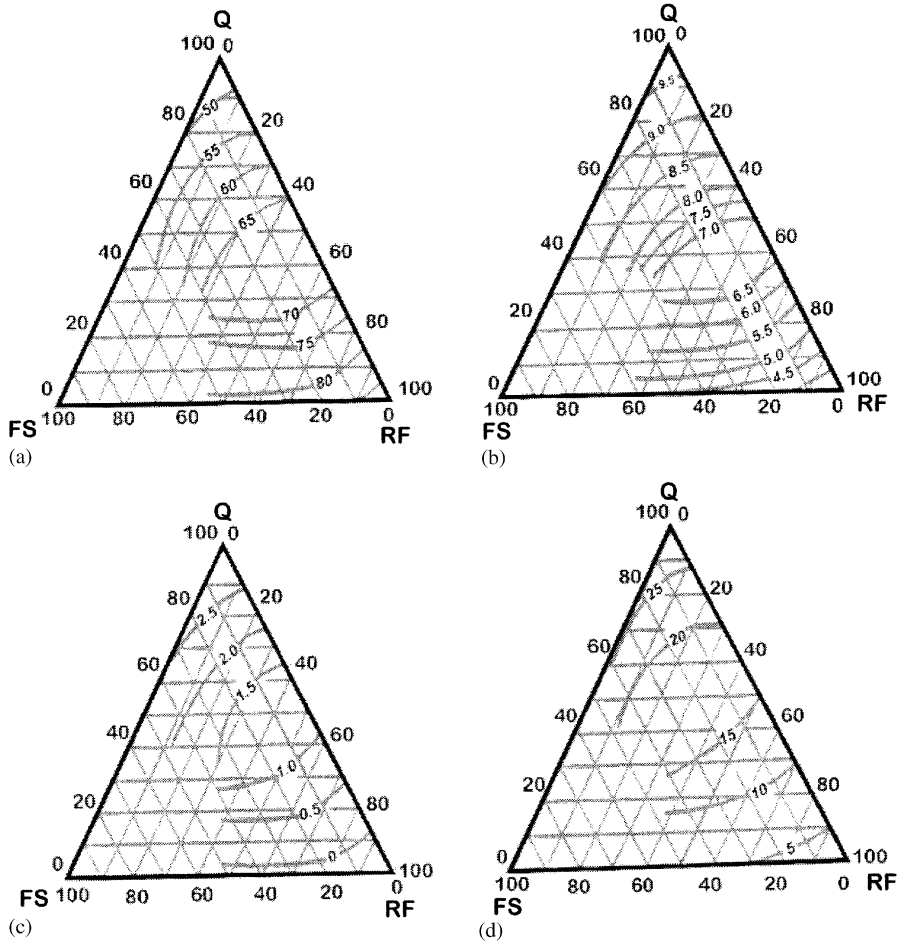

Fig. 11.18. Variation in heavy-mineral content (solid lines) depending on the contents of rock-forming minerals (Q – quartz, FS – feldspar, RF – rock fragments). (a) Ore minerals, (b) stable minerals, (c) kaynite/disthene group, (d) micas.

the influence of ligroin on density may be replaced by a constant value. In this case, the equation can be written as follows:

$$\gamma = 0.8707 + 0.0013R - 0.0027B \tag{11.64}$$

The coefficient of multiple correlation is 0.830. Graphically this relationship is presented in Fig. 11.21. As shown, the dependence of crude oil density on the content of resins plus asphaltenes and gasoline, with ligroin influence being excluded, is clearly expressed graphically and can be used in calculations.

Relationship among the viscosity, density, and temperature of crude oil (changing simultaneously) has also been studied. In the Absheron oil and gas region depth of burial of productive reservoirs varies from 500 to 3500m, whereas the reservoir

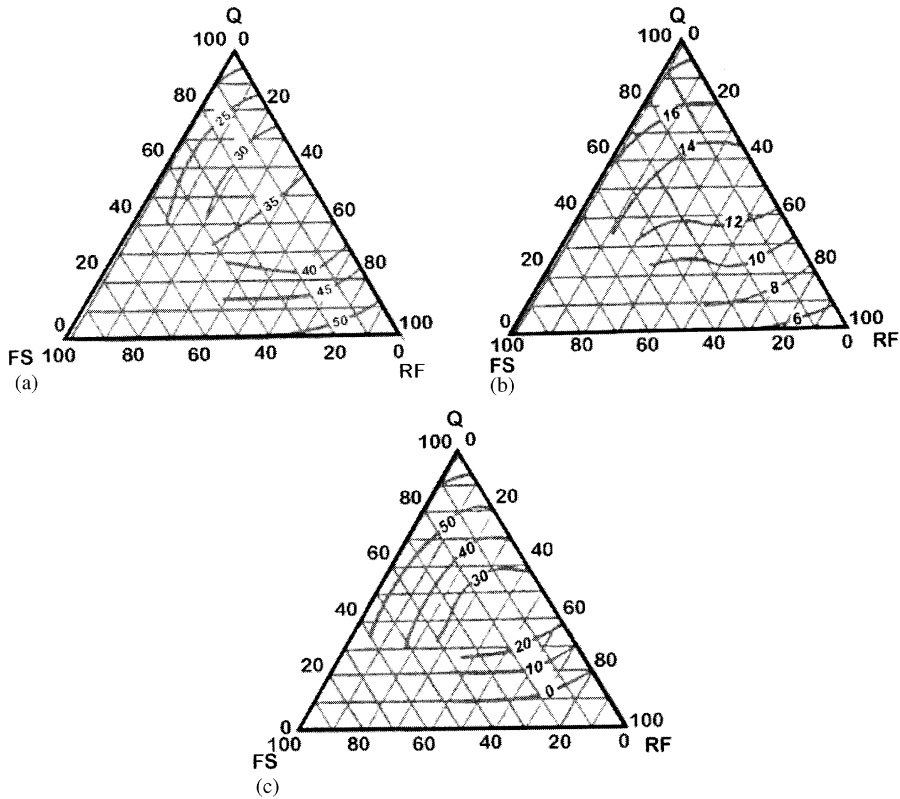

Fig. 11.19. Variation in reservoir-rock properties (solid lines) depending on the contents of rock-forming minerals (Q – quartz, FS – feldspar, RF – rock fragments). (a) Clay content, (b) porosity, (c) permeability.

temperature ranges from 30°C to 90°C . Due to influence of various factors, density of crude oils varies from 0.83 to 0.93 g/cm^3 (Buryakovsky and Dzhevanshir, 1992).

Dynamic viscosity μ (in cP and kinematic viscosity ν (in cst) are related as follows:

$$\nu = \mu/\gamma \quad (11.65)$$

where γ is the specific gravity of liquid.

Table 11.10, which is based on 580 analyses, shows the dependence of crude oil viscosity on density at five different temperatures: 10°C , 20°C , 30°C , 40°C , and 50°C . Fig. 11.22 shows the dependence of viscosity on temperature. Logarithmic scale was used for viscosity, transforming asymmetric empiric distribution into symmetric one, close to the normal law. This figure shows that viscosity and temperature are related by logarithmic or power law.

Relationship among kinematic viscosity, density, and temperature is presented in Fig. 11.23. This relationship is best described by an exponential function

$$\nu = \nu_0 \exp(-bT) \quad (11.66)$$

TABLE 11.9

Classification of terrigenous (siliciclastic) rocks of Azerbaijan based on mineralogic composition and reservoir parameters

Type of rock	Content of light minerals (%)			Content of heavy minerals (%)						Reservoir properties		
	Quartz	Feldspar	Rock fragments	Ore group	Stable group	Kyanite group	Micas	Glauconite	Other	Clay content (%)	Porosity (%)	Permeability (mD)
<i>Absheron Peninsula and Archipelago</i>												
Monomineralic	90–100	0–10	0–10	45–49	12–14	4.0–5.5	4.5	23–26	1–12	10–14	23–26	500–1000
Oligomictic	75–90	0–25	0–25	45–53	10–12	3.0–4.0	6.4	20–23	2–16	14–20	20–23	200–500
Polymictic	50–75	0–50	0–50	50–57	8–10	2.0–3.0	6.2	14–19	5–20	20–26	16–20	100–200
Graywacke	0–50	0–75	0–75	57–65	6–8	1.0–2.0	6.0	6–14	5–24	26–32	13–16	50–100
Lithite	0–25	0–25	75–100	65–72	4–6	0.5–1.0	5.8	2–6	9–23	32–40	10–13	10–50
Arkose	0–25	75–100	0–25	55–62	6–8	1.0–2.0	6.0	10–14	8–22	24–30	13–15	20–50
<i>Baku Archipelago</i>												
Monomineralic	90–100	0–10	0–10	49–53	9.5–10	2.7–3.8	2.4	25–28	5–12	18–22	18–20	60–70
Oligomictic	75–90	0–25	0–25	51–68	8.7–9.5	2.2–2.7	4.4	22–25	4–14	22–28	15–18	45–60
Polymictic	50–75	0–50	0–50	54–67	7.5–8.7	1.5–2.2	4.3	15–21	0–17	28–34	13–15	30–45
Graywacke	0–50	0–75	0–75	65–75	5.0–7.5	0.5–1.5	4.1	6–15	0–21	34–43	8–13	0–30
Lithite	0–25	0–25	75–100	75–86	3.7–5.0	0.0–0.5	3.9	2–6	0–16	43–50	5–8	0
Arkose	0–25	75–100	0–25	65–70	6.0–8.0	1.0–1.5	4.0	12–15	3–13	30–38	10–12	10–30

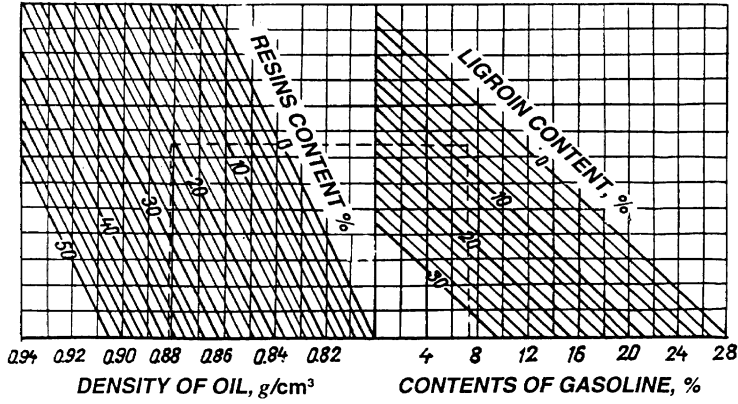

Fig. 11.20. Nomogram relating density of oil and contents of resins plus asphaltenes, "benzine" (gasoline) and lignoin.

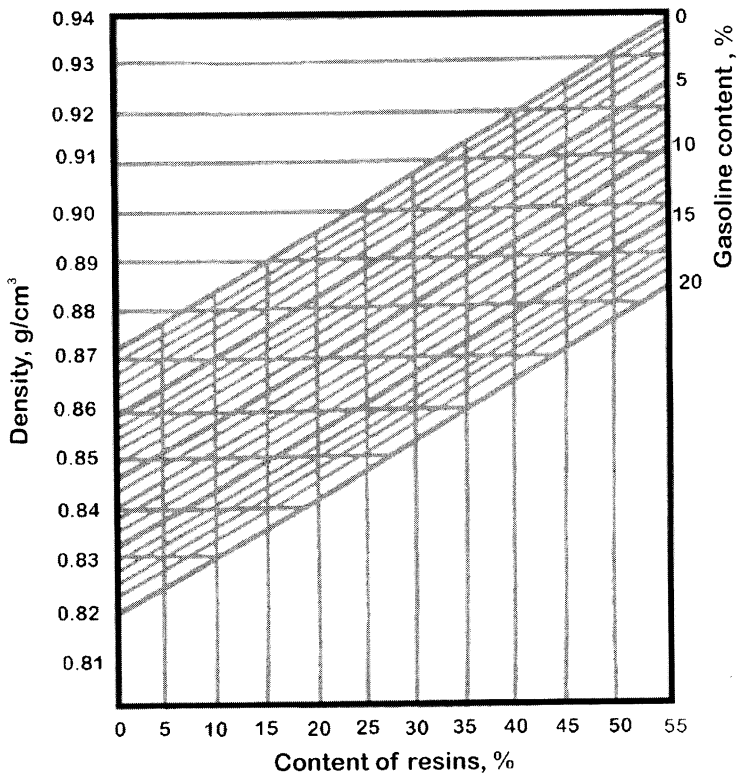

Fig. 11.21. Dependence of oil density on the contents of resins plus asphaltenes and "benzine" (gasoline).

TABLE 11.10

Kinematic viscosity of crude oils (in cst) as related to density and temperature

Average density (g/cm ³)	Temperature (°C)				
	10	20	30	40	50
0.82	5.6	4.2	2.8	2.8	1.4
0.83	5.6	5.6	4.5	3.9	2.5
0.84	11.2	9.9	5.6	5.4	4.3
0.85	14.0	12.9	7.9	5.8	5.2
0.86	20.5	13.7	9.4	6.5	5.6
0.87	22.4	20.3	12.4	10.5	7.6
0.88	39.2	23.2	18.3	11.7	10.3
0.89	53.0	32.6	21.9	14.4	11.0
0.90	86.4	50.3	30.9	22.7	15.1
0.91	118	94.5	50.5	30.2	24.1
0.92	—	133	89.2	53.7	33.6
0.93	—	356	178	111	55.8
0.94	—	—	178	178	89.2

where T is the temperature (in °C), v_0 is the kinematic viscosity (in cst) at $T = 0^\circ\text{C}$, which is equal to

$$v_0 = a \exp(c\gamma) \tag{11.67}$$

where γ is the crude oil density (in g/cm³) and a and c are empirical coefficients, a being the crude oil viscosity when $T = 0$ and $\gamma = 0$. The numerical coefficient b in Eq. 11.66 also depends on the crude oil density according to the following equation:

$$b = m\gamma - n \tag{11.68}$$

where m and n are numerical coefficients that can be estimated from the experimental data.

Substituting Eqs. 11.67 and 11.68 into Eq. 11.66, one obtains

$$v = a \exp(c\gamma - m\gamma T + nT) \tag{11.69}$$

or, after taking logarithms, one can obtain the equation in the following form

$$\lg v = a_0 + a_1\gamma - a_2\gamma T + a_3T \tag{11.70}$$

Coefficients a_i in Eq. 11.70 are calculated from the data presented in the correlation tables and Figs. 11.22 and 11.23.

Substituting numerical values of coefficients a_i into Eq. 11.70, one obtains

$$\lg v = 16.6\gamma - 0.100\gamma T + 0.072T - 12.8 \tag{11.71}$$

In SI units Eq. 11.71 becomes

$$\lg v = 0.0166\gamma - 0.0001\gamma T + 0.072T - 12.8 \tag{11.72}$$

where γ is in kg/m³, T is in °C, and v is in m²/sec.

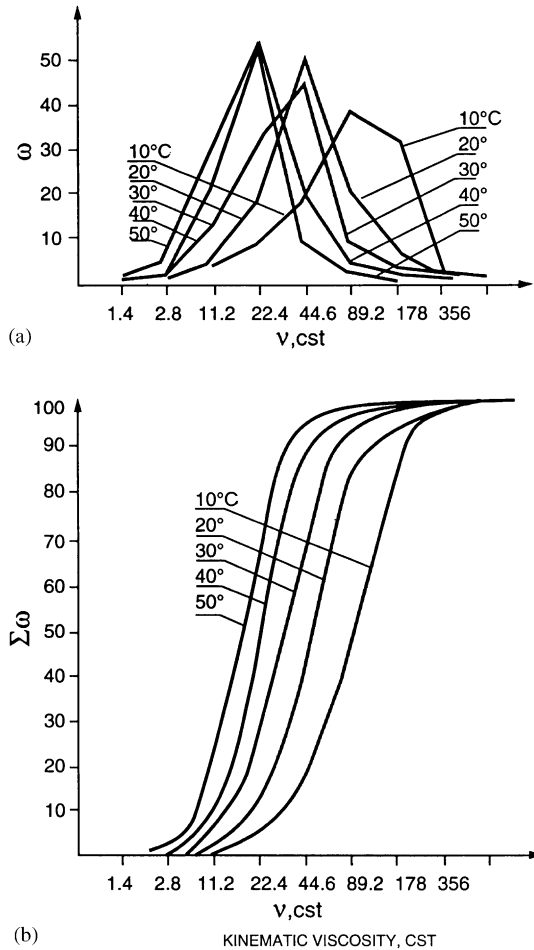

Fig. 11.22. Statistical distribution (a) and cumulative probability (b) of oil viscosity at five different temperatures (after Buryakovsky and Dzhevanshir, 1992).

Dynamic viscosity can be obtained combining Eqs. 11.65 and 11.69:

$$\mu = a\gamma \exp(c\gamma - m\gamma T + nT) \quad (11.73)$$

Substituting Eq. 11.37 into Eq. 11.69, one obtains an expression relating the kinematic viscosity of crude oil to the content of resins plus asphaltenes

$$v = a' \exp(c'R - m'RT + n'T) \quad (11.74)$$

where a' , c' , m' , and n' are empirical coefficients.

After taking logarithms of Eq. 11.74, one obtains

$$\lg \gamma = 0.6 + 0.0565R - 0.00034RT - 0.083T \quad (11.75)$$

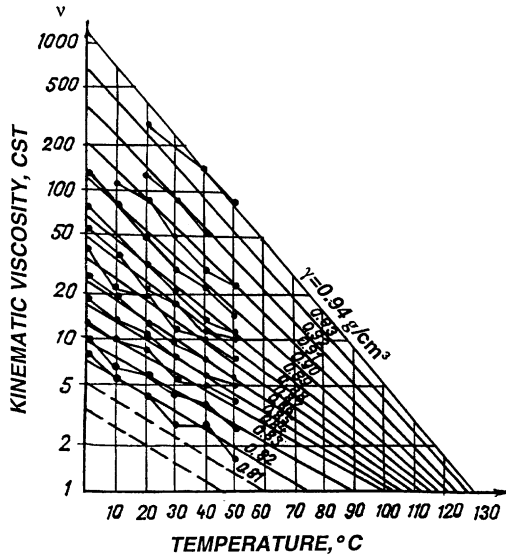

Fig. 11.23. Relationship among the kinematic viscosity (v), oil density (γ), and temperature (after Buryakovsky and Dzhevanshir, 1992).

Thus, the empirical equations of the relationships among composition, properties of the crude oil, and temperature may be derived using the experimental data. These equations are not only of practical value, but also of theoretical interest.

From the practical point of view, extrapolation of graphical or analytical models beyond the limits of the experimental data is of great interest. For example, extrapolation of graphs in Fig. 11.23 or using Eq. 11.72 for temperatures above 50°C enables one to predict the viscosity of crude oils of different densities at temperatures up to 100–120°C (at depths of 5500–6000 m). Rocks at these depths are most likely to contain gas-condensate fluids due to the low viscosity of fluids at such temperatures.

In the near-surface rocks (with an average annual temperature of + 14.5°C) crude oil is degraded into an asphalt-like material with a density of 1.0–1.1 g/cm³. Such deposits of bituminous sands are known to occur at outcrops of oil reservoirs in different parts of the world.

11.3. MODELS OF DYNAMIC GEOLOGIC SYSTEMS

As a rule, geologic systems, with subsequent technologic impact change either in “geologic” or “technologic” time scale. Thus, in order to develop adequate dynamic models of geologic and technologic processes, it is necessary to introduce time factor.

The time factor is of a special importance for the problems of any forecasting. Such problems indeed call for the creation and application of the mathematical models. The successful forecast may depend on the historical evaluation of

the geologic system under study (Buryakovsky et al., 1982; Buryakovsky and Chilingarian, 1991b).

The necessity to take geologic time into account meets with significant difficulties. One of the reasons for this difficulty is the use of absolute and relative geologic time scales. The difference between them is substantial: the absolute time scale has the beginning common for the entire Earth, which is not an attribute of the relative time scale based on paleontology and stratigraphy. Another reason is the lack of reproducibility of the geologic time in physical and chemical experiments.

Two methods in constructing the dynamic geologic models may be offered: *analytical* and *statistical*. The better approach in modeling such systems is the combination of mathematical analysis (i.e., differential equations) with the statistical-probabilistic assignment of numerical values for the parameters, causing the change in dynamic geologic systems. This approach allows the deterministic description of main features of the dynamics of the geologic systems. At the same time, it allows to account for the statistical-probabilistic nature of various geologic parameters, which cause the evolution of the systems. The implementation of analytical solution is accomplished using the statistical sampling technique or the so-called Monte Carlo method.

11.3.1. Analytical approach

Two important issues must be addressed before constructing analytical models:

1. The key properties of the system under study, as well as those of the surrounding rocks, should be defined. These properties should be described by strictly defined quantitative constraints.
2. The limitations assumed in describing these properties should be clearly delineated and should reflect the substance of a particular geologic system.

It is natural to choose as the main parameters those properties of the system and of the surrounding rocks, which would stimulate or restrain the course of the geologic processes.

In the following discussion, the writers use as synonyms the properties of the geologic system and their respective parameters. They may have a dual nature, i.e., they may be either deterministic or stochastic, depending on the formalization approach at each stage of simulation of a geologic system.

Two significant assumptions ought to be made while developing the differential equations of geologic processes.

1. The rate of change of the geologic system, or the speed of the geologic process, is proportional to the state of the system.
2. Influence of various natural factors is proportional to the product of the number (or quantitative estimates) of the events accelerating the process by the number (or quantitative estimates) of the events retarding the process.

The first assumption leads to the differential equation similar to

$$dx/dt = \varepsilon(t)f(x) \quad (11.76)$$

where x is a variable (quantitatively measured natural factor) describing the evolution of geologic system, $\varepsilon(t)$ is a coefficient of proportionality (generally

time-dependent), and $f(x)$ is any function of the variable x . In the case of a multiphase process, a system of Equations 11.76 type is written jointly.

The second assumption allows to put together a system of differential equations, which takes into account the effects of interrelationships among variables:

$$\begin{aligned} dx_1/dt &= \varepsilon_1(t)f_1(x_1) + \gamma_{12}(t)f_1(x_1)f_2(x_2) \\ dx_2/dt &= \varepsilon_2(t)f_2(x_2) + \gamma_{21}(t)f_1(x_1)f_2(x_2) \end{aligned} \quad (11.77)$$

where x_1 and x_2 are variables (natural factors) accelerating and retarding the process, respectively; $\gamma_{12}(t)$ and $\gamma_{21}(t)$ are interdependency quotients of these variables (or natural factors), which are generally time-dependent.

In some particular cases, the factors ε and γ may not be time-dependent, i.e., they are constant. In those cases, Eq. 11.76 forms the so-called “model of proportional effects”, or an “organism growth model” (Volterra, 1976).

Various functions of the affecting parameters can be used in Eqs. 11.76 and 11.77. This creates the necessary diversity in mathematical descriptions of the dynamics of the geologic systems. For example, when $f(x) = x$, the process in Eq. 11.76 is described by the exponential curve; when $f(x) = x(a - x)$, where a is a constant, process is described by the logistical curve (S-like or the Gompertz curve), etc.

The signs of ε and γ quotients in Eqs. 11.77 may vary. If the first equation has positive ε_1 and negative γ_{12} , then the two sign combinations are possible for the ε_2 and γ_{21} in the second equation. In the case of negative ε_2 and positive γ_{21} , the processes of system construction and destruction are antagonistic. In the case of positive ε_2 and negative γ_{21} , the processes merge into a single process controlled by the same natural factors, and the prevalence of the constructive component over the destructive one depends on the relation between these factors.

Depending on the signs of ε and γ , the geologic processes can be stable or unstable in time (Fig. 11.24). The former case is characterized by a point (center) or a convergent spiral on the phase plane in the (x_1, x_2) coordinates. The latter case is characterized by a saddle or a divergent spiral.

Taking into account the specifics of geologic time–space continuum, the mathematical models (Eqs. 11.76 and 11.77) allow to forecast the status, structure, and behavior of a geologic system at depths not yet studied through geologic techniques, assuming a normal stratigraphic succession of consecutive time intervals.

11.3.2. Statistical approach

Statistical approach, based on the empirical data, is simpler than the analytical one and is justified from the viewpoint of lithosphere evolution. It is based on the inference of interconnections through generalization, analysis, and comparison of the structural–functional features of geologic systems at certain discrete moments of the geologic time. Approximation of the discrete (discontinuous) data by a continuous function allows to obtain an empirical equation for a parameter (or a set of parameters) of the geologic system under study as a function of time.

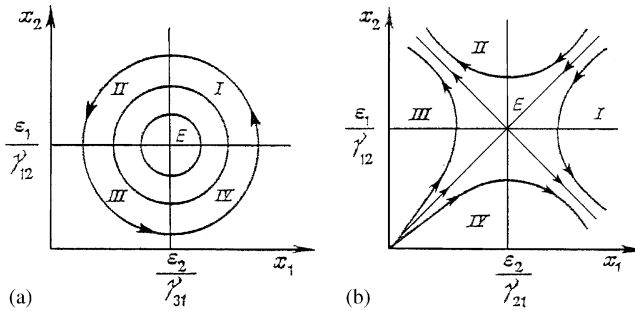

Fig. 11.24. Phase diagrams of the solution of Eqs. 11.77. *I–IV* – Specific areas of phase space. (a) $\varepsilon_1 > 0$, $\varepsilon_2 < 0$, $\gamma_{12} < 0$, $\gamma_{21} > 0$; (b) $\varepsilon_1 > 0$, $\varepsilon_2 > 0$, $\gamma_{12} < 0$, $\gamma_{21} < 0$.

As an example, the equation expressing the relationship between shale (clay) porosity and geologic age and taking into account burial depth and lithology, is presented here (Buryakovskiy et al., 1982, 1990).

The relationship between porosity of shales and depth of burial was studied by numerous investigators (e.g., Rieke and Chilingarian, 1974). As shown in Fig. 11.25, this relationship varies from one area to another. This is due to the fact that porosity of argillaceous sediments is a complex function of numerous natural factors, often superimposed on each other. These factors include:

- (1) geologic age;
- (2) effective stress (total overburden stress minus the pore pressure);
- (3) lithology;
- (4) mineralogy;
- (5) tectonic stress;
- (6) speed of sediment deposition;
- (7) thickness of sedimentary formations;
- (8) shape and sorting of grains;
- (9) amount and type of cementing material;
- (10) chemistry of interstitial fluids.

This multitude of variables complicates the quantitative evaluation of the influence of individual factors on the porosity of argillaceous sediments.

The following formula by Dobrynin (1970), for example, enables quantitative evaluation of the role played by various factors in forming porosity of shale:

$$\phi = \phi_0 \exp(-0.014\beta_c D) \quad (11.78)$$

where ϕ_0 is the initial porosity of clay, ϕ the porosity of shale at a depth D (in m), and β_c the coefficient of irreversible compaction (MPa^{-1}).

Using this formula, the writers plotted a family of straight lines on a semilogarithmic paper (Fig. 11.26). The actual compaction curves of argillaceous rocks are superimposed on this figure. Inasmuch as the coefficient of irreversible compaction β_c (in 10^{-3} , MPa^{-1}) for each one of the straight lines (Eq. 11.78) is known, it is possible to determine graphically its average value for actual curves of different geologic age:

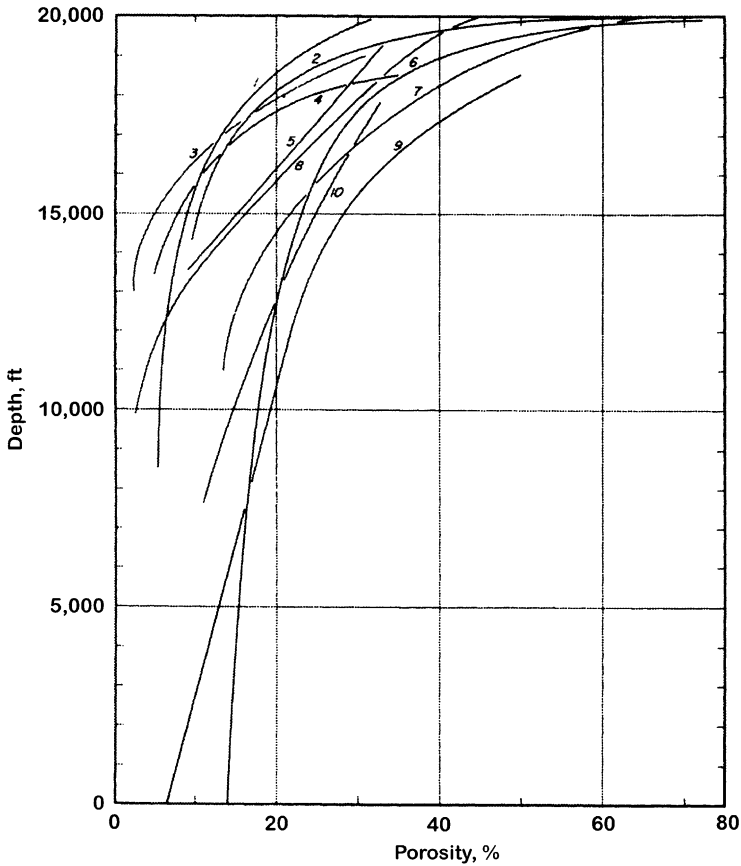

Fig. 11.25. Relationship between porosity and depth of burial for shales and argillaceous sediments. 1 – Proshlyakov (1960); 2 – Meade (1966); 3 – Athy (1930); 4 – Hosoi (1963); 5 – Hedberg (1936); 6 – Dickinson (1953); 7 – Magara (1968); 8 – Weller (1959); 9 – Ham (1966); 10 – Foster and Whalen (1966) (after Rieke and Chilingarian, 1974).

for the Devonian deposits (Weller, 1959), $\beta_c = 58.5$; for the Mesozoic deposits (Proshlyakov, 1974; Dobrynin, 1970), $\beta_c = 42.8$; for the Oligocene–Miocene deposits (Vassoyevich and Bronovitskiy, 1962), $\beta_c = 33.6$; for the Middle Pliocene deposits (Durmishyan, 1973) of Absheron Peninsula and Absheron Archipelago, $\beta_c = 42.1$; for the southwestern part of Absheron Peninsula and northern part of Baku Archipelago, $\beta_c = 27.1$; and for the southern part of Baku Archipelago, $\beta_c = 19.3$.

As shown in Eq. 11.78, with the exception of depth, the effects of all other variables are included in the coefficient of irreversible compaction β_c . Correlation of this coefficient with the geologic age and lithology becomes apparent upon comparison of curves of different geologic age obtained for areas having different lithologies (Fig. 11.26).

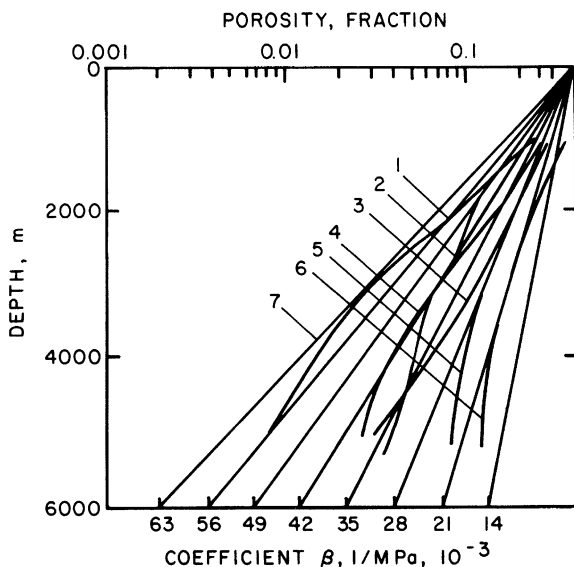

Fig. 11.26. Relationship between porosity and depth of burial for various shales. 1 – Weller (1959); 2 – Aralsor super-deep well SG-1 (USSR); 3 – Vassoyevich and Bronovitskiy (1962); 4 – Absheron Peninsula and Archipelago, Azerbaijan; 5 – southwestern part of Absheron and northern part of Baku Archipelago, Azerbaijan; 6 – southern part of Baku Archipelago and Lower Kura Depression, Azerbaijan; 7 – family of calculated porosity/depth curves (after Buryakovskiy et al., 1982).

Although many other factors influence compaction, geologic age and lithology (ratio of shales to the total thickness of rocks) affect the complex diagenetic processes occurring in a subsiding basin sediments, with a distinct geothermal gradient. The coefficient of irreversible compaction, β_c , is related to the geologic age and lithology as follows:

$$\beta_c = (26.61 \log A_t - 8.42) \times 10^{-3} \quad (11.79)$$

$$\beta_c = (14.0 - 166.6 \log \chi) \times 10^{-3} \quad (11.80)$$

where A_t is the geologic age in millions of years, and χ a ratio of thickness of shales to the total thickness of siliciclastics.

On combining Eqs. 11.78–11.80, an equation relating porosity to geologic age, lithology, and depth is obtained:

$$\phi = \phi_0 \exp[-0.014(13.3 \log A_t - 83.25 \log \chi + 2.79) \times 10^{-3} D] \quad (11.81)$$

where ϕ_0 is the initial porosity of argillaceous sediments, and D is the depth in meters.

A nomogram, presented in Fig. 11.27, enables rapid solution of Eq. 11.81. This nomogram was used to test the results obtained by (a) Hedberg (1926) for the Tertiary shales of Venezuela, (b) Stetyukha (1964) for the Tertiary shales of the

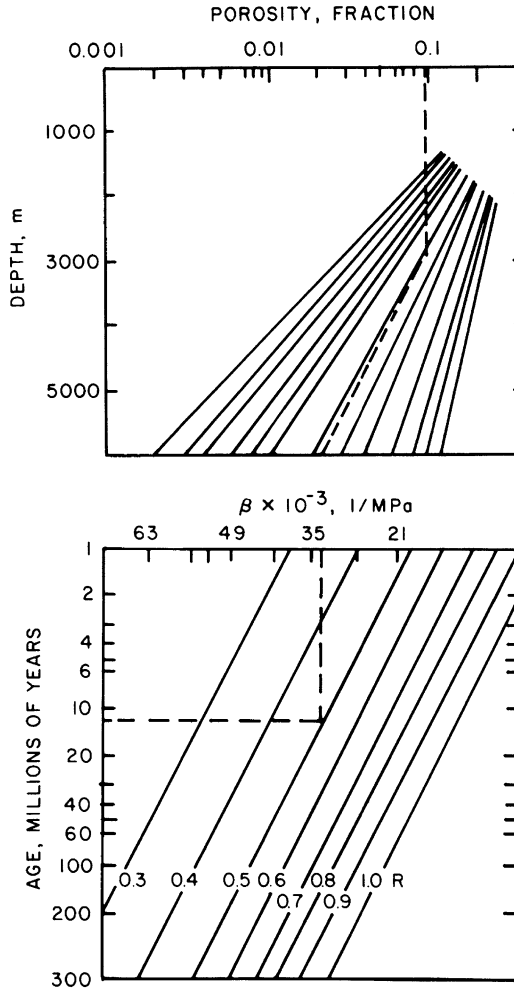

Fig. 11.27. Nomogram for determination of porosity at a particular depth of burial using geologic age and lithology (ratio of thickness of shales/total thickness of terrigenous complex) as controlling factors $R = X$.

northeastern part of Pre-Caucasus, and (c) Durmishyan (1973) for the Kala Formation of Absheron Peninsula and Archipelago. Comparison of data obtained from Fig. 11.27 (nomogram) and actual field data is presented in Fig. 11.28. The absolute error does not exceed 3%. The relative error gradually increases with increasing absolute value of porosity and varies from 5% to 30%. The difference between the calculated values and actual field data is probably due to the fact that calculated values do not take into consideration all the factors, which influence porosity. Nevertheless, Eq. 11.81 gives satisfactory, practically usable results.

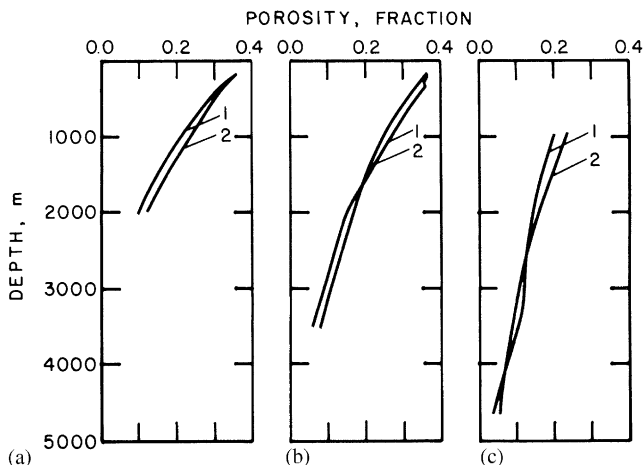

Fig. 11.28. Comparison of actual porosity and that obtained from nomogram (after Buryakovskiy et al., 1990). (a) Venezuela, (b) Pre-Caucasus Region, (c) Absheron Peninsula and Archipelago. 1 – Actual porosity, 2 – calculated porosity.

11.3.3. Combination of analytical and statistical approaches

11.3.3.1. Sediment compaction

The rate of compaction of sediments depends on the lithology, rate of sedimentation, and the tectonic regime of the sedimentation basin. One of the most important properties determining the degree of compaction of sediments is the ease of release (expulsion) of interstitial waters: sand gives up pore waters easier than clay. The presence of thick strata of water-saturated clays in a sedimentary section retards the compaction. A rapid rate of sedimentation also retards the compaction process. On the other hand, intensive tectonic activity may result in rapid lithification.

An attempt was made by Buryakovskiy et al. (1982) to describe systematically the process of sediment compaction. The curves showing changes in the porosity with depth may be described by the so-called “organism-growth model”, equivalent to the “model of proportional effects”.

The difference between the “model of organism growth” and the “model of proportional effects” is as follows: the former is based on the equality of the rate of change in variable y to the value of this variable reached by a certain moment of time t , i.e.,

$$dy/dt = cy \quad (11.82)$$

which leads to an exponential dependence of the variable y on time t :

$$y = y_0 e^{ct} \quad (11.83)$$

where c is the factor of proportionality.

The second model is derived from the equality of absolute change in the variable y to the value of this variable reached by a certain moment of time, i.e.,

$$dy = cy \tag{11.84}$$

resulting in an exponential dependence of the variable y on the factor of proportionality c :

$$y = y_0 e^c \tag{11.85}$$

If the process is affected by the sum of different factors, then the equation becomes

$$y = y_0 \exp\left(\sum_{i=1}^n c_i\right) \tag{11.86}$$

This model can be transformed into a model of multiplication

$$y = y_0 \prod_{i=1}^n X_i \tag{11.87}$$

where $X_i = \exp(c_i)$, and $\prod_{i=1}^n X_i$ is a generalized measure of the change in variable y .

Based on the principle of equality of the rate of evolution of compaction process to the obtained value of some parameter characterizing this process, the writers obtained a number of models:

(a) Model of sediment compaction (compaction model by Terzaghi, 1961):

$$U_t = 1 - h_t/h_0 = 1 - \{[h_{\min} \exp(c_h h_{\min} t)]/[h_{\min} - h_0(1 - \exp(c_h h_{\min} t))]\} \tag{11.88}$$

where U_t is the relative compaction of sediments, h_0 , h_t , and h_{\min} are the thicknesses of the layer before compaction, at time t , and for the completely compacted rock (lowest, minimum value), respectively; and c_h is the factor of proportionality.

(b) Model of density:

$$\gamma_t = [\gamma_0 \gamma_{\max} \exp(c_\gamma \gamma_{\max} t)]/[\gamma_{\max} - \gamma_0(1 - \exp(c_\gamma \gamma_{\max} t))] \tag{11.89}$$

where γ_t , γ_0 , and γ_{\max} are rock densities at time t , before compaction, and for the completely compacted rock, respectively; and c_γ is the factor of proportionality.

(c) Model of porosity:

$$\phi_t = [\phi_0 \exp(-c_\phi t)]/[1 - \phi_0(1 - \exp(-c_\phi t))] \tag{11.90}$$

where ϕ_0 and ϕ_t are porosities before and at a certain time during the process of compaction of sediments; and c_ϕ is the factor of proportionality.

Models based on Eq. 11.87 were widely used in predicting reservoir-rock properties and physical properties of terrigenous rocks at different geological and physical environments of the South Caspian Basin, Daghestan Plain, and the Middle Caspian Basin at depths of 6–9 km. Many examples are given by Buryakovsky et al. (1982, 1990, 2001).

11.3.3.2. Simulation of rock properties

The main factor of postsedimentary changes of any deposits is the compaction of overlying strata, resulting in the continuous decrease of the initial porosity of

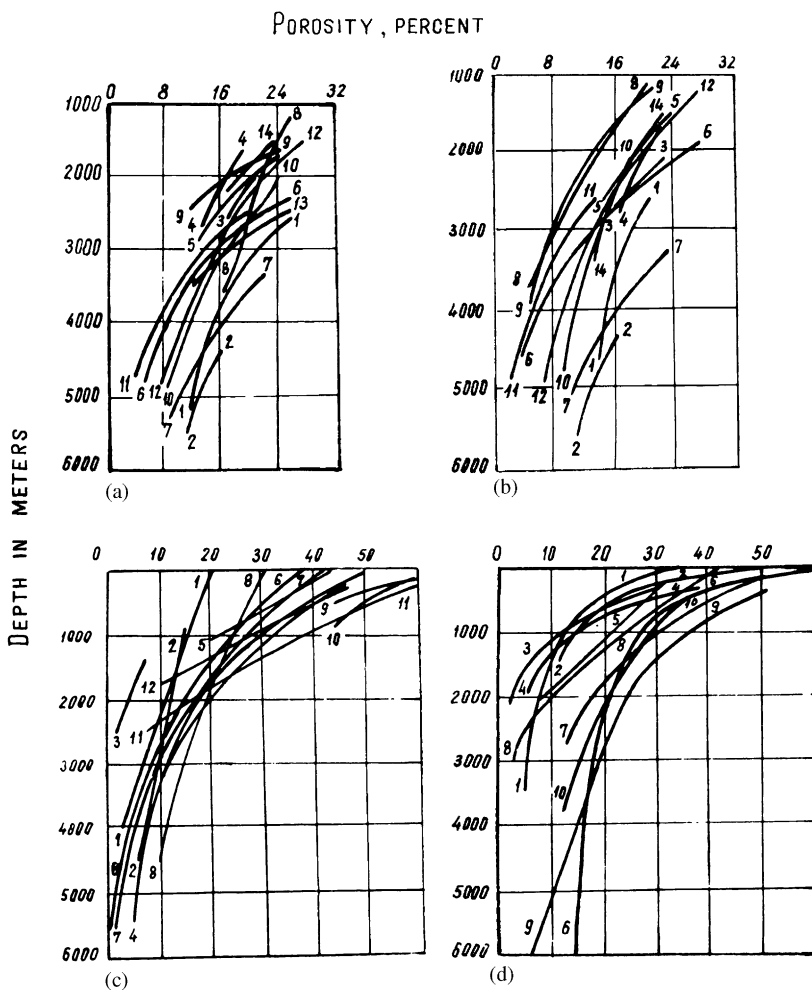

Fig. 11.29. Relationship between porosity and depth of burial for various types of sediments and rocks (after Buryakovskiy et al., 2001). (a) Sandstones, (b) siltstones in the fields of the NW portion of the South Caspian Basin: 1 – Dzhannub, 2 – Zyrya, 3 – Surakhany, 4 – Karachukhur, 5 – Zyk, 6 – Gum Deniz, 7 – Gousany, 8 – Bukhta Il'icha, 9 – Patamdar, 10 – Karadag, 11 – Padar, 12 – Kyurovdag, 13 – Karabagly, 14 – Kalmas. (c) Carbonates in the following regions: 1 – Scythian Plate, Upper Cretaceous limestones; 2 – Western Kuban Trough, Upper Devonian limestones; 4-8 – Southern Florida, Cenozoic and Mesozoic carbonates: 4 – average, 5 – Eocene, 6 – Paleocene, 7 – limestone, 8 – dolomite, 9-10 – deepwater carbonate mud, 11-12 – chalk. (d) Argillaceous sediments and rocks by: 1 – Proshlyakov; 2 – Meade; 3 – Athy; 4 – Hosoi; 5 – Hedberg; 6 – Dickinson; 7 – Magara; 8 – Weller; 9 – Ham; 10 – Foster and Whalen.

sediments with depth (Fig. 11.29). As shown in Fig. 11.29, all curves may be described by an exponent, which suggests a single concept for solution of the problem of mathematical simulation of the process of compaction and lithification of sediments and prediction of the properties of rocks (Buryakovskiy, 1993).

This problem is solved by making three assumptions and using their implications:

- (1) The process of postsedimentary changes and consolidation of sediments is affected by many natural factors.
- (2) The effect of each factor is unique and differs from those of other factors.
- (3) The final result is the sum of individual influences of all natural factors on the sediments during their transformation into rocks.

Thus:

- (A) Assumptions (1) and (2) indicate that the individual influences of any factor on the overall result of consolidation are small and are inversely proportional to the number of factors.
- (B) Assumption (2) indicates that the influence of each factor is not equal to that of others.

The above discussion allows one to reach the following conclusions:

(1) Small influences of each i th factor resulting in a relative change in the volume of consolidating sediments, U , can be represented as dU_i/U_i , whereas the cumulative influences of all the factors can be represented by $\int dU_i/U_i$. This expression is somewhat analogous to Hooke's law: $dU_i/U_i = -\beta\sigma$, where β is the modulus of elasticity and σ is the affecting stress. If $\beta\sigma$ is understood not only as the effect of static load, but also as the influence of any i th factor, one would obtain:

$$\int_{U_0}^U dU_i/U_i = \sum_{i=1}^n c_i \tag{11.91}$$

where U_0 is the rate of initial compaction and c_i the influence of i th factor.

Hence, one can derive the following equations:

$$U_t = U_0 \exp\left(\sum_{i=1}^n c_i\right) \tag{11.92}$$

and

$$U_t = U_0 \prod_{i=1}^n x_i \tag{11.93}$$

where U_t is the rate of compaction at the present moment of time, $x_i = \exp(c_i)$, and $\prod_{i=1}^n x_i$ is a generalized measure of a change in parameter U .

(2) Differences in the physicogeological nature of factors affecting the rock consolidation require their presentation in the form of relative dimensionless values that correspond to a formal type of individual influence dU_i/U_i . The influence of the i th factor ($dU_i/U_i \sim c_i$) is evaluated (a) from the results of direct laboratory measurements on cores (reproduction of Hooke's law), (b) by using analogies when the direct physical simulation is impossible, or (c) by actual field observations and measurements.

Based on the above assumptions, a multivariable model was proposed for evaluation of the rate of compaction and diagenetic changes of sediments after their

deposition in the sedimentary basin. The general form of this model is

$$U_t = U_o \prod_{i=1}^n x_i \quad (11.94)$$

where U_o is the rate of initial compaction of sediments and U_t is the rate of compaction at a given depth and at a certain geologic time t , and x_i is the modeling coefficient.

In selecting the modeling coefficients, one must consider: (1) conditions of accumulation of terrigenous or carbonate sediments, (2) their postsedimentary changes (diagenesis and catagenesis or epigenesis), and (3) the structural evolution of the region. One should recognize the role of different factors, such as external (pressure, temperature, etc.) and internal (lithology, mineralogic composition, cementation, etc.).

The characteristic feature of coefficients x_i is their independence, which is a necessary condition for the model (Eq. 11.94). Numerical values of x_i coefficients corresponding to the c_i factors are given in Table 11.11. Their evaluation is carried out according to the initial data of experimental and field studies (Buryakovskiy et al., 1982, 1990).

Modeling coefficients take into account the influence of major geological (natural) factors on compaction and other diagenetic and catagenetic changes of rocks. These factors are as follows:

- (1) geologic age (in million years — My),
- (2) number of tectonic (orogenic) cycles (in dimensionless tectonic-stratigraphic units),
- (3) depth of burial (in km),
- (4) temperature (in °C),
- (5) rate of sedimentation (in m/My),
- (6) content of quartz in sandstones (in wt%),
- (7) content of smectites (montmorillonite) in shales (in wt%),
- (8) degree of cementation (content of CaCO_3 in wt%),
- (9) sorting coefficient of Trask, and
- (10) degree of homogeneity of carbonate rocks (dimensionless).

Ranges in the absolute values of natural factors are shown in Table 11.11. Scales of absolute values of natural factors are presented in this table. Model (Eq. 11.94) requires a normalized form of natural factors. Normalization equations for natural factors are shown in Table 11.12. These equations, which relate the absolute and the normalized scales, were obtained from data in Table 11.11.

The number of natural factors used in Eq. 11.94 varies depending on the type of rocks. The influence of a particular factor is also different for each type of rocks. There are three types of natural factors with a different influence on rocks: strong, moderate, and weak.

The “strong” factors affecting the compaction of sandstones are as follows: geologic age and depth of burial. The factors of “moderate” influence: the number of tectonic cycles (epochs), quartz content, and cementation (CaCO_3 content). The “weak” factors: rate of sedimentation, sorting coefficient of Trask, and formation temperature. Thus, eight natural factors affect compaction of sandstones.

TABLE 11.11

Numerical values of factors determining the degree of compaction

Factor	Normalized scale (T_f)										
	0	0.1	0.2	0.3	0.4	0.5	0.6	0.7	0.8	0.9	1.0
Scales of absolute values of factors											
Absolute geological age, A_t (My)	0	50	100	150	200	250	300	350	400	450	500
Dynamic deformation, N (tectonic-strat. unit)	0.73	0.85	1.00	1.17	1.37	1.60	1.88	2.20	2.58	3.01	3.53
Depth of burial, D (km)	0	0.6	1.2	1.8	2.4	3.0	3.6	4.2	4.8	5.4	6.0
Formation temperature, T (°C)	0	20	40	60	80	100	120	140	160	180	200
Rate of sedimentation, R_d (m/My)	20	30	50	80	100	200	300	500	800	1,000	2,000
Content of quartz in sandstones, Q (wt%)	100	90	80	70	60	50	40	30	20	10	0
Content of smectites in clays, M (wt%)	0	5	10	15	20	25	30	35	40	45	50
Cementation index, C (wt%)	0	3	6	9	12	15	18	21	24	27	30
Sorting of sandstones, S_{ss}	1	2	3	4	5	6	7	8	9	10	—
Sorting of shales, S_{sh}	—	10	9	8	7	6	5	4	3	2	1
Homogeneity of carbonates, S_{cr}	0	1	2	3	4	5	6	7	8	9	10

TABLE 11.12

Equations of normalization for natural factors (see Table 11.11)

Factor	Equation of normalization
Absolute geological age, A_t (My)	$T_A = 0.002A_t$
Dynamic deformation, N (tectonic-strat. units)	$T_N = 0.2 + 1.46 \log N$
Depth of burial, D (km)	$T_D = 0.167D$
Formation temperature, T ($^{\circ}\text{C}$)	$T_t = 0.005T$
Rate of sedimentation, R_d (m/My)	$T_V = 0.5(\log R_d - 1.3)$
Content of quartz in sandstones, Q (wt%)	$T_Q = 1 - 0.01Q$
Content of smectites in clays, M (wt%)	$T_M = 0.02M$
Cementation index, C (wt%)	$T_C = 0.033C$
Sorting coefficient of sandstones, S_{ss}	$T_{ss} = 0.1(S_{ss} - 1)$
Sorting coefficient of shales, S_{sh}	$T_{sh} = 0.1(11 - S_{sh})$
Homogeneity of carbonates, S_{cr}	$T_{cr} = 0.1S_{cr}$

Only five natural factors affect the compaction of carbonate rocks. The “strong” factors: geologic age, the number of tectonic cycles, depth of burial, and temperature. The “moderate” factor is the homogeneity level.

For shales, there are eight natural factors. The “strong” factors: geological age, depth of burial, and rate of sedimentation. The “moderate” factors: the number of tectonic cycles, content of smectites (montmorillonite), and cementation. The “weak” factors: the sorting coefficient and temperature.

Modeling coefficients are calculated using the following equation:

$$x_i = \exp(-a_j T_i) \quad (11.95)$$

where a_j is the coefficient of influence of normalized value T_i of any natural factor on the various rock properties x_i . Coefficients a_j were obtained by examining numerous experimental data (Buryakovsky et al., 1982; Chilingar et al., 1979) and are presented in the following table:

Rock type	Degree of influence of natural factors, a_j coefficient (Eq. 11.95)		
	Strong	Moderate	Weak
Reservoir rock	0.968	0.714	0.511
Caprock	2.996	1.833	1.309

Using modeling coefficients, one can calculate the Z factor:

$$Z = U_i/U_o = \prod_{i=1}^n x_i \quad (11.96)$$

The Z factor characterizes the relative compaction and other diagenetic changes of sediments, i.e., the relative consolidation of rocks. This factor is used for calculating

rock properties using the following equations:

$$\text{Porosity } \phi = \phi_o Z_1 \tag{11.97}$$

$$\text{Permeability } k = k_o(Z_1)^4 \tag{11.98}$$

$$\text{Density } \gamma = \gamma_{ma}(1 - \phi_o Z_1) \tag{11.99}$$

where ϕ_o and k_o are, respectively, the initial values of porosity and permeability before compaction of sediments, γ_{ma} is the density of matrix of consolidated rocks, and Z_1 is equal to:

$$Z_1 = \prod_{i=1}^n x_i / \left[1 - \phi_o \left(1 - \prod_{i=1}^n x_i \right) \right] = Z / [1 - \phi_o(1 - Z)] \tag{11.100}$$

is the relative change in porosity: ϕ/ϕ_o .

The results of the numerical simulation show that the modeling coefficients x_i represent adequately the influence of many geological factors on the petrophysical properties of rocks (Fig. 11.30).

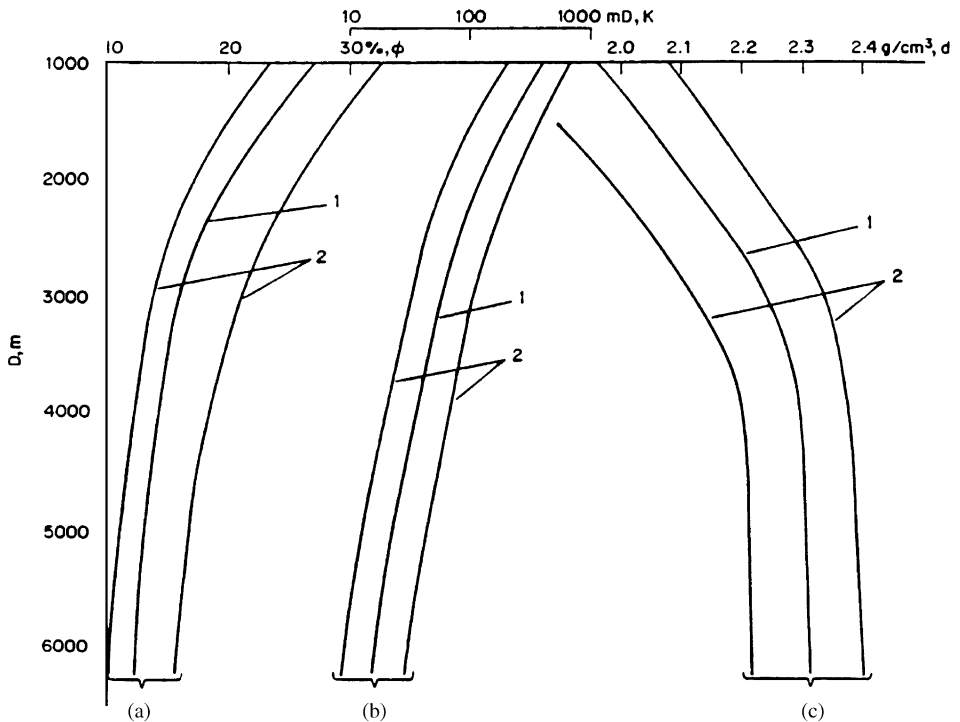

Fig. 11.30. Results of numerical simulation of Mesozoic reservoir-rock properties. (a) Porosity, (b) permeability, (c) density. 1 – Average curve, 2 – confidence limits. (After Buryakovskiy, 1993.)

Thus, the results of numerical simulation show that there is a significant difference between the reservoir properties of Mesozoic and Neogene rocks (Fig. 11.31). Geologic time is the main factor determining the rock compaction: porosity of Mesozoic sandstone is about two times lower than that of Neogene sandstone (Fig. 11.31a). Permeability of Mesozoic sandstone is 20 times lower than that of Neogene sandstone (Fig. 11.31c), as indicated by example 1 versus example 4.

Comparison of the results obtained by simulation of the clastic reservoir-rock properties (sandstones) with those of the carbonate rocks shows that carbonate rocks become compacted and consolidated faster than sandstones. This is obvious from examples 1 and 2 (Fig. 11.31).

The results of numerical simulation presented in examples 1 and 3 (Fig. 11.31) indicate that clays become compacted faster than sands.

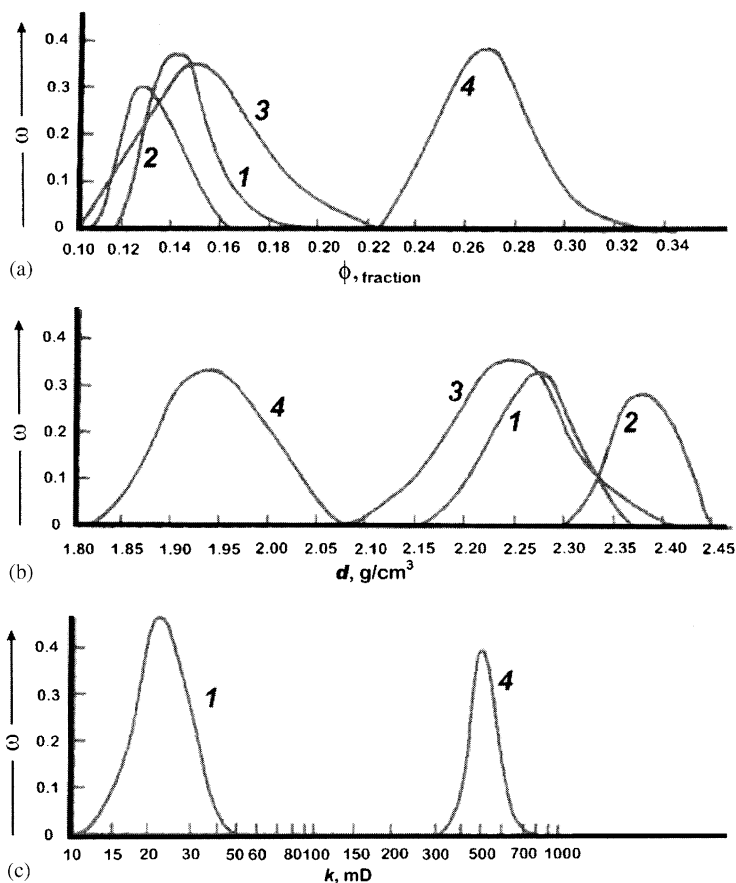

Fig. 11.31. Statistical distribution of petrophysical properties of rocks. (a) Porosity, (b) density, (c) permeability. Mesozoic rocks: 1 – sandstone, 2 – carbonates, 3 – shale. Cenozoic rocks: 4 – sandstone. ω – frequency. (After Buryakovskiy, 1993.)

11.3.3.3. Prediction of rock properties

To predict the reservoir rock and caprock properties at various depth of burial, the models of porosity ϕ , permeability k , and formation bulk density γ were used as mathematical descriptions of the rock properties (see Eqs. 11.97–11.100). Initial oil or gas saturation was evaluated from the following equation:

$$S_{o/g} = 1 - ak^{-b} \quad (11.101)$$

where a and b are the empirical coefficients.

Input data (used by the authors) for the prediction of properties of Neogene rocks of the South Caspian Basin were:

- Geologic age: 10–12 My
- Dynamic deformation: 1.1–1.2 tectonic-stratigraphic units²⁰
- Depth of occurrence: up to 6.5 km
- Formation temperature: up to 110°C
- Rate of sedimentation: 500–800 m/My
- Quartz content: 40–80%
- Carbonate cement content: 8–12%
- Trask sorting coefficient: 2–4
- Initial porosity before compaction: 0.35–0.45
- Initial permeability before compaction: 2000–3000 mD
- Density of rock matrix: 2.6–2.7 g/cm³
- Empirical coefficients in Eq. 11.101: $a = 0.80$ and $b = 0.225$.

The parameters under study were predicted up to a depth of 9,000 m (Figs. 11.32 and 11.33). These figures show that as stratigraphic depth (to the bottom of Middle Pliocene interval) and hypsometric depth (along the certain bed) increase up to 6,000 m, the absolute and effective porosity decrease from 19–20% to 14–15% and from 14–15% to 9–10%, respectively. The corresponding permeability of sandstones and siltstones decreases from 130–150 to 40–60 mD. At a depth of 9,000 m, porosity varies from 7% to 10%, whereas permeability changes from 2 to 11 mD. Table 11.13 shows the predicted values of reservoir-rock properties of the Productive Series of some offshore fields in the South Caspian Basin.

11.3.3.4. Prediction of hydrocarbon reserves

The model of determining hydrocarbon resources (a model of Eqs. 11.77 type, at $f_1(x_1) = V_1$ and $f_2(x_2) = V_2$, where V_1 and V_2 are hydrocarbon volumes in growing (V_1) and dwindling (V_2) accumulations) was proposed. At one-stage oil accumulation, the model is as follows:

$$V_1 = [BV_o \exp(\varepsilon_1 Bt)]/[B - V_o(1 - \exp(\varepsilon_1 Bt))] \quad (11.102)$$

where B is the volume of trap containing a hydrocarbon accumulation.

²⁰The intensity of subsidence of the sedimentary basin floor during the Middle Pliocene time decreased with depth, and increased in the direction from the Absheron Peninsula to the Absheron and Baku archipelagos and from the Cheleken Peninsula to the Turkmenian shelf, i.e., southward.

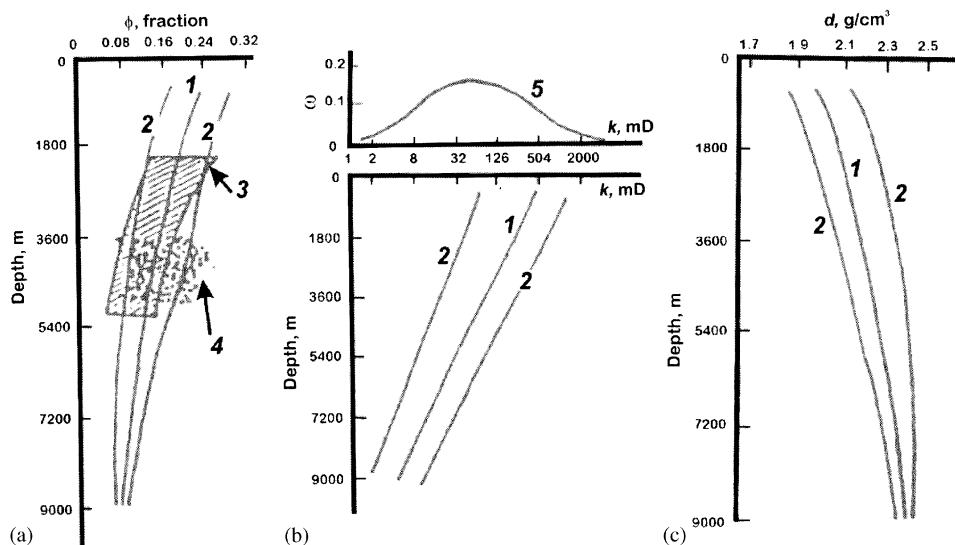

Fig. 11.32. Results of simulation of reservoir-rock properties in the South Caspian Basin (after Buryakovskiy et al., 1990). (a) Porosity, (b) permeability, (c) density. 1 – Average curve, 2 – confidence limits, 3-4 – core data, 5 – statistical distribution of actual (measured) permeability.

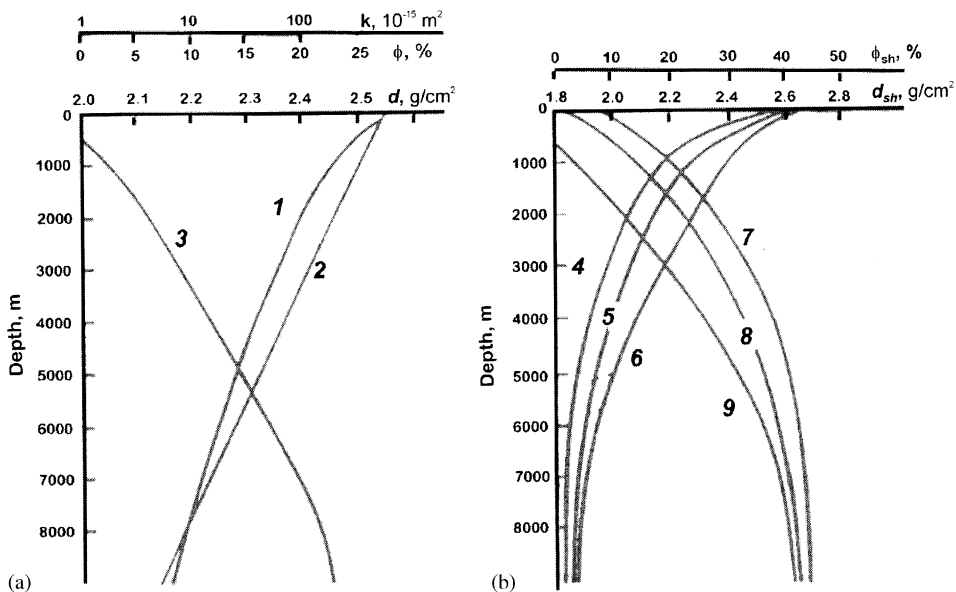

Fig. 11.33. Results of simulation of petrophysical properties of rocks (variation with depth) (after Buryakovskiy et al., 1990). (a) Reservoir rocks from Absheron region: 1 – porosity, 2 – permeability, and 3 – density; (b) shales from three regions of the South Caspian Basin: 4, 5, 6 – porosity, and 7, 8, 9 – density.

TABLE 11.13

Predicted reservoir-rock properties of some offshore formations in Azerbaijan

Suite	Depth (m)	Porosity (%)	Oil/gas saturation (%)	Effective porosity (%)	Permeability (mD)
Surakhany	200–1500	23	77	18	302
Sabunchi	200–2000	23	77	18	283
Balakhany	200–2500	23	76	18	287
Fasila	200–2500	23	76	18	287
NKG	300–2500	21	71	15	117
NKP	300–2500	23	77	18	280
KS	400–1500	23	73	17	139
PK	500–2000	23	77	18	298
KaS	700–2200	22	74	16	174

This model allows to forecast the extent of hydrocarbon accumulation and to evaluate the hydrocarbon resources locally or for a region as a whole (Fig. 11.34). As an example, the reservoirs of the deep-water zone of the South Caspian Basin have been used.

Using Eq. 11.102, a model of hydrocarbon reserves evaluation in individual traps was obtained. This model is a derivative of Eq. 11.102 and is formally similar to Eq. 11.94, where x_i are reservoir parameters for hydrocarbon reserves estimation using the volumetric method.

The formula used in calculating crude oil volume in situ is as follows:

$$V = Ah_{\text{eff}}\phi S_o \quad (11.103)$$

where V is the volume of oil accumulation, A is the reservoir area, h_{eff} is the thickness of oil-bearing formation (net pay), ϕ is the porosity, and S_o is the oil saturation.

Eq. 11.103 can be simplified if ϕS_o is replaced by the “effective saturated porosity” ϕ_{eff}^* :

$$V = Ah_{\text{eff}}\phi_{\text{eff}} \quad (11.104)$$

Some offshore structures of the South Caspian Basin are studied only by a sparse net of seismic lines, whereas the offshore areas adjacent to the oil and gas fields were not studied during exploration. In view of this problem, it was decided to use the mathematical methods. An algorithm and computer program was developed using the double Fourier series for uneven spacing of the initial data (Buryakovsky et al., 1990). Examples of structural maps on top of the Lower Productive Series along the northern slope of South Caspian Basin are presented in Fig. 11.35.

Effective oil and gas saturated thickness of a reservoir (net pay) was determined using the identification of layers using a cluster-analysis technique, i.e., by means of pattern recognition without preliminary training. For this purpose, sections studied using the well logs were utilized. Each section was divided into groups of beds with

*The writers propose that effective porosity is in effect intercommunicating porosity minus the irreducible fluid saturation.

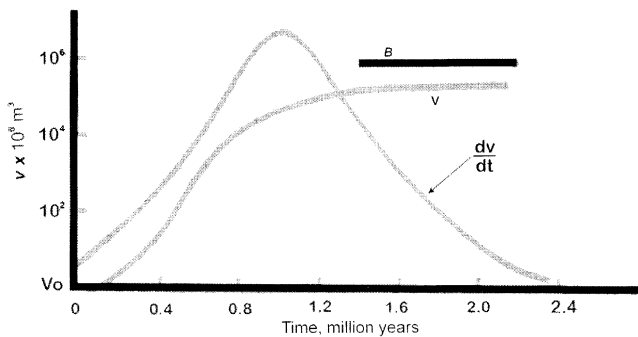
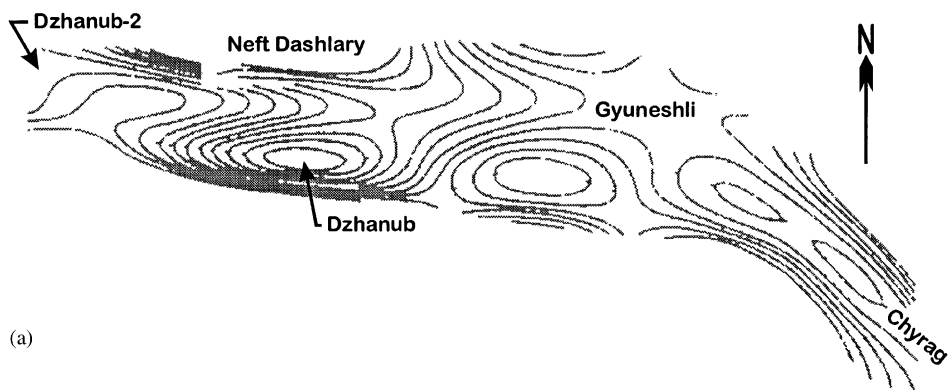
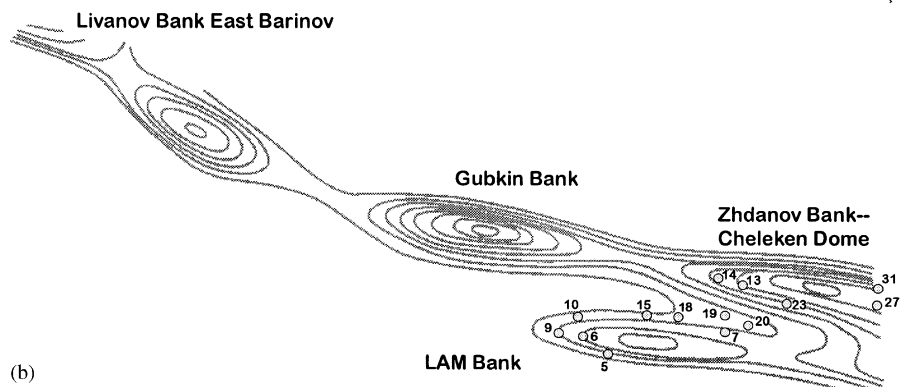

Fig. 11.34. Results of simulation of hydrocarbon accumulation in traps. B = volume of the trap, V = volume of trapped hydrocarbons. (After Buryakovsky et al., 2001, p. 404.)



(a)



(b)

Fig. 11.35. Simulated structural maps (after Buryakovsky et al., 1990). (a) At the base of Fasila Suite of the Productive Series of Azerbaijan, (b) at the base of Unit VIII of the Red-Bed Series of Turkmenistan.

definite reservoir-rock properties. These groups were identified by means of comparison with the well-testing results. An example of identification of beds and a measure of their subdivision into groups (correlation coefficient or generalized Euclidian distance) were used by Buryakovsky et al. (1990).

The ϕS_o (see Eq. 11.103) of reservoir rocks was evaluated by simulating processes of compaction and other diagenetic changes of sediments, as described above. Examples of simulation of reservoir-rock properties are presented in Table 11.13 (or in Fig. 11.36).

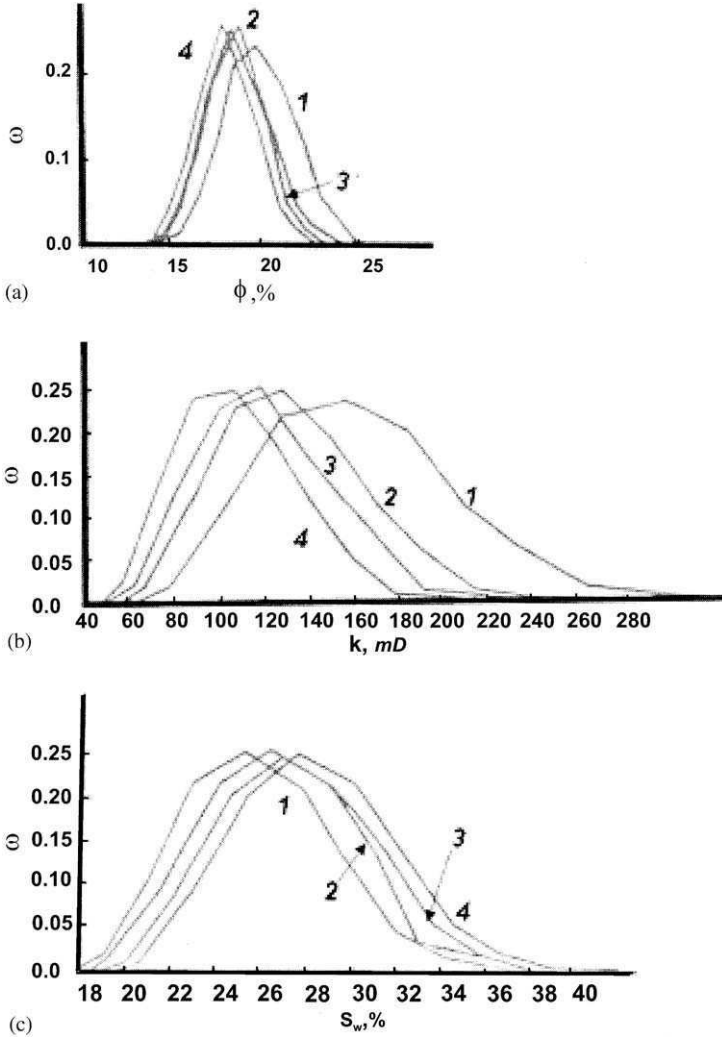

Fig. 11.36. Statistical distributions of calculated values of petrophysical properties of rocks. (a) Porosity (fraction), (b) permeability (mD), (c) residual water saturation (fraction). Formations: 1 – Balakhany; 2 – Fasila; 3 – NKP; 4 – PK. (After Buryakovsky, 2001, p. 406.)

Hydrocarbon volumes were calculated using the Monte Carlo technique at the interval-probable setting of reservoir parameters. As discussed by Abasov et al. (1984), such method of reserve evaluation is more preferable than evaluation using the average parameters. This allows one to obtain not an average value of reserves but their variation. Consequently, reliable intervals of real values of reserves (with the reliability coefficient fixed in advance) can be obtained.

11.3.3.5. Evolution of pore-fluid (formation) pressure

The description of processes of pore-fluid pressure generation and destruction is obtained from Eqs. 11.77, where $f_1(x_1) = p_1$ and $f_2(x_2) = p_2$ are pore-fluid pressures in the process of being increased and decreased, respectively.

Such dynamic model can be described by a system of nonlinear differential first-order equations as follows:

$$\begin{aligned} dp_1/dt &= \varepsilon_1 p_1 - \gamma_{12} p_1 p_2 \\ dp_2/dt &= -\varepsilon_2 p_2 + \gamma_{21} p_1 p_2 \end{aligned} \quad (11.105)$$

where $p_1 = p_1(t)$ is the pore-fluid pressure during the period of being increased, $p_2 = p_2(t)$ the pore-fluid pressure during the period of being decreased, ε_1 and ε_2 are coefficients of pore-fluid pressure change during the increasing and decreasing periods, respectively; and γ_{12} and γ_{21} are coefficients of interaction of natural factors determining either preservation or change of the pore-fluid pressure.

The system of Eqs. 11.105 describes the processes of generation, stabilization, preservation, and dissipation of pore-fluid pressures. Due to the difficulty in simultaneous experimental determination of the coefficients of pressure change and coefficients of opposite influence of some natural factors, numerical simulation using the models is possible in a practical case only when the coefficients having opposite influence may be neglected. For $\gamma_{12} = \gamma_{21} = 0$, Eqs. 11.105 is reduced to two equations, one of which describes the abnormal pore pressures, and the other, a drop to the normal hydrostatic pressure. At actual conditions, it is necessary also to take into account the self-retarding effect of the process, leading to the following equation:

$$p_1 = [p_{\max} p_o \exp(\varepsilon_1 p_{\max} t)] / [p_{\max} - p_o (1 - \exp(\varepsilon_1 p_{\max} t))] \quad (11.106)$$

where p_o is the initial value of the pore pressure (hydrostatic pressure of water at a depth where sedimentation began), p_{\max} is the maximum possible pore pressure at given conditions, and t is the time. The coefficient of proportionality, ε_1 calculated for the South Caspian Basin averages 0.02 1/(MPa/My).

The change in pressure with depth is assumed to be analogous to the change in time and may be described by an equation similar to Eq. 11.106. This assumption is probably true for the South Caspian Basin, taking into account a relatively young age of rocks, absence of noticeable structuring, one-phase formation of folded structure, normal bedding of sequential stratigraphic intervals, etc. Other factors can also influence the development of abnormal pore pressure, but in the South Caspian Basin they probably play a subordinate role.

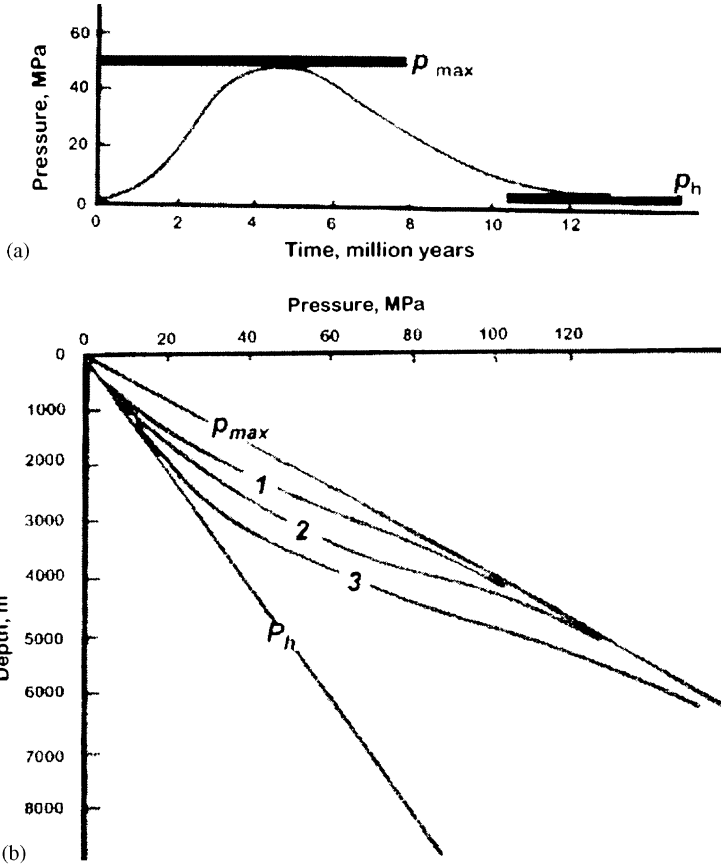

Fig. 11.37. Results of pore-fluid pressure simulation. (a) Variation in pore-fluid with time; (b) variation in pore-fluid pressure with depth, for three regions of the South Caspian Basin. p_h = hydrostatic pressure, p_{max} = total overburden (geostatic) pressure. (After Buryakovsky, 2001, p. 402.)

Using Eq. 11.106, it is possible to describe the dynamics of the pore-fluid pressure (Fig. 11.37a) and to forecast the pore pressure in the reservoir rocks and caprocks at various depths (Fig. 11.37b) for the various regions of the South Caspian petroleum province. It has been shown (Fig. 3.15) that hydrostatic pressure gradients in shales at the depth interval of 1,000–6,000 m (over 2,000 determinations by well-logging) range from 0.012 to 0.024 MPa/m with an average value of 0.018 MPa/m.

11.3.3.6. Simulation of oil/water mobility

The simulation of dynamic systems on using the methodology described above, gave rise to the mathematical model of changes in reservoir saturation during oil displacement by water.

In the course of oil displacement by water, water saturation S_w of the reservoir increases from the residual water saturation ($S_{w,1} = S_{w,r}$) to the value of the entire

pore volume minus the residual oil saturation $S_{w,2} = (1 - S_{o,r})$. A dynamic model $S_w = f(t)$ with a S_w range between $S_{w,r}$ and $(1 - S_{o,r})$ was constructed using Eq. 11.76 at $f(x) = x(1-x)$, where $x = S_w$. With the initial and final conditions taken into account, the solution of Eq. 11.76 is as follows:

$$S_w = [(1 - S_{o,r})S_{w,r} \exp((1 - S_{o,r})\varepsilon t)] / [(1 - S_{o,r}) - S_{w,r} + S_{w,r} \exp((1 - S_{o,r})\varepsilon t)] \quad (11.107)$$

where t is the duration of oil displacement by water. The change of water saturation versus time is shown in Fig. 11.38.

The above-described dynamic model allows one to achieve two goals:

- (1) To follow closely the changes in reservoir saturation occurring during oilfield development.
- (2) To apply the model for observation of the water invasion into the reservoir and of movement of the oil–water contact (based on well logs and oil and water production information).

The specific feature of the model is that it takes into consideration the so-called “technological” duration of the process of reservoir development. The model (Eq. 11.107), which describes the dynamics of water encroachment in oil-saturated reservoir in the process of oil production, can be changed into a model of lateral migration of oil (if the water is replaced by the oil) in “geologic” time scale.

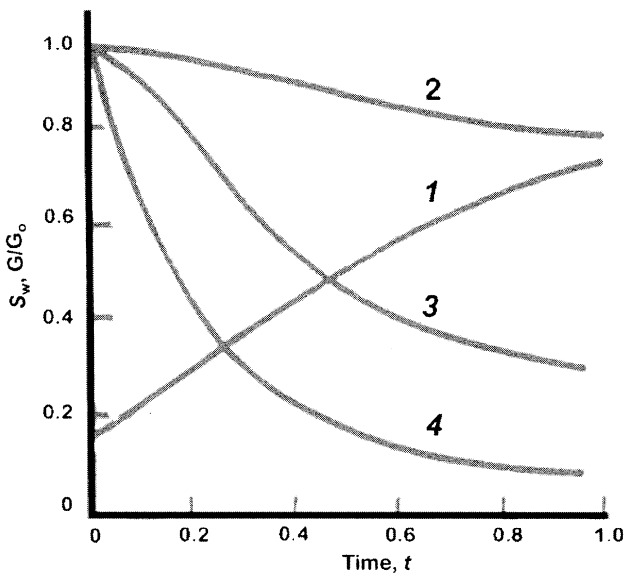

Fig. 11.38. Results of simulation of water saturations S_w vs time. (1) G = petrophysical parameter, G_o = initial value of G , 2 = acoustic transit time Δt , 3 = anisotropic true sensitivity R_{ta} , 4 = isotropic resistivity R_i . (After Buryakovskiy et al., 2001, p. 399.)

11.4. ALGORITHM OF ACCELERATED EXPLORATION FOR HYDROCARBON ACCUMULATIONS

The progress in the oil and gas industry is related closely to the acceleration of discovery rates, exploration, development, and production of hydrocarbon resources. This activity must be based on scientific information, which helps to predict subsurface conditions and properties of the oil- and gas-bearing formations. The use of mathematical methods and computers increase the scope of problems that can be solved on the basis of integrated geological, geophysical, geochemical, engineering, and commercial information. Mathematical methods using computer-aided processing of the available information accelerate the process of regional and local prediction of oil and gas potential and increase the reliability of geologic forecast, that, in general, increases the commercial and geologic efficiency of exploration, development, and production of oil and gas fields.

Exploration of mineral resources in spite of its commercial content and significant spending of time and investment may be considered as an actual industrial experiment resulted in changing the *a priori* probability of mineral deposit discovery. Exploration being essentially an informational process is profitably employed the information input, storage, and processing procedures beginning with experiment design (exploration operations including geophysical surveys and drilling the prospecting and exploratory wells) and ending with computerized geological–geophysical mapping, forecasting of exploration results, mineral resource assessment, and field-development engineering. Utilization of mathematical methods is the prolongation of exploration activity and is an effective factor of exploration acceleration. In the harsh and severe ambient and subsurface environments and under complex and rigorous technical, engineering, organizational, and financial conditions, such an approach increases the commercial efficiency of the mineral resources discovery, assessment, and utilization, as well as subsurface protection and conservation. Such situations generally occur while prospecting and exploring the sedimentary basins at great depths or while working in the offshore areas characterized by the scarce information on the reservoir geometry, composition, and type of fluid saturation.

To resolve this problem, the method of accelerated exploration and commercial estimation of hydrocarbon resources was proposed by Buryakovsky et al. (1990). This method resulted in trap identification and mapping, subdivision of stratigraphic sequences, reservoir delineation and structural description, reservoir rock and formation of fluid properties assessment, and estimation of initial in-place and recoverable hydrocarbon reserves.

CONCLUDING REMARKS

The oil and gas generation and accumulation processes are occurring (and occurred) in all sedimentary basins. The formation and preservation of hydrocarbon accumulations, however, required favorable environments.

The development of concepts of oil and gas generation continuously expanded with time. Instead of individual organic substances, the source organic matter is now

considered to be almost any carbon-containing organic matter. Temperature wise, instead of a narrow range of high-temperature petroleum is generated in a broad temperature range starting at ambient temperature. In terms of the energy source, the concepts shifted from the heat flow to any other energy source in the Earth's crust, including the surface energy of finely fragmented rocks and minerals. Instead of clay–shale deposits alone, the source facies now include a wide range of subaquatic deposits. In terms of duration, it changed from a narrow “window” or “phase” to a long and continuous process occurring in the Earth's crust at a variable speed.

The future is rather optimistic. In the onshore basins with discovered fields, at least 30–35% of the reserves remain undiscovered due to imperfection of current exploration and appraisal techniques. These reserves reside in the (1) lithologic traps, (2) traps with capillary and hydraulic barriers, (3) synclines or over the monoclines, (4) poor reservoirs, and (5) “critical state” accumulations. The technological advances will probably increase the estimated reserves further.

Presently, the sedimentary oil and gas basins, shelves, and continental slope areas are targets of an accelerated exploratory and appraisal efforts. There is not much hope to discover major hydrocarbon accumulations in the middle of the oceans. The potential of the continental slopes is also unknown. The potential of the Antarctica and its shelves are also not studied.

As the extent of our knowledge of a particular region increases, the efficiency declines, the fraction of large discoveries drops, and the structure of reserves becomes more complicated. At the same time, the number of (1) small fields, (2) the amount of their reserves, (3) the number of oilfields with difficult-to-produce oil, and (4) low-permeability reservoirs increased. The productivity of newly-completed wells became lower. More remote areas with harsher natural environment are being explored.

Practically all the giant fields in the World are currently under development and major producing formations are at a stage of declining production. In Russia, for example, most gas is produced from two giant West Siberia fields (Orenburg and Vuktyl fields). Plethora of small fields produce very small amount of oil.

Decline in the petroleum production results in the economic, political, and social complications. The issue of the scientific studies, especially the fundamental ones, is becoming acute. The fundamental studies, which are the mainstay of energy industry, are unfortunately decreasing. No technical progress can be achieved in the absence of scientific progress, and the modern society cannot function without the technical progress.

The current status and avenue of scientific studies is predicated on the extent of computerization. It covers analytical and measuring equipment, seismic and logging equipment, and acquisition, storage and processing of information. Broad application of Information Technology provides opportunities for integration of diverse technologies and modeling of the processes and targets. The computers are very important in the studies of fundamental problems.

N.A. Eremenko and
G.V. Chilingar

Appendix A

WETTABILITY AND CAPILLARITY

A.1. INTRODUCTION

The pore space of reservoir rock is filled with oil, gas, and/or water. The interfaces between fluids, and between fluids and solids, are the loci of many physical and chemical phenomena, including surface free energy, surface tension, adsorption, cohesion, adhesion, wettability, and capillarity.

The fundamental basis for explaining many interfacial phenomena is the fact that all molecules exert attractive forces on each other. These attractive forces, generally known as the *van der Waals forces*, are weak forces between molecules, which vary inversely as the sixth power of the intermolecular distance, and are due to momentary dipoles caused by fluctuations in the electronic configuration of the molecules. These forces oppose the molecular agitation (kinetic energy of the molecules that increases with increasing temperature) and cause contraction of the surface of a liquid due to the surface free energy. The surface area is reduced to a minimum, and for a given volume the minimum is a sphere. The tension at a liquid surface in contact with either air or its vapor is called the *surface tension*. The surface tension is equal to the surface energy.

In terms of molecular interaction, one should distinguish between the terms of “cohesion” and “adhesion:” the term “cohesion” is applied to the attractive forces between the like molecules, whereas “adhesion” is applied to forces between unlike molecules. The liquid that has the higher molecular interaction (higher adhesion) with the solid is the *wetting* liquid, whereas the liquid that has the lower molecular interaction (lower adhesion) with the solid is the *non-wetting* liquid.

When two immiscible liquids, such as oil and water, fill the pore space of reservoir rock, they compete for a place on the solid surface. In solving many production and reservoir engineering problems, it is very important to know which liquid (oil or water) wets the rock surfaces. The relative ability of water and oil to wet the rock is theoretically the same as the relative degree of adhesion between the two liquids and the reservoir rock. Because the pore throats and canals in the reservoir rock are mainly of capillary size (<0.5 mm), capillary phenomena help explain the behavior of fluids in the oil and gas reservoirs.

A.2. WETTABILITY

The manifestation of molecular interaction at the interface between three phases: solid, liquid, and gas (or another liquid not miscible with the first) is called the *wettability*. In the reservoir rock, the wettability is the appearance of molecular interaction of a liquid with the pore space surface, the magnitude and nature of which is related to the nature of the surface and geometry of the pore space.

The wettability is calculated on the basis of core sample weights measured at various testing modes. For example, the forced displacement of oil to S_{or} and water to S_{iw} may be conducted using a centrifuge or by mounting the core in fluid-flow equipment and pumping the displacing fluids into the core (see, e.g., Tiab and Donaldson, 2004, for details, pp. 371–373).

Wettability may be defined also as the ability of the liquid to “wet,” or spread over, a solid surface. Fig. A.1A shows a liquid wetting a solid surface, whereas Fig. A.1B shows the relationship between the liquid and solid when the liquid has little affinity for the solid. In Fig. A.1C, the liquid drop occupies an intermediate position. The fluid, which wets the surface more strongly, occupies the smaller pores and minute interstices in a rock.

The angle, which the liquid interface makes with the solid, is called the *contact angle*, θ . Usually, it is measured from the solid through the liquid phase (if the other phase is a gas) and through the water phase if oil and water are both present. In a capillary tube, shown in Fig. A.2A, the angle between the tube wall and the tangent to the curved interface (where it intersects the tube wall) is less than 90° . For a capillary depression, shown in Fig. A.2B, the contact angle is greater than 90° . In the case of no rise or depression, the angle is 90° (see Fig. A.2C)

Molecular interaction caused by the molecular property (intermolecular cohesive forces) of liquids is called the *interfacial tension*, θ . It has the dimensions of force per unit length (lb/ft or dyn/cm) or energy per unit area (erg/cm²). Interfacial tension causes the curved surface of the interface between two immiscible fluid phases (e.g., between the gas and liquid or between two liquids, as well as the interface between a liquid and a solid) to contract into the smallest possible area per unit of

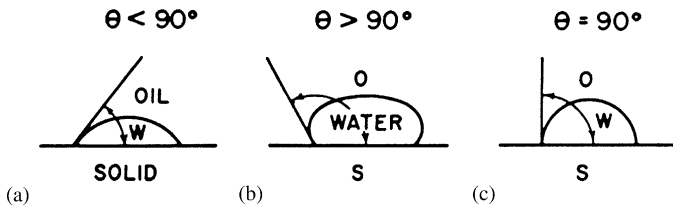

Fig. A.1. Different degrees of wetting of solid by liquid.

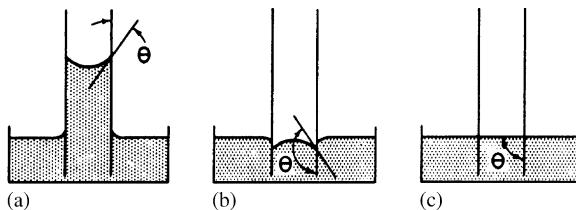

Fig. A.2. Behavior of various fluids in glass capillary tubes. (a)– water, (b)– mercury, and (c)– tetrahydronaphtalene (when glass is perfectly clean and liquid is pure).

volume. The difference in pressure across the interface between two immiscible fluid phases jointly occupying the interstices of a rock is known as the *capillary pressure*. The value of the capillary pressure (P_c in dyn/cm^2) depends on the interfacial tension and the curvature of the interfacial surface. Mathematical expression of the capillary pressure is as follow:

$$P_c = 4\sigma(\cos \theta)/d \quad (\text{A.1})$$

where P_c is the capillary pressure, σ is the interfacial tension, θ is the angle of contact of the liquid with the capillary tube wall, and d is the diameter of capillary tube.

A phenomenon associated with surface tension, which occurs in capillary tubes, is known as the *capillarity*, which is represented by the elevation (or depression) of liquid in the capillary tube.

The chief effect of capillary pressure is its control over the static distribution of the fluids within a non-producing reservoir. The static capillary pressure within the voids of a reservoir, which may be considered as a bundle of capillary tubes, is a function of the relative fluid saturation. The capillary pressure of a water–oil system may be plotted as a function of the water saturation, as shown in Fig. A.3.

If it is assumed that reservoir rocks are originally water-wet, the water is displaced by oil. Obviously, not all of the water is displaced, for all oil reservoirs contain varying amounts of interstitial water, even if only oil (or gas) is produced. The displaced water is called the free water to distinguish it from the thin layer of adsorbed water held to the mineral grains by capillary pressure. This water is called the *residual water* or the *irreducible water*, S_{iw} (see Fig. A.3).

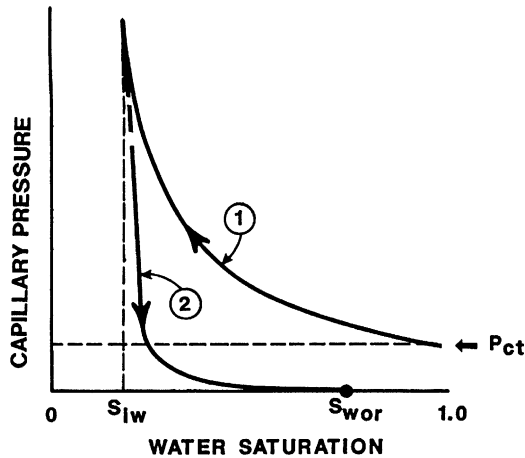

Fig. A.3. Typical method for plotting capillary pressure vs. saturation for a water-wet system (modified after Tiab and Donaldson, 2004, Fig. 5.9, p. 325). P_{ct} is the threshold pressure, S_{iw} is the irreducible water saturation, and S_{wor} is the residual oil saturation. 1 – Water is displaced from the core by oil. 2 – Oil is displaced from the core by water.

A.2.1. Interfacial Tension and Contact Angle

On considering an element of an interface having double curvature (R_1 and R_2), the sum of the force components normal to the element is equal to zero (see Fig. A.4). The pressure difference ($p_2 - p_1$) is balanced by the interfacial tension forces:

$$(p_2 - p_1)dydx = 2\sigma dy \sin \theta_2 + 2\sigma dx \sin \theta_1 \tag{A.2}$$

If the contact angles (θ_1 and θ_2) are small, then the following simplifications may be made:

$$\sin \theta_1 = dy/2R_1 \tag{A.3}$$

and

$$\sin \theta_2 = dx/2R_2 \tag{A.4}$$

Therefore, Eq. A.3 becomes

$$p_2 - p_1 = \sigma \left(\frac{1}{R_2} + \frac{1}{R_1} \right) \tag{A.5}$$

For a capillary tube (see Fig. A.5)

$$R_1 = R_2 = R \tag{A.6}$$

$$\cos \theta = d/2R \tag{A.7}$$

and

$$p_2 = p_1 + \gamma h \tag{A.8}$$

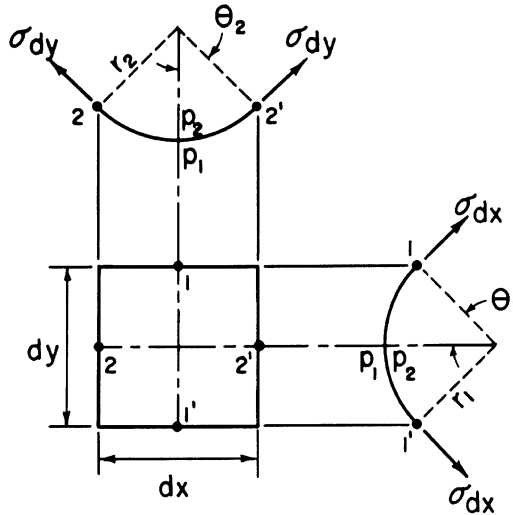

Fig. A.4. Surface tension forces acting on a small element on the surface having double curvature ($p_2 = p_1 + \gamma h$) (see Binder, 1962; Vennard, 1961). $r_1 = R_1$ and $r_2 = R_2$ (radii of curvature).

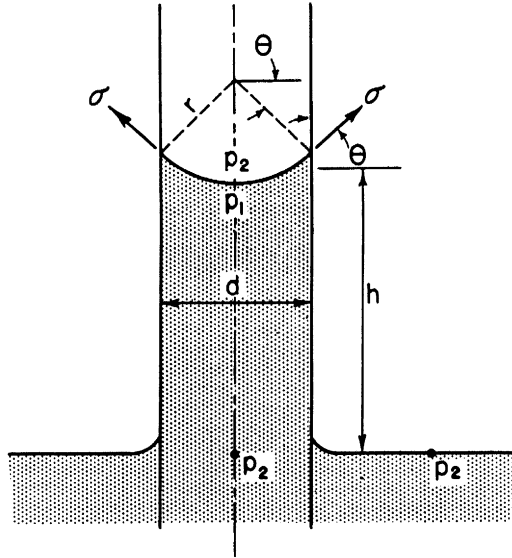

Fig. A.5. Rise of water in glass capillary tube (see Binder, 1962; Vennard, 1961). $r = R$ (radius of curvature).

where γ is the specific weight of fluid, d is the diameter of capillary tube, and h is the height of capillary rise. Thus, Eqs. A.5–A.8 may be combined to yield the following expression for capillary rise, h :

$$h = 4\sigma \cos \theta / \gamma d \quad (\text{A.9})$$

Eq. A.9 can also be derived on considering the equilibrium of vertical forces. The weight of fluid in the capillary tube, W , which is acting downward, is equal to

$$W = \pi d^2 h \gamma / 4 \quad (\text{A.10})$$

The vertical component of interfacial tension force acting upward is equal to

$$F_{\sigma\gamma} = \pi d \sigma \cos \theta \quad (\text{A.11})$$

Equating these two forces and solving for h gives rise to Eq. A.9.

In reference to Fig. A.6, the interfacial tension can be expressed as

$$\sigma_{ws} + \sigma_{wo} \cos \theta = \sigma_{so} \quad (\text{A.12})$$

where σ_{ws} , σ_{wo} , and σ_{so} are interfacial tensions at the phase boundaries of water–solid, water–oil, and solid–oil, respectively, or

$$\cos \theta = (\sigma_{so} - \sigma_{ws}) / \sigma_{wo} \quad (\text{A.13})$$

As shown in Fig. A.7A, when a solid is completely immersed in water phase, $\theta = 0^\circ$, $\cos \theta = +1$ and, consequently,

$$\sigma_{wo} = \sigma_{so} - \sigma_{ws} \quad (\text{A.14})$$

When half of the solid is wet by water, and the other half, by oil (Fig. A.7B),

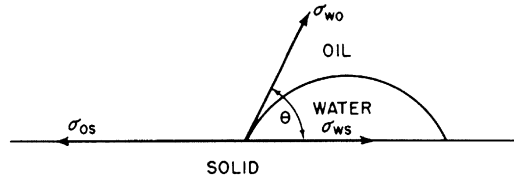

Fig. A.6. Shape of water drop resulting from interfacial tension forces.

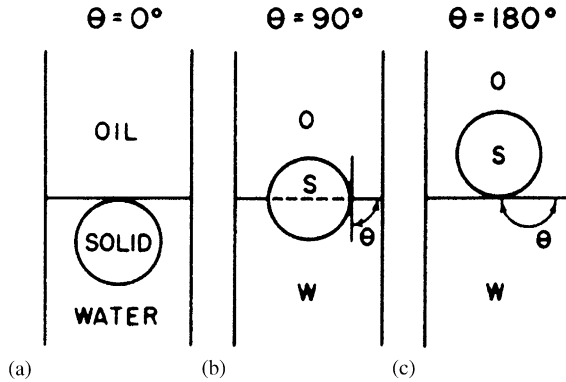

Fig. A.7. Illustration of 0°, 90°, and 180° contact angles.

$\theta = 90^\circ$ and $\cos \theta = 0$, and thus

$$\sigma_{so} = \sigma_{ws} \tag{A.15}$$

On the other hand, if the solid is completely wetted by oil (Fig. A.7C), $\theta = 180^\circ$, $\cos \theta = -1$, and

$$\sigma_{so} = \sigma_{ws} - \sigma_{wo} \tag{A.16}$$

If $\theta < 90^\circ$, the surfaces are called hydrophilic and when $\theta > 90^\circ$, they are called hydrophobic. An interfacial tension depressant lowers σ_{wo} , whereas a wetting agent lowers θ or increases $\cos \theta$. A decrease in σ_{wo} does not necessarily mean an increase in $\cos \theta$, or vice versa, because of the changes in σ_{so} and σ_{ws} .

If a rock is completely water-wet ($\theta = 0^\circ$), water will tend to envelop all of the grains and force all of the oil out into the middle of the pore channel. Even though some oil may still be trapped in this case, the recovery would be high. On the other hand, if all of the solid surfaces were completely oil-wet ($\theta = 180^\circ$), oil would tend to envelop all of the grains and force all of the water out into the center of the pore channel. In this extreme case, recovery would be very low by water drive. Many oil-wet reservoirs are known to exist.

In the usual case ($0^\circ < \theta < 180^\circ$), to improve waterflooding operations the contact angle θ should be changed from $> 90^\circ$ to $< 90^\circ$, through the use of surfactants. This would move the oil from the surface of the grains out into the center of the pore channels, where they would be produced more readily.

Contaminants or impurities may exist in either fluid phase or may be adsorbed on the solid surface. Even if present in minute quantities, they can and do change the contact angle from the value measured for pure system (see Marsden, 1968).

A.3. EFFECT OF CONTACT ANGLE AND INTERFACIAL TENSION ON MOVEMENT OF OIL

For an ideal system composed of pure liquids, the advancing contact angle should equal the receding angle. Because of the presence of impurities within the liquids, however, the advancing contact angle is greater in most systems. The advancing contact angle is the angle formed at the phase boundary when oil is displaced by water. It can be measured as follows: the crystal plate is covered by oil and then the water drop is advanced on it. The contact angle is the limiting angle with time after equilibrium has been established (see Fig. A.8). The contact angle formed when water is displaced by oil is called the receding angle (see Fig. A.9). The contact angles during movement of a water–oil interface in a cylindrical capillary, having a hydrophilic surface, are shown in Fig. A.10.

In as much as a reservoir is basically a complex system of interconnected capillaries of various sizes and shapes, an understanding of flow through capillaries is very important. In Fig. A.11, a simple two-branch capillary system is presented. If a pressure drop is applied, then the water will flow more readily through the large-diameter capillary than it will through the small-diameter one. Thus, a certain volume of oil may be trapped in the small capillary when water reaches the upstream fork. Poiseuille's law states that

$$q = \pi d^4 \Delta p_i / 128 \mu L \quad (\text{A.17})$$

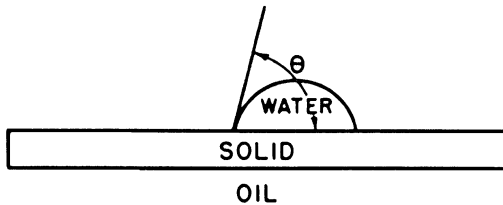

Fig. A.8. Contact angle: plate is first immersed in oil followed by the placement of water drop on top.

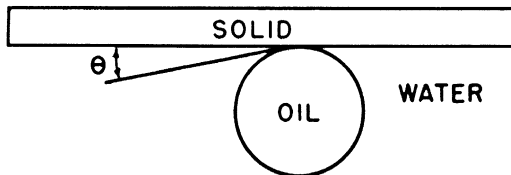

Fig. A.9. Contact angle: plate is first immersed in oil followed by the placement of water drop underneath.

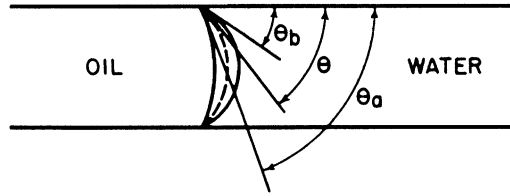

Fig. A.10. Changes in contact angle as a result of movement of water–oil interface. θ is the contact angle at static position, θ_a is the contact angle when oil is displaced by water (advancing angle), and θ_b is the contact angle when water is displaced by oil (receding angle).

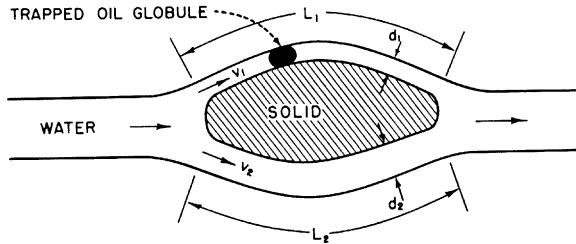

Fig. A.11. Flow through a two-branch capillary and trapping of oil in a small-diameter capillary.

and

$$v = q/A = d^2 \Delta p_t / 32 \mu L \quad (\text{A.18})$$

where q is the volumetric rate of flow (cm^3/sec), d is the diameter of capillary (cm), Δp_t is the total pressure drop (dyn/cm), A is the cross-sectional area (cm^2), μ is the viscosity (cP), L is the flow path length (cm), and v is the velocity (cm/s).

The total pressure drop, Δp_t , is equal to

$$\Delta p_t = \Delta p_i + P_c. \quad (\text{A.19})$$

where P_c is the capillary pressure (see Eq. A.1) and Δp_i is the applied pressure (dyn/cm^2). Solving for v in each capillary, by combining Eqs. A.1, A.18, and A.19 gives

$$v_1 = d_1^2 / 32 \mu_1 L_1 (\Delta p_i + 4\sigma \cos \theta / d_1) \quad (\text{A.20})$$

and

$$v_2 = d_2^2 / 32 \mu_2 L_2 (\Delta p_i + 4\sigma \cos \theta / d_2) \quad (\text{A.21})$$

Setting $L_1 = L_2$ and $\mu_1 = \mu_2$, and dividing Eq. A.20 by Eq. A.21 gives the following relationship:

$$v_1 / v_2 = (d_1^2 \Delta p_i + 4\sigma \cos \theta d_1) / (d_2^2 \Delta p_i + 4\sigma \cos \theta d_2) \quad (\text{A.22})$$

Therefore, when $\Delta p_i \gg P_c$,

$$v_1 / v_2 \approx d_1^2 / d_2^2 \quad (\text{A.23})$$

and when $\Delta p_i \ll P_c$,

$$v_1/v_2 \approx d_1/d_2 \quad (\text{A.24})$$

As shown in Fig. A.12, the sum of forces acting on the trapped oil globule may be expressed as

$$\sum F = F_1 + F_2 - F_3 \quad (\text{A.25})$$

where

$$\sum F = \pi d^2 \Delta p_t / 4 \quad (\text{A.26})$$

$$F_1 = \pi d^2 \Delta p_i / 4 \quad (\text{A.27})$$

$$F_2 = \pi d (4\sigma_a \cos \theta_a) \quad (\text{A.28})$$

and

$$F_3 = \pi d (4\sigma_b \cos \theta_b) \quad (\text{A.29})$$

Thus,

$$\Delta p_t = \Delta p_i + (4\sigma_a \cos \theta_a)/d - (4\sigma_b \cos \theta_b)/d \quad (\text{A.30})$$

Because the receding angle is usually lower than the advancing angle, the capillary pressure does not help, but hinders the flow. The term $(4\sigma_b \cos \theta_b)/d$ is usually greater than $(4\sigma_a \cos \theta_a)/d$ because $\theta_b < \theta_a$. If a surfactant was added at the left to reduce σ_a , Δp_t would become less and the oil globule may eventually move to the left as shown in Fig. A.12 when Δp_t becomes negative. The quantity of trapped oil is dependent upon the value of $\sigma \cos \theta$ at each end of the globule as well as upon Δp_i (imposed pressure drop).

Inasmuch as the contact angle depends upon the interfacial tensions, which, in turn, may be influenced by surfactants, these chemicals may alter recovery by altering both the contact angle and interfacial tension. As the oil is displaced by water, which wets the rock surface, capillary pressure is a driving force. If, on the other hand, water does not wet the rock surface, then the capillary pressure is a retarding force, which must be overcome.

The magnitude of capillary pressure in pores having a radius of around $15 \mu\text{m}$ is not large and, therefore, capillary pressure is not an important force during the movement of OWC, providing there is no mixing. The movement of oil

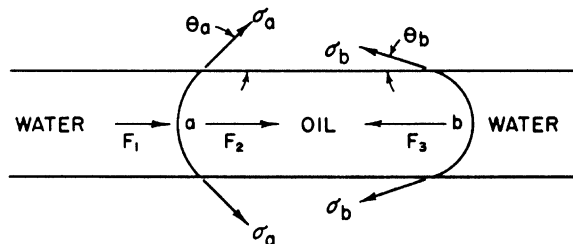

Fig. A.12. Forces acting on a trapped oil globule in a capillary.

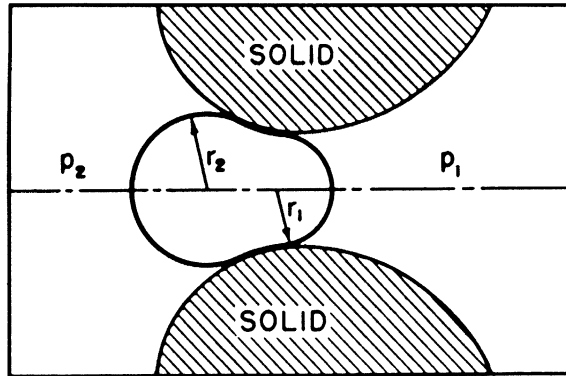

Fig. A.13. Movement of gas globule through a constriction (after Muravyov et al., 1958). r_1 and $r_2 = R_1$ and R_2 (radii of curvature).

and water in a reservoir, however, results in the formation of water–oil and gas–water–oil mixtures (see Muravyov et al., 1958). The amount of gas coming out of solution during migration is greater with increasing amount of dissolved active substances, with increasing surface area of porous medium (i.e., with decreasing permeability), and with decreasing temperature. As the oil–water–gas mixture moves through pores, the gas bubbles and water droplets are deformed on passing through constrictions (see Fig. A.13; see Muravyov et al., 1958). In order to move, the gas globule as shown in Fig. A.13 must overcome the capillary pressure equal to

$$\Delta p = p_1 - p_2 = 2\sigma \left(\frac{1}{R_2} - \frac{1}{R_1} \right) \quad (\text{A.31})$$

Although the Δp may be very small for a single globule, the cumulative resistance of many bubbles may be large (Jamin effect). Additional resistance to flow is created by the polymolecular layers of oriented molecules of surface-active components in the oil, which are adsorbed on the rock surface and may be quite thick (10^{-3} – 10^{-4} cm). At a constant pressure differential, the rate of oil filtration through porous media diminishes with time and is more pronounced in the case of higher content of polar compounds in the oil.

In water-wet carbonate rocks, vugs are “bad news” because during the waterflooding operations oil is trapped in the vugs. On the other hand, in oil-wet rocks, vugs are “good news” because water (non-wetting phase) will displace oil from the vugs. It should be remembered that the non-wetting phase preferably flows through larger pores.

A.3.1. Water block

The minimum pressure, p_{cwb} , required for oil to displace a globule of water stuck in a pore throat between the rock grains, providing the oil is the wetting phase, is

equal to

$$p_{\text{cwb}} = \sigma \left(\frac{1}{r_1} + \frac{1}{r_2} \right) \cos \theta \quad (\text{A.32})$$

where σ is the interfacial tension between the oil and water, r_1 and r_2 are the radii of capillary in two perpendicular directions, and θ is the contact angle.

The above equation can be derived from Eq. A.5:

$$p_1 - p_2 = \Delta p = \sigma \left(\frac{1}{R_1} + \frac{1}{R_2} \right) \quad (\text{A.33})$$

(where Δp is the pressure difference across the oil–water interface, and R_1 and R_2 are the curvatures of interface in two perpendicular directions), by substituting $r_1 / \cos \theta$ for R_1 and $r_2 / \cos \theta$ for R_2 .

A.4. BUOYANCY

Where the diameter of the gas bubble is less than that of the migration channel, the gas bubble/globule is able to float upward in the channel. In this case, the capillary pressure plays little or no part in the resistance to gas flow as the gas globule does not need to displace the water from the pore channel to migrate upward (a bubble is a small globule).

Fig. A.14 shows an example of gas bubble floating upward due to buoyancy force. For a Reynolds number, $N_R \leq 0.4$, the drag coefficient, $C_D = 24/N_R$ for a bubble of spherical form. Thus, for a laminar or viscous flow, the drag force, D , on the gas bubble is equal to

$$D = AC_D \rho (v^2) / 2 = (24\mu / \rho v d) \rho (v^2) / 2 (\pi d^2 / 4) = 3\mu v \pi d \quad (\text{A.34})$$

where A is the largest projected area (in ft²), ρ is the mass per unit volume (in slug/ft³), μ is the viscosity of the fluid (in lb-s/ft²) (or slug/ft s), v is the upward velocity of the bubble in ft/sec, and d is the diameter of the spherical gas bubble (in ft).

Inasmuch as the buoyant force, B , is acting upward, whereas the drag force, D , and the weight of the gas bubble, W_g , are acting down, $D + W_g = B$:

$$(\pi d^3 / 6) \gamma_w - (\pi d^3 / 6) \gamma_g = 3\mu v \pi d \quad (\text{A.35})$$

Solving for upward velocity of bubble, v ,

$$v = d^2 (\gamma_w - \gamma_g) / 18\mu_w \quad (\text{A.36})$$

Assuming a temperature of 25°C, a pressure of 20 kg/cm², a specific weight of methane gas of about 0.015 g/cm³, a specific weight of water of 1 g/cm³, a water viscosity at this conditions of approximately 10⁻² P, and a migrating gas bubble having the radius of 0.1 cm, the critical velocity is approximately equal to 0.22 cm/s.

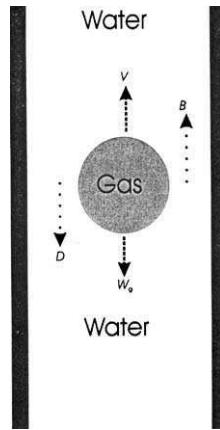

Fig. A.14. Gas bubble (or globule; bubble is smaller than globule) floating up through water in a channel where the diameter of the bubble/globule is smaller than that of the channel. W_g is the weight of bubble/globule, B is the buoyant force, D is the frictional drag force, and v is the upward velocity of the bubble/globule.

A.4.1. Sample problem

At laminar flow, calculate the rise velocity of a hydrocarbon gas bubble 0.1 mm in diameter through fresh water.

Given: gas bubble diameter, $d = 0.1 \text{ mm} \times (1 \text{ ft}/304.8 \text{ mm}) = 3.28 \times 10^{-4} \text{ ft}$; specific gravity of water, $SG = 0.998$; specific weight of water, $\gamma_w = (0.998 \times 62.4 \text{ lb}/\text{ft}^3) = 62.27 \text{ lb}/\text{ft}^3$; water viscosity, $\mu_w = 2.089 \times 10^{-5} \text{ lb}\cdot\text{s}/\text{ft}^2$ ($1 \text{ P} = 2.089 \times 10^{-3} \text{ lb}\cdot\text{s}/\text{ft}^2$); specific weight of hydrocarbon gas, $\gamma_g = 0.0422 \text{ lb}/\text{ft}^3$; specific weight of air at 59°F and $14.7 \text{ psia} = 0.07651 \text{ lb}/\text{ft}^3$; molecular weight of hydrocarbon gas = 16; molecular weight of air = 29.

The velocity of buoyant rise of the gas bubble is equal to

$$v = d^2(\gamma_w - \gamma_g)/18\mu_w = (3.28 \times 10^{-4})^2(62.27 - 0.0422)/18(2.089 \times 10^{-5}) = 1.78 \times 10^{-2} \text{ ft/s}$$

or 0.54 cm/s .

A.4.2. Gas Migration

The gas migration occurs when the upward force generated by the height of the gas column is greater than the capillary-force resistance of the rock through which the gas migrates. Some oil/gas reservoirs are composed of thin layers of alternating shale and sandstone. Only in gas-wet rocks, the gas migrates upward from layer to layer until it reaches the top of the water table, and then diffuses to the surface.

As the gas moves upward through the water in a capillary, several forces act on this gas column of height h : (1) weight of gas column (e.g., in lb) acting downward, $W_g = (\pi r^2 h)\gamma_g$, where r is the radius of capillary (e.g., in ft) and γ_g is the specific weight of gas (lb/ft^3); (2) upward force of water on gas, $B = (\pi r^2 h)\gamma_w$, where γ_w is the specific weight of water; and (3) capillary force, F_c , pulling the gas downward (in water-wet

rocks), $F_c = 2\pi r(\sigma_{wg} \cos \theta_{wg})$, where σ_{wg} is the water–gas interfacial tension and θ_{wg} is the water–gas–rock contact angle. Thus, $W_g + F_c = B$, or $(\pi r^2 h)\gamma_g + 2\pi r(\sigma_{wg} \cos \theta_{wg}) = (\pi r^2 h)\gamma_w$. Solving for h , one obtains

$$h = (2\sigma_{wg} \cos \theta_{wg})/r(\gamma_w - \gamma_g) = (2\sigma_{wg} \cos \theta_{wg})/r\Delta\gamma \quad (\text{A.37})$$

and in as much as $(2\sigma_{wg} \cos \theta_{wg})/r = P_c^{(wg)}$, which is the capillary pressure in the water–gas system:

$$h = P_c^{(wg)}/\Delta\gamma \quad (\text{A.38})$$

In gas-wet system (possibly some carbonates), the gas starts moving without reaching this minimum height because the capillary pressure aids the upward movement. (For analysis of oil-water system, see Chilingar et. al., 1972, pp. 355–356.)

The writers believe that petroleum geologists and engineers must be familiar with both the SI and FPS systems of weights and measures and be able to easily make necessary conversions.

This page intentionally left blank

Appendix B

PERMEABILITY

Permeability is the measure of the ability of a porous rock to transmit a fluid under the pressure gradient (differential pressure). The *absolute permeability* is the ability of a rock to conduct a fluid (gas, oil, or water) at 100% saturation with that fluid. *Effective/phase permeability* is the ability of a rock to conduct one fluid phase (gas, oil, or water) in the presence of other fluid phases. *Relative permeability* to a fluid is the ratio of effective/phase permeability at a given saturation to the permeability at 100% saturation (the absolute permeability). The terms $k_{ro}(k_o/k)$, $k_{rg}(k_g/k)$, and $k_{rw}(k_w/k)$ denote the relative permeability to oil, to gas, and to water, respectively (k is the absolute permeability, often the single-phase liquid permeability). The relative permeability is expressed in percent or as a fraction. It ranges from zero at a low saturation to 1 at a saturation of 100%.

Permeability is measured by an arbitrary unit called Darcy, which is named after Henry d'Arcy, a French engineer, who in 1856 devised a method of measuring the permeability of porous rocks. The permeability is equal to 1 Darcy if 1 cm³ of fluid per second flows through 1 cm² of cross-section of rock under a pressure gradient of 1 atm/cm, the fluid viscosity being 1 cP. Because most reservoir rocks have an average permeability considerably <1 Darcy, the usual measurement units are millidarcies (mD).

In the majority of formations there is a simultaneous existence of more than one phase: (1) oil and gas, (2) oil and water, or (3) oil, gas, and water. The concept of effective permeability implies that all but one phase are immobile. Inasmuch as a part of the effective pore space is occupied by another phase, a correction factor must be used. The magnitude of effective permeability depends on wettability, i.e., on whether (1) the immobile phase does not wet the solid surfaces of the rock and, therefore, occupies the central parts of the pores, or (2) the immobile phase wets the solid surfaces and thus tends to concentrate in smaller pores. The nature, distribution, and amount of immobile phase affects effective permeability.

The results of effective/phase permeability measurement are shown graphically in the triangular diagram, where the apex represents the 100% saturation point of the respective phase (oil, gas, or water). Contour lines of equal permeability to oil, gas, and water are drawn in order to evaluate the test results and characteristics of simultaneous multiphase fluid flow (Fig. B-1). Composition of three-phase flow through the porous media (after Leverett, 1941) is shown in Fig. B-2.

The diagram of relative permeability to oil and to water versus the oil and water saturation is constructed and data points for the relative phase permeability to oil and water in the presence of gas phase are depicted on the diagram. Examples of curves of relative permeability to oil and to water vs. water saturation are shown in Figs. B-3–B-5.

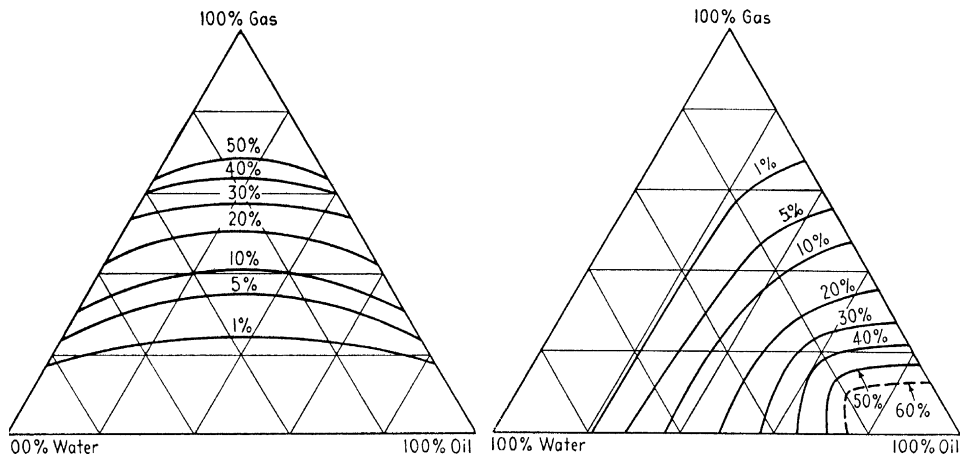
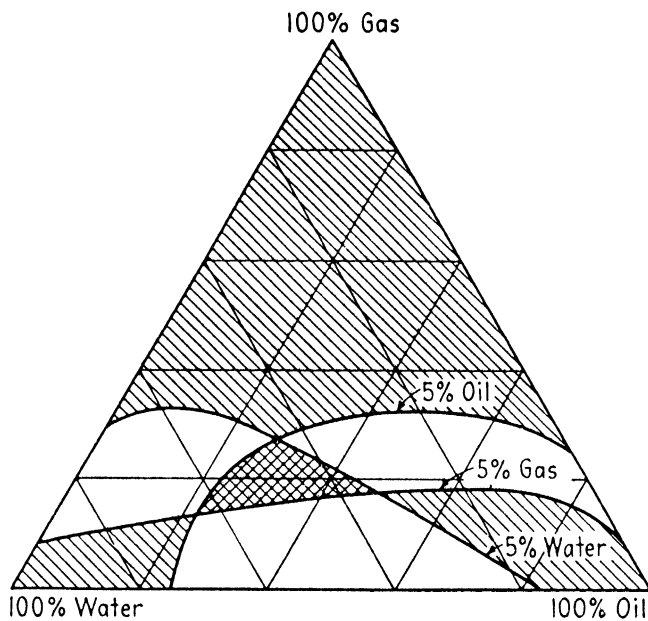

Fig. B-1. Triangle diagrams of ternary mixtures (water, oil, and gas) with lines of equal relative permeability (in %): (a) to gas (as a function of water and oil saturation), (b) to oil (as a function of gas and water saturation) (after Leverett, 1940; courtesy of AIME).



Legend



-  Essentially one phase flowing
-  Essentially two phases flowing
-  Appreciable flow of all three phases

Fig. B-2. Composition of a three-phase flow through the porous media (after Leverett and Lewis, 1940; courtesy of AIME).

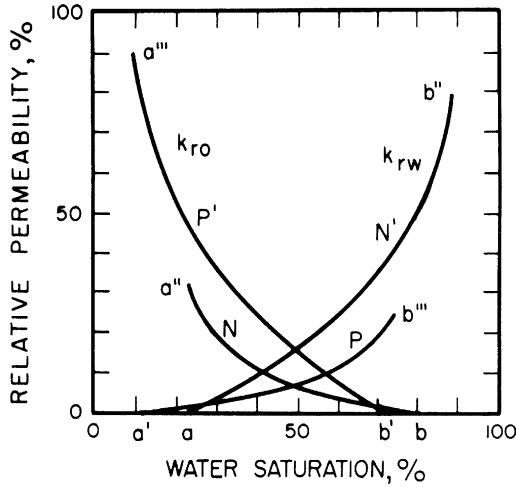

Fig. B-3. Relative permeability curves for polar and non-polar oil. Curves P and P' are for polar oil, whereas curves N and N' are for non-polar oil (after Babalyan, 1956, p. 145).

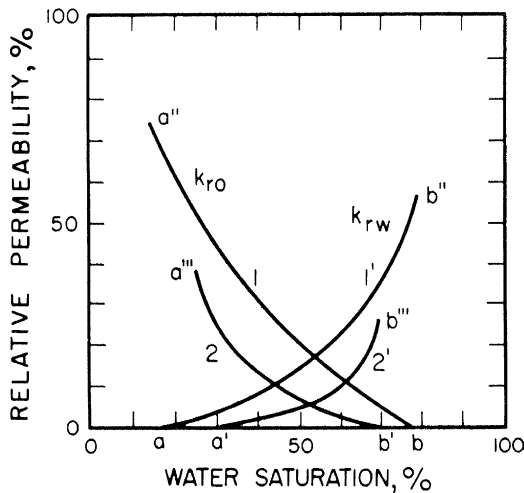

Fig. B-4. Relative permeabilities to oil and to water for polar oil + alkaline water (curves 1 and 1') and for polar oil + hard water (curves 2 and 2') (after Babalyan, 1956, p. 148).

In waterflooding projects or in natural water-drive pools, the relative permeabilities to oil and to water are of great importance. Where water and oil flow together, the relative permeabilities are affected by many factors, which include:

- (1) relative dispersion of one phase in the other,
- (2) time of contact with pore walls,
- (3) amount of polar substances in the oil,
- (4) degree of hardness of water,

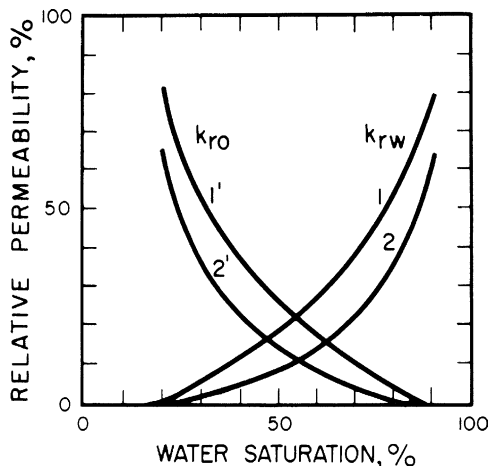

Fig. B-5. Relative permeability curves for non-polar oil with alkaline water (curves 1 and 1') and for non-polar oil + hard water (curves 2 and 2') (after Babalyan, 1956, p. 145).

- (5) relative amount of carbonate material in porous medium, and
 (6) temperature.

Based on the laboratory experiments (Sinnokrot and Chilingar, 1961), the relative permeability to the continuous phase (dispersion medium) is greater than the relative permeability to the discontinuous (dispersed, internal) phase. With increasing degree of dispersion, the relative permeability increases for both continuous and discontinuous phases. The degree of dispersion increases with decreasing interfacial tension and increasing time of coalescence of dispersed-phase droplets.

Sticking (attachment) of the dispersed phase to solid surface depends on (1) interfacial tension, (2) angle of contact, (3) time necessary for the coalescence of droplets and lenses of mobile part of a dispersed phase with immobile part, and (4) thickness of dispersion medium (continuous phase) layer attached to the solid surface. The relative permeability of the dispersed phase decreases if its droplets stick to the solid surfaces. The thickness of water film on solid surfaces is decreased in the presence of surface-active substances, which adsorb on the surfaces. In the case of alkaline water, which contains certain amount of salts of organic acids (soaps), adsorbed layer (film) is thinner than in the case of hard or distilled water.

At low water saturation, water is present as a dispersed phase. The intensity of its transition from a dispersed phase into a dispersion medium (continuous medium) is determined by the intensity of coalescence of water droplets and intensity of their sticking (attachment) to solid surfaces. The water saturation at which water changes from a dispersed phase into a continuous phase decreases with decreasing time of coalescence and sticking of water droplets to solid surfaces.

With increasing concentration of polar substances in the oil, the cumulative water production decreases. The change in oil production rate upon increasing the concentration of polar substances in oil is quite rapid initially; then it slows down and eventually stabilizes when the polarity of oil reaches a certain limit. As shown in

Fig. B-3, the critical saturation for water decreases (point a moves to a') and that for oil increases (point b moves to b') with increasing concentration of polar substances in the oil. With decreasing concentration of polar substances in oil, the relative permeability to water sharply increases (point b''' moves to b''), whereas that to oil decreases (point a''' moves to a''). This is mainly due to the fact that attraction of non-polar oil to solid surfaces is negligible and that the mobile oil presents less resistance to flow of water than does the immobile oil.

According to Babalyan (1956), in the case of polar oil the water, and oil production is greater when the water is alkaline than when it is hard. This is due to the change in the critical saturation of both phases (Fig. B-4). As shown in Fig. B-4, the relative permeability curves of oil + alkaline water lie above those of oil + hard water, because the following is true in the case of alkaline waters: (1) low interfacial tension between oil and water, (2) low values of contact angle, (3) slow coalescence of oil droplets in water, and (4) greater degree of dispersion of oil in water. In the case of hard water, on the other hand, the oil becomes a dispersed phase at higher water saturation in a porous medium than in the case of alkaline waters. The intensity of the transformation of oil into a dispersed phase is greater in the alkaline than in hard waters.

In the case of non-polar oil, the attachment of oil to solid surfaces is negligible in the presence of both alkaline and hard waters. When non-polar oil flows with either alkaline or hard water, there is no change in critical saturations and hence the recovery of oil and water is the same in each case. The relative permeability curves with alkaline water, however, lie above those with hard water (Fig. B-5).

Some of the controversial aspects of the above discussion will be resolved by future research.

For details on the relative permeability of carbonate reservoirs see Honarpour et al. (1992).

This page intentionally left blank

*Appendix C***GLOSSARY*****A**

Abandon	To cease efforts to test dry hole or to produce oil or gas from a well when it becomes unprofitable and to place the cement plug(s) in the borehole to prevent migration of fluids between the different formations penetrated by the borehole. See: Plug and abandon (P&A)
Abiogenic	Products (minerals, sediments, or rocks) resulting from inorganic processes of formation. Cf: Biogenic.
Abnormal pressure	Pressure exceeding or falling below the normal pressure to be expected at a given depth.
Absolute permeability	A measure of the ability of a single-phase fluid (such as water, gas, or oil) to flow through a rock formation when the formation is totally filled (saturated) with this fluid.
Accretion	Vertical buildup or lateral extension of deposits as a consequence of sedimentation or biotic activities.
Accuracy	Closeness to the true value or to value accepted as being true; the degree of perfection attained in a measurement, computation, or estimate, or degree of conformity to some recognized standard value (such as conventional unit of measure, an exact mathematical value, or a survey observation determined by refined methods). Accuracy related to the quality of a result, as distinguished from precision.
Acidizing	The introduction of acid (hydrochloric, formic, and acetic, for carbonates; and hydrofluoric for sandstones) into a formation to dissolve rocks, thus opening new and widening old passageways for fluids to flow through. See also: Fracture acidizing, Matrix acidizing.
Acoustic (sonic) log	Measurement of porosity, lithology, and cement bonding by the use of sonic waves.

*Also see Chilingarian et al., 1986, 1996.

Aerobic	Said of an organism that can live only in the presence of free oxygen; also said of its activities. Cf: Anaerobic, Anoxic.
Aggradation	Vertical accumulation of deposits as a consequence of sedimentation or biotic activities. Cf: Degradation.
Air drilling	Use of compressed air instead of liquid as the circulation medium in rotary drilling. See also: Gas drilling.
Algorithm	A set of rules which specify a sequence of actions to be taken to solve a mathematical problem. It frequently involves repetition of an action.
Alkali	Any strongly basic substance, such as a hydroxide or carbonate of an alkali metal (e.g., sodium, potassium). Plural: Alkalis. Adj: Alkaline.
Alkaline (soft) water	Water containing not more than 60 ppm (60 mg/l) of hardness-forming constituents (calcium and magnesium) expressed as CaCO ₃ equivalent. Cf: Hard water.
Alkanes (or paraffins)	Methane series derived from petroleum, with carbon atoms arranged in a straight chain. It includes methane, ethane, propane, butane, pentane, hexane, and octane (C _n H _{2n+2}).
Alkenes	See: Olefins.
Alkylation	The reaction of alkenes or olefins with branched-chain alkane to form a branched, paraffinic hydrocarbon with high anti-knock qualities.
Allochem	Carbonate particle of either skeletal or non-skeletal origin.
Allochthonous	Sediments or rocks formed elsewhere than where they are ultimately deposited; of foreign or introduced origin. Syn: Alloigenous.
Alluvial	Pertaining to or composed of alluvium, or deposited by a stream or running water.
Alluvial fan	An outspread, gently sloping mass of alluvium deposited by a stream, especially in an arid or semiarid region where a stream issues from a narrow canyon onto a plain or valley floor.
Alluvium	A general term for detrital deposits made by streams on river beds, flood plains, and alluvial fans; especially a deposit of silt or silty clay laid down during the time of flood.
Anaerobic	Said of an organism that can live in the absence of free oxygen; also said of its activities. Cf: Aerobic.
Analogy	Likeness in form of function but not in origin.

Analysis of covariance	The partition of the total variation in a set of observations into components corresponding to differences between and within sub-classifications of the data, after adjustment for the effect of other, possibly related, variables (covariates).
Analysis of variance (ANOVA)	A statistical technique for simultaneously partitioning the total variance of a set of the data into components which can be attributed to different sources of variation, and which can be used to test for differences among several samples.
Anisotropic medium	A medium whose physical properties vary in different directions. Cf: Isotropic medium.
Annular space	Space between the outside of the casing and the wellbore.
API Gravity	The standard method of expressing the specific weight of oils: $^{\circ}\text{API} = 141.5/\text{SG} - 131.5$, where SG is the specific gravity of oil at 60°F compared with water at 60°F.
Aquiclude	A body of relatively impermeable rock functioning as an upper or lower boundary of an aquifer and does not transmit water. Cf: Aquifer.
Aquifer	A permeable reservoir or portion of reservoir containing formation water or groundwater. Cf: Aquiclude.
Argillaceous	Containing clay minerals as impurities in carbonate, siliciclastic, or evaporitic sediments.
Aromatics	Group of cyclic hydrocarbons found in oils. Contain a benzene ring nucleus in their structure, with a general formula $\text{C}_n\text{H}_{2n-6}$.
Artificial lift	Any mechanism, other than natural, that lifts fluid from the wellbore to the surface.
Asphalt	Black to dark-brown solid or semisolid bitumens, which gradually liquify when heated. Composed principally of carbon and hydrogen, but contain appreciable quantities of nitrogen, sulfur, and oxygen; largely soluble in carbon disulfide.
Asphaltenes	Any of the solid, amorphous, black to dark-brown dissolved or dispersed constituents of crude oils and other bitumens, which are soluble in carbon disulfide. They consist of carbon, hydrogen, and some nitrogen and oxygen, hold most of inorganic constituents of bitumens.
Atoll	A ring-shaped reef, circular or elliptical or horseshoe-shaped, generally encircling an interior lagoon, and surrounded by deeper water.

Authigenic	Formed or generated in place; specifically said of minerals that have precipitated in place or which have replaced other minerals or particles in various diagenetic environments.
Autochthonous	Said of sediments or rocks that have accumulated in place. Cf: Allochthonous, Alloigenous. Syn: Authigenous.
B	
Backstepping	Referring to carbonate platforms that are being eroded or tectonically drowned such that their areal dimensions are progressively reduced in a landward direction.
Bafflestone	Reef rock that has accumulated as a result of the trapping or baffling of sediments amidst in-place organic framework.
Ball sealers	Rubber balls dropped into a wellbore to plug perforations.
Bank	Limestone deposits consisting of skeletal matter formed by in-place organisms or sediments deposited generally in shallow water; in both cases the deposit may be surrounded by deeper water.
Barefoot	Well completed without casing.
Barite	A mineral often used as a component of drilling mud (or fluid) to add weight: barium sulfate (BaSO_4), $\text{SG} \approx 4.3$. Syn: Heavy spar.
Barrel	A unit of petroleum liquid measure equal to 42 gallons, US.
Barrier reef	Long, linear reef oriented parallel to shoreline and separated from it at some distance by a lagoon of considerable depth and width; generally occur along the margins of shallow-water platforms, and pass seaward into deeper-water environments.
Basin	(a) A depressed area with no surface outlet. (b) A low area in the Earth's crust, of tectonic origin, in which sediments have been accumulated.
Benzene	An aromatic hydrocarbon (C_6H_6) found in petroleum. Used as solvent for petroleum products. Used as synonym for gasoline in many European countries.
Bindstone	Reef rock that has accumulated as a result of the presence of tabular or lamellar fossils that encrusted or otherwise bound sediments during deposition. Partial syn: Boundstone, Biolithite.

Bioclastic	Skeletal-derived sediments. Syn: Biogenic, Skeletal-organic.
Bioerosion	Removal of generally consolidated sediments by the boring, scraping, chewing, and rasping activities of organisms.
Biogenic	Sediments or rocks, or mineral deposits whose origin is related to organic activity. Syn: Organic.
Bioherm	Mass of rock with varying amounts of topographic relief above sea floor that has been constructed by organisms.
Biolithite	General term for reef rocks that have accumulated as a result of the activity of organisms. Partial syn: Boundstone.
Biostrome	Bedded and widely extensive, or broadly lenticular, blanket-like mass of rock constructed by organisms.
Biota	All organisms that are living or have lived in an area, including animals and plants.
Bioturbation	The disruption of sedimentary strata and included sedimentary/biotic structures by the burrowing or grazing activities of organisms. Syn: Burrow mottling.
Bit	The rock-cutting tool attached at the working end of the drilling string. Syn: Drill (or drilling) bit.
Bitumen	A generic term for natural, inflammable substances that are composed of a mixture of hydrocarbons that are substantially free of oxygenated bodies.
Block diagram	An illustration, in which parts of machine or a process are represented by blocks or similar symbols, connected by straight lines or arrows. Syn: Flowchart.
Blowout	Blowing out of gas and fluids when excessive well pressure exceeds the pressure of the drilling fluid head.
Blowout preventer, BOP	Device consisting of a series of hydraulically controlled rams and inflatable bags to prevent the blowout of a well.
Bottom fraction	Heavier components of petroleum, which remain after the lighter ends have been removed (distilled out).
Boundstone	General term for reef rock that has accumulated as a result of the activity of organisms; or non-reef rock that has accumulated as a result of extensive syndepositional marine lithification.
Bound water	The thin layer of water, which adheres to the surface of shales and is not producible.

Brecciation	Disruption of strata, and development of fitted clasts separated by fractures or of chaotic clasts with or without matrix, formed as a result of tectonism, carbonate dissolution and collapse, or evaporite dissolution and collapse.
Bridge plug	A mechanical device used to “seal-off” the wellbore below the point where it is set.
BS	Basic sediment
BS&W	Basic sediment and water (often found at the bottom of tanks).
Buildup	General term for reef accumulation.
C	
Cable lift	A device that uses a cable, often from a tower, instead of a walking beam to lift the sucker rods.
Calcite/aragonite compensation depth	Depth in the sea below which the rate of calcite or aragonite dissolution exceeds their rates of deposition.
Caliche	Authigenic deposit of calcium carbonate, generally low-magnesium calcite, that forms at the expense of (i.e., replacing) preexisting sediments, soils, or rocks. Syn: Soilstone crust, Calcrete.
Calcification	Term describing the process of calcite or calcrete formation.
Caliper log	Determination of the inside diameter of a wellbore or casing
Capillarity	The action by which a fluid, such as water, is drawn up (or depressed) in small interstices or tubes as a result of surface tension. Syn: Capillary action.
Capillary	The minute openings between rock particles through which fluids are drawn.
Capillary action	The upward and outward movement of fluids through the porous rock as a direct result of surface properties of rock.
Caprock	An impervious body of a rock that forms a vertical seal against hydrocarbon migration. In a salt dome, an impervious body of anhydrite and gypsum, with minor calcite and sulfur, which overlies the top of the salt body, or plug. It probably results from accumulation of the less soluble minerals of the salt body during leaching of its top in the course of its ascent.
Carbonate rock	A rock consisting chiefly of carbonate minerals, such as limestone, dolomite, or carbonatite; especially a

	sedimentary rock composed of more than 50% (by wt) of carbonate minerals.
Carbonates	Group of minerals found mostly in limestones and dolomites. Calcite (CaCO_3) is the most abundant and most important. Aragonite has the same formula as calcite but it is less stable; and dolomite contains magnesium, $\text{CaMg}(\text{CO}_3)_2$. Often used as syn. for carbonate rocks.
Carbon dioxide injection	Compressed CO_2 is injected into the formation to supply energy to push the oil toward the producing wells and also to improve recovery by mixing with both the oil and water.
Casing	Pipe used to keep the wellbore walls from collapsing and to seal the borehole to prevent fluids outside the well from moving from one portion of the well to another (i.e., crossflow).
Catagenesis	Term applied to changes in existing sediments, or most commonly, rocks during deep burial at elevated temperatures and pressures short of metamorphism. Adj: Catagenetic. Syn: Mesogenesis, Epigenesis.
Catalysis	Process in which the chemical reaction rate is affected by the introduction of another substance (catalyst).
Cation-exchange capacity (CEC)	The total amount of exchangeable cations that a particular substance can adsorb at a given pH. Exchangeable cations are held mainly on the surface of clay minerals, and are measured in milligram-equivalents per 100 g of the substance.
Caustic injection	Adding caustic to the water being injected to improve oil recovery by forming oil-water emulsions that help plug-off the larger pore channels, giving a more even push to oil in moving it toward the producing wells. Also reduces interfacial tension and increases the relative permeability to oil.
Caustobiolith	A combustible organic rock, usually of plant origin.
Cellar	Area dug out beneath the drilling platform to allow room for installation of blowout preventer (BOP).
Cement	Naturally occurring (biogenic or abiogenic) precipitate of mineral material, usually calcite, aragonite, or dolomite in sedimentary rocks, that binds particles together into a lithified framework.
Cementation	Process by which sedimentary rock particles or fragments are cemented together after deposition. Partial syn: Consolidation.

Cementing	Pumping of the cement slurry down the casing and then back up the annular space between the casing and the borehole.
Cement slurry	A mixture of cement and water in a liquid form which is pumped behind the casing. The slurry is allowed to set until it hardens.
Centralizer	Device fitted around the outside of casing as it is lowered down in the borehole to keep cement in the hole, to achieve a good cement job.
Chalk	Carbonate rock of low-magnesian calcite composition consisting dominantly of the remains of coccoliths and coccospheres.
Chlorite	A group of minerals that are related in structure and composition to the micas. They are hydrated silicates and have general formula $(\text{Mg,Fe})_5\text{Al}(\text{AlSi}_3)\text{O}_{10}$; green, soft, and platy.
Choke	A device that restricts the flow in flowline or through the orifice, and causes a pressure drop or reduced flow rate. It provides precise control of wellhead flow rates in surface production applications involving oil and gas and in enhanced recovery.
Christmas tree	Array of valves, pipes, and fittings placed at the top of the well, on the surface.
Circulation system	Portion of the rotary drilling system, which circulates the drilling fluid (mud).
Circumgranular	Cement which completely lines the pores in a rock.
Clarke	The average abundance of a chemical element in the Earth's crust. It is named in honor of Frank W. Clarke (1847–1931), a Chief Chemist of the US Geological Survey from 1884 to 1925.
Clastic	Term used in reference to particles (carbonate, siliciclastic, or other mineralogies) that commonly are transported by fluids.
Claystone	A compacted, non-fissile, fine-grained, sedimentary rock composed predominantly of clay-sized particles. See: Mudstone.
Cluster analysis	A statistical method of classifying observations into homogenous subsets based on their mutual similarities and hierarchical relationships.
Coated grain	Carbonate particle consisting of nuclear fragment surrounded by a cortex of chemically precipitated carbonate (e.g., ooids, pisoliths) or cortex composed of organic encrustation (e.g., oncolites, rhodolites).
Coccolith	A button-like plate composed of calcium carbonate, generally about 3 μm in diameter, a number of which

	compose the outer skeletal remains of coccospheres (skeletons of marine, planktonic protists).
Coefficient of correlation	A dimensionless quantity measuring the degree of linear association between two variables and taking values in the range from -1 to $+1$: value of -1 indicates a perfect negative linear relationship; $+1$, a perfect positive relationship; 0 denotes the absence of relationship. Symbol: r .
Coefficient of determination	A measure of the proportion of each other's variability that two variables share; the squared coefficient of correlation. Symbol: r^2 .
Coefficient of variation	A dimensionless quantity measuring the relative dispersion of a set of observations, calculated as the ratio of the standard deviation to the mean of the data values (sometimes as a percentage). Syn: Coefficient of variability.
Collapse breccia	Sedimentary breccia formed as a result of collapse of indurated strata due to dissolution of underlying strata, or commonly, cave-roof collapse.
Combination drive	Two or three natural drives moving the reservoir fluids toward the wellbore.
Compaction	Reduction in bulk volume and/or thickness of a sedimentary deposit resulting from either physical processes of grain readjustment (closed packing) in response to an increased weight of overburden (mechanical compaction), or chemical processes such as dissolution, grain interpenetration, and stylolitization (chemical compaction).
Completion	Finishing a well. Installation of necessary equipment to produce a well. Includes placing the casing, cementing and perforation opposite the productive zone.
Composite sample	Oil sample composed of equal portions of samples obtained from two or more points in the tank.
Composite grain	Aggregate carbonate grain composed of discrete particles bound together by cement or organic mucilage.
Condensate	Liquid hydrocarbons, generally clear or pale straw-colored and of high API gravity (above 60°), that are produced with wet gas. Syn: Distillate, Natural gasoline.
Conduction log	Measurement of the formation electric conductivity.
Conductor	Casing pipe in a wellbore attached to the BOP.
Confidence level [stat]	The probability (prescribed in advance and expressed as decimals or percentage) that true value of an

	unknown parameter (e.g., mean value of probability distribution) will be in the confidence interval.
	Confidence level supplements the level of significance to 1 or 100% (often this probability is set at 0.95 or 95%). Syn: Level of confidence.
Confidence limits [stat]	Either the upper or the lower value between which an actual measurement or parameter will fall with a stated probability (i.e., confidence level). An interval between confidence limits is referred to as the confidence interval.
Connate water	Water ultimately of marine origin that has been entrapped in sediment pores after its burial, and which has been out of contact with the atmosphere for an appreciable period of geologic time. Cf: Meteoritic water.
Consolidation	Any process (including the deposition of cement) that changes loose sediment to a coherent rock. Syn: Lithification.
Contact angle	The angle which the oil–water interface makes with the solid (rock). Usually, it is measured from the solid through the liquid phase (if the other phase is a gas), and through the water phase if oil and water are both present, to the oil–water interface.
Continental slope	The part of continental margin that is located between the continental shelf and continental rise (or oceanic trench). It is characterized by relatively steep slope of 3–6°.
Contour map	A map with continuous lines connecting data points of equal value, such as elevation, formation thickness, rock porosity, etc.
Core	A cylindrical sample of the rock taken from the well during drilling operations.
Core sampling	Taking a sample of geological strata for examination. Syn: Coring.
Correlation	The intensity of association or interdependence between two or among several variables, e.g., a tendency for variation in one variable to be accompanied by linear variation in another.
Correlation ellipse	An ellipse outlying correlated data points within the given confidence level. Syn: Ellipse of correlation.
Corrosion	Chemical reaction (mainly loss of electrons) that oxidize metals, e.g., $\text{Fe} \rightarrow \text{Fe}^{2+} + 2e^{-}$.
Corrosion inhibitor	Chemicals added to minimize or prevent corrosion of metals.

Covariance	A measure of the association between two variables x and y calculated as the arithmetical mean or the expected mean value of the product of the deviation of two variables from their respective mean values. Symbol: $\text{cov}(x, y)$.
Critical point	A point at which one phase cannot be distinguished from another and the material cannot be condensed regardless of the amount of pressure applied. There is no volume change when a liquid is vaporized at the critical point (at critical temperature and critical pressure).
Critical velocity	A velocity at the transitional point between laminar and turbulent types of fluid flow. This point occurs in the transitional range of Reynolds numbers of approximately 2,000–3,000.
Cross-stratification	Layers or laminae of sedimentary rock deposited at angles to the horizontal (not exceeding the angle of repose in air or water) as a normal consequence of transport by air or water. Syn: Cross-bedding.
Crown block	Pulley installed at the top of the drilling rig, which raises and lowers the drillstring.
Crude oil	Petroleum as it is produced from the formation. The two categories of crude oils are distinguished: (a) heavy crude — thick (sticky) oil with an °API gravity $< 17^\circ$, and (b) light crude — thin (light) oil with an °API gravity $> 25^\circ$.
Cryptalgal	Term used in reference to a presumed algal or cyanobacterial origin of certain carbonate rock.
Cryptocrystalline	Term used in reference to crystal components (e.g., cement or architectural elements of shells) of very fine size, generally not resolvable without the use of at least a petrographic microscope; also said of a rock with such texture. Syn: Microcrystalline.
Crystal silt	Internal sediments found in cavities in rocks, composed of silt-size particles of crystals; generally form as a result of partial dissolution of host rock/sediment or boring by organisms.
Cumulative distribution function [stat]	A function giving the probability that a corresponding continuous random variable takes a value less than or equal to the argument of the function.
Cumulative frequency distribution [stat]	A curve drawn to represent the percentage of occurrences of a number of observations of a variable less and greater than any given value for an entire sample. Syn: Cumulative curve.

Cuttings	Rock chips or fragments produced by drilling and brought to the surface. Syn: Drill cuttings.
Cyanobacteria	Biological/geological term for blue-green algae (cyanophytes), the association of blue-green algae and bacteria, or the bacterial affinity of blue-green algae.
Cyclic sedimentation	Sedimentation involving a vertical repetition of rock types representative of distinct depositional environments. Syn: Rhythmic sedimentation.
Cycloparaffins	Group of saturated homocyclic hydrocarbons having the formula C_nH_{2n} . Syn: Naphthene.

D

Dedolomite	Dolomite that has been replaced by calcite wherein the crystal form of the predecessor has been preserved.
Dedolomitization	Process of replacement of dolomite by calcite with preservation of dolomite crystal form.
Deflation	Removal of the loose, dry sediment by wind action.
Deflection	A change in the angle of a wellbore. In directional drilling, it is measured in degrees from the vertical.
Degrees of freedom	The capability of variation in a system. The number of degrees of freedom is determined as the number of independent variables defining the state of a system.
Dehydration	The removal of water or water vapor from gas or oil.
Delta	The nearly flat alluvial tract of land at the mouth of a river, commonly forming a triangular or fan-shaped plain resembling the Greek letter "delta", Δ , in plan view. It is crossed by many distributaries, and resulted from the accumulation of sediment supplied by the river. Most deltas are partly subaerial and partly below water.
Deltaic	Pertaining to or characterized by a delta, e.g., deltaic sedimentation or deltaic coast.
Dendrogram	A tree-like diagram depicting the mutual relationships of a group of items sharing a common set of variables, the variables representing either samples on which multiple measurements have been made or measured attributes for a group of samples.
Dendrograph	A tree-like two-dimensional correlation diagram depicting the mutual relationships between and within groups of items sharing a common set of variables.
Density	The mass or weight of a substance per unit volume (in ppg, lb/ft^3 , or kg/m^3). Also see Specific gravity, and API gravity.

Density log	Measurement of formation porosity. Involves bombarding the formation with gamma rays, with detectors measuring the number of gamma rays that are reflected from the formation.
Depositional karst	Term used in reference to various small-scale karst features (e.g., small dissolution caves and related speleothems and cave cements, dissolution-etched erosion surfaces) formed as a result of short periods of subareal exposure during deposition.
Desiccation	Loss of interstitial water from sediments as a result of drying.
Design of experiments	Methods of obtaining mathematical description or mathematical model of a process under study as a regression equation based on the limited number of reproducible experimental data. Syn: Experimental design.
Detrital	Term generally restricted to sediments derived from the erosion of preexisting rocks. Syn: Terrigenous, Siliciclastic.
Deviation [stat]	The difference between an observation and a fixed value.
Deviation [drill]	Directional change of wellbore from vertical.
Diagenesis	All chemical, physical, and biologic changes in sediments or rocks that have altered their original textures and mineralogies, operative from the time of their formation and deposition, up through lithification.
Diagenetic facies	An assemblage of rocks with similar diagenetic attributes or which have been affected by similar diagenetic histories.
Differential pressure	The difference between two fluid pressures; e.g., the difference between the pressure in a reservoir and in a wellbore drilled through the reservoir.
Diffusion	(a) The spontaneous movement and scattering of particles of liquids, gases, or solids. (b) The migration of dissolved substances from an area of high concentration to an area of low concentration.
Directional drilling	Intentional deviation of a wellbore from the vertical.
Directional survey	A logging method that records drift angle, or deflection from the vertical, and direction (azimuth) of the drift.
Discriminant analysis	A statistical procedure for classifying subsequent samples into categories previously defined and

	differentiated on the basis of samples from known population.
Dispersion [stat]	The extent, to which observations are dissimilar in value, often measured by standard deviation, range, etc.
Dispersion [petr]	A suspension of extremely fine particles in a liquid (e.g., colloids in a colloidal solution).
Dissolution	Process of dissolving substances. Syn: Leaching.
Dissolution-enlargement/ enhancement	In porosity studies, the process of enlarging or otherwise enhancing the size of preexisting pores by dissolution.
Dissolution- reprecipitation	Common process of carbonate dissolution and void formation at the microscale or macroscale, followed by the precipitation of another mineral phase.
Distally-fining	A sequence of rocks wherein sediment size decreases either away from shore, toward deeper water (marine), or from the point of sediment input (marine or terrestrial).
Distillation	Boiling off various fractions of oil at different temperatures.
Distribution [stat]	(a) The partition of observations into intervals by value. (b) The set of frequencies of observations in a set of intervals (frequency distribution). (c) A generic term for mathematical formulae giving probabilities related to values of random variables. The following statistical distributions are distinguished: binomial, chi-square, exponential, <i>F</i> -distribution, geometric, hypergeometric, lognormal, normal, Poisson, standard normal, <i>t</i> -distribution, etc.
Dolomite	A type of sedimentary rock similar to limestone but containing more than 50% dolomite ($\text{CaMg}(\text{CO}_3)_2$).
Dolomitization	Replacement of preexisting carbonate sediment or rock by dolomite.
Dolostone	Synonym for dolomite rock.
Doubles	Two joints of pipe (casing, tubing) fitted together.
Drawworks	The hoisting equipment of a drilling rig.
Drill bit	The cutting or boring element used for drilling. Syn: Bit.
Drill collar	A heavy, thick-walled tube, usually steel, used between the drill pipe and the bit in the drillstem to provide the pendulum effect to the drillstem and weight to the bit.
Driller's log	Continuous recording of types of cuttings, gas, and oil occurrences while drilling the well.

Drilling mud	Fluid composed of water or oil, clays, chemicals, and weighting materials used to lubricate the bit and to move cuttings out of the hole. Syn: Drilling fluid.
Drilling program	Plan for assembling all the personnel, equipment, and supplies for drilling and completing a well.
Drill pipe	Heavy seamless tubing used to rotate the bit and circulate the drilling mud.
Drill ship	Vessel especially designed for offshore drilling operations.
Drillstem test (DST)	Drillstem test employs equipment, which allows a well to flow for a short period of time, gathering information on reservoir fluids and pressure and the ability of the reservoir to produce fluids.
Drillstring	A long continuous string of tubular goods of tubing, drill collars, bit, and subsurface tool. Syn: Drillstem.
Drive mechanism	The natural force present in a reservoir which causes the fluid to move toward the wellbore; the action of one fluid pushing another. Drive mechanism includes water drive, gas cap expansion, solution gas drive, gravity drainage, and combination drive.
Dry gas	Natural gas consisting principally of methane and devoid of readily condensable constituents such as gasoline. Cf: Wet gas.
Dry hole	A well that fails to produce oil or gas.
Duricrust	General term for a hard crust (carbonate, silica, ferruginous, or aluminous) on the surface of land or as a replacive layer in the upper horizons of soils.
E	
Economic geology	The study and analysis of geologic bodies and materials (systems) that can be utilized profitably by man, including fuels, metals, nonmetallic minerals, and water; the application of geologic knowledge and theory to the search for and the understanding of mineral deposits.
Edgewater	Water around the edge of a reservoir — water presses inward.
Effective permeability	A measure of the ability of the porous medium to transmit a particular fluid at the existing saturation, which is normally less than 100%.
Effective porosity	The percentage of interconnected pores in the rock bulk volume that allow the passage of fluids through the rock. See: Porosity.

Effective pressure	Grain-to-grain stress, which is equal to the total overburden pressure minus the pore (fluid) pressure.
Elasticity	A property a material may have of recovering its original shape and size “immediately” after a deforming force has been removed. Elasticity arises from the forces between atoms or molecules and shows that the forces are repulsive when the atoms are closer than some natural spacing, and attractive when they are farther away.
Electric log	Measures the electric characteristics of a formation; the tool transmits signals to the surface. Downhole tools include either normal or lateral device. In both devices (sondes) a constant electric current is passed between electrodes A and B; the resultant potential difference is measured between electrodes M and N. In the normal device, electrodes A and M are on the sonde, and electrodes B and N are, theoretically, located an infinite distance away. In the lateral device, electrodes A, M, and N are on the sonde, and electrode B is located an infinite distance away.
Electric submersible lift	Downhole electric motor and pump, which are used for high volumes of fluid production.
Elevators	Clamps for lifting rods, tubing, and casing.
Enhanced recovery	Techniques that supplement the natural primary recovery mechanism to increase the flow of the reservoir fluids to the wellbore.
Entropy, information theory	A special index in the theory of information which is employed as a criterion of <i>a priori</i> (before the communications were received) indefiniteness of the system. The entropy of a set of events, $H = - \sum_{i=1}^n p_i \log p_i$ where p_i is a probability of each event. The entropy properties: (1) it becomes zero, if one of the states of the system is fully known and the others are impossible; (2) at a given number of states, it becomes maximum, if all the states are equally probable, but increases with the increasing number of states; (3) it is additive, i.e., it is possible to add up entropy of different systems.
Entropy, thermodynamics or statistical mechanics	A macroscopic, thermodynamic quantity, ultimately reflecting the degree of microscopic randomness or disorder of a system. The entropy in a closed system increases to a maximum at equilibrium as the

	consequence of the trend from a less probable to a more probable state.
Eogenetic	All diagenetic processes operative from the time of sediment formation, including marine and meteoric processes, until the sediments or rocks ultimately are buried and away from the influence of surface and near-surface processes.
Eolian	Referring to processes and products of sediment transport, erosion, or deposition by wind.
Epeiric sea	A shallow sea on a broad continental shelf or an inland sea covering large portions of continent; in the latter case, commonly considered to be tideless. Partial syn: Epicontinental sea.
Epibionts	In reference to encrusting organisms or that population of organisms that has encrusted various substrate.
Epigenesis	Late diagenetic processes that have occurred, and resulting products that have formed, in the deep burial environments. Cf: Eogenetic.
Erosion	The physical and/or chemical processes whereby the earthy and rocky materials of the Earth's crust are loosened, dissolved, or worn away, and simultaneously removed from one place to another by running water (including rainfall), waves and currents, moving ice, or wind.
Error	The difference between an observed, calculated, or measured value of a quantity, and the ideal or true value of that quantity. The following types of errors are distinguished: accidental, constant, instrumental, mean-square, personal, probable, random, residual, sampling, standard, statistical, systematic, and also Type I and Type II errors in a hypothesis-testing procedure.
Ethane	A colorless, odorless, gaseous paraffin hydrocarbon, formula C_2H_6 , which occurs in natural gas.
Eustatic	Rise or fall in sea level due to global changes in the volume of the ocean. Cf: Relative sea level change.
Euxinic	An environment of restricted circulation, with stagnant or anaerobic conditions.
Evaporite	One of the sediments which are deposited from aqueous solution as a result of extensive or total evaporation. Examples include anhydrite, rock salt, and various nitrates and borates.

Expectation [stat]	The average value resulting from an infinite series of repetition of an experiment or observations of a random variable. Symbol: <i>E</i> .
Extraclasts	Particles derived from outside the basin of carbonate deposition. Cf: Intraclasts.
F	
Fabric	The orientation, or lack of orientation, of the elements (particles, crystals, cement) in a sedimentary rock.
Facies	Sum of all lithologic, biologic, and diagenetic attributes in a rock from which the origin and environment of deposition can be inferred. The term can be restricted to lithologic facies (lithofacies), depositional facies, biotic facies (biofacies), or diagenetic facies.
Fan	See: Alluvial fan.
Fault	A break in subsurface strata.
Fault trap	The sealing of a porous and permeable reservoir formation by the abutment of an impermeable bed juxtaposed by fault action.
Fenestrae	General term for penecontemporaneously formed shrinkage pores or gas-bubble pores in rocks, both larger than interparticle pore spaces; includes “bird eyes” and larger pores such as sheetcracks. Also in reference to pore types in carbonate rocks. Adj: Fenestral.
Field	An area consisting of a single reservoir or multiple reservoirs all grouped on or related to, the same individual structural feature and/or stratigraphic condition.
Filter cake	The layer of concentrated solids from the drilling mud or cement slurry that forms on the walls of the borehole opposite the porous and permeable formation. See also: Mud cake.
Filtrate	The liquid portion of drilling mud that is forced into porous and permeable formations next to the borehole.
Flare	Burning off excess natural gas at a well or other production site.
Floating offshore drilling rig	A type of mobile offshore drilling unit that floats and is not secured to the seafloor (except for anchors). Floating units include inland barge rigs, drill ships

	and ship-shaped barges, and semisubmersibles. See also: Mobile offshore drilling rig.
Floatstone	Reef rock composed of matrix-supported organic particles, the particles being of allochthonous (transported) rather than in-place origin.
Flocculation	The coagulation of solids in the drilling mud, produced by special additives or by contaminants.
Flow	Movement of fluids through the reservoir.
Flowchart	Diagrammatic representation of the operations involved in an algorithm or a technological process. Flow lines indicate the sequence of operations or the flow of data/information. Syn: Block diagram.
Flow test	Preliminary test to confirm flow rate through a testing tool prior to going downhole. Syn: Formation testing.
Fluidity	The measure of rate with which a fluid is continuously deformed by a shearing stress; ease of flowing. Cf: Viscosity.
Fluid level	Distance between well head and point to which fluid rises in the well.
Fluid loss	The unwanted migration of the liquid part of the drilling mud or cement slurry into a formation, often minimized or prevented by the blending of additives with the mud or cement.
Fluid loss agent	Materials added to the drilling mud to reduce water loss into the formation.
Fluorescent	Instantaneous re-emission of light of a greater wavelength than the light originally absorbed.
Flushed zone	The area near the wellbore, which has had all the original formation water and/or movable hydrocarbons replaced by the invading mud filtrate. Cf: Uninvaded zone.
Fluvial	Of or pertaining to rivers; growing or living in a stream or river; produced by the action of a stream or river.
Formation [strat]	A bed or deposit composed throughout of substantially the same kind of rock. The fundamental unit in lithostratigraphy. Specific features distinguish one rock formation from another.
Formation [drill]	A general term applied by drillers without stratigraphic connotation to a sedimentary rock that can be described by certain drilling or reservoir characteristics: e.g., hard formation, porous formation, productive formation, etc.

Formation resistivity factor	$F = R_0/R_w$, where R_0 is the electrical resistivity of a formation 100% saturated with formation water and R_w is the formation water resistivity. $F = a \times \phi^{-m}$, where ϕ is the porosity, a is the empirical constant, and m is the cementation factor (varies from 1.3 for unconsolidated sands and oolitic limestones to 2.2 for dense sandstones and dolomites). F embodies the effects of grain size, shape, distribution, sorting, and packing.
Formation resistivity index	$F' = R_t/R_0$, where R_t is the true resistivity of a formation saturated with formation fluids (oil, gas, water) in different proportions and R_0 is the resistivity of a formation 100% saturated with formation water. $F' = a(S_w)^{-n}$, where S_w is the water saturation, a is the empirical constant, and n is the saturation exponent (varies from 1.6 for clayey sands to 2 for clean, non-clayey sands and limestones).
Formation testing	The gathering of pressure data and fluid samples from a formation to determine its production potential before choosing a completion method. Syn: Flow test.
Formation Volume Factor (FVF or B)	The volume of oil (and the solution gas dissolved in it) at reservoir pressure, p , and temperature, T , per unit volume of stock-tank oil (at surface, $T = 60^\circ\text{F}$ and $p = 1 \text{ atm}$).
Fossil	Any remains, trace, or imprints of a plant or animal that has been preserved, by natural processes, in the Earth's crust since some past geologic time; any evidence of past life.
Fraction	Percentage or fraction of a separate component of the crude oil having a certain boiling point range.
Fracture acidizing	Acid solution is injected into the formation at a high enough pressure to fracture the formation. The acid etches the new fracture.
Fracturing	Artificial opening up (fracturing) of a formation, by pumping fluids under high pressure, to increase permeability and flow of oil to the well. See also: Hydraulic fracturing, Fracture acidizing.
Framebuilder	Organisms capable of creating massive, generally wave-resistant buildups.
Framestone	Reef rock that has formed as a result of the accumulation of large, in-place fossils that formed the actual framework of the deposits.

Frasch process	Process to remove sulfur from a sulfur-bearing crude oil, by using cupric acid developed by Herman Frasch.
Free gas	Gas present in a vapor state.
Frequency distribution	A systematic arrangement of statistical data (such as graphic or tabular display of the number of observations of a variable) that exhibits the division of the values of the variable into mutually exclusive (but closely related), usually ranked, and exhaustive discrete categories or classes. It indicates the frequencies or relative frequencies that correspond to each of the categories or classes.
Funnel viscosity	Viscosity as measured by the Marsh funnel, based on the number of seconds it takes for 1,000 cm ³ of drilling fluid to flow through the funnel.
Fuzzy set theory	A form of informal set theory in which belonging is replaced by an index of membership between 0 and 1.
G	
Gamma-ray log	Measurement of the natural formation radioactivity to determine lithology.
Gas cap	Free natural gas above the crude oil sometimes present in the reservoir.
Gas cap expansion	Expansion of the gas cap upon reduction of reservoir pressure; it forces reservoir fluids toward the wellbore.
Gas drive	The use of the energy that arises from the expansion of compressed gas in a reservoir to move crude oil to a wellbore.
Gas drilling	Use of compressed natural gas instead of liquid as the circulation medium in rotary drilling. See also: Air drilling.
Gas lift	Injection of gas into the well to lift fluids out of the wellbore.
Gas-oil ratio (GOR)	A measure of the volume of gas produced with oil, expressed in ft ³ /barrel or m ³ /ton.
Gel strength	A measure of the ability of colloidal dispersion to develop and retain a gel form, based on its resistance to shear.
Geochemistry	(a) The study of the distribution and amounts of the chemical elements in minerals, ores, rocks, soils, water, and the atmosphere. (b) The study of the circulation of the elements in nature, on the basis of the properties of their atoms and ions. (c) The study

	of the distribution and abundance of isotopes, including problems of nuclear frequency and stability in the universe.
Geologic system	“A well-organized natural assembly of interconnected and interacting elements of lithosphere having common development history and comprising a single natural unit with properties that are not inherent in its individual elements.” (Buryakovsky, 1992, pp. 273–295).
Geomathematics	Mathematics as applied to geology; “the closely interrelated system involving mathematical and applied statistics, experimental design, and associated computer techniques as applied to geological sciences” (Osborne, 1969, in: Vistelius, 1980). See also: <i>Mathematical geology</i> .
Geophone	Microphone placed near the Earth’s surface to detect seismic waves.
Gilsonite	A black, shiny asphaltite with conchoidal fracture and black streak, which is soluble in turpentine. Syn: Uintahite.
Grainstone	Grain-supported carbonate rock textural type, generally mud-free. Syn: Sparite.
Gravity drainage	Gravity force results in movement of oil downward as the gas migrates upward. This force is strong in steeply dipping reservoirs.
Gum	Naturally occurring or synthetic hydrophylic colloids used to control various properties of drilling fluids.
Gypsum	A naturally occurring crystalline form of calcium sulfate ($\text{CaSO}_4 \cdot 2\text{H}_2\text{O}$).
H	
Hardground	General term for a surficial or near-surficial layer of sediment that is cemented syndepositionally, close to or at the sediment–water interface.
Hard water	Water containing more than 60 mg/l (60 ppm) of hardness-forming constituents (calcium and magnesium) expressed as CaCO_3 equivalent. Cf: Alkaline (soft) water.
Heater-treater	A vessel that heats an emulsion and removes water and gas from the oil to raise it to a quality acceptable for a pipeline or other means of transport. Syn: Oil treater.
Hemipelagic	Deep-sea sediments composed of the remains of pelagic organisms and small amount of terrigenous material.

Histogram	A graphical representation of class frequencies (or relative frequencies) as rectangles against class interval, the value of frequency being proportional to the area of the corresponding rectangle.
Hydraulic fracturing	Fracturing the formation by pumping in a specifically blended liquid under pressure high enough to cause the formation to crack open.
Hydraulic lift	Use of hydraulic pressure to activate the downhole pump.
Hydrocarbon	Any organic compound, gaseous, liquid, or solid, consisting solely of carbon and hydrogen. They are divided into four specific groups: paraffin, cycloparaffin or naphthene, olefin, and aromatic. Crude oil is essentially a complex mixture of hydrocarbons.
Hydrocracking	Method of cracking or breaking up of long-chain hydrocarbons.
Hydrogen sulfide	A toxic, corrosive gas, H_2S , with a characteristic odor of rotten eggs. It is emitted in natural decomposition of organic matter and is present in many crude oils and natural gases.
Hydrophilic	Having strong affinity for water; said of colloids that swell in water and are not easily coagulated.
Hydrophobic	Lacking strong affinity for water; said of colloids whose particles are not highly hydrated and coagulate easily.
Hydrophone	Waterproof microphone used to detect seismic echoes at sea.
Hydrostatic head	Pressure (p) exerted at the bottom of a column of liquid, $p = \gamma D$, where γ = specific weight of liquid (e.g., in lb/ft^3 or kg/m^3), and D = depth (e.g., in ft or m). Syn: Pressure head; Hydrostatic pressure.
Hydrothermal	Alteration of rocks or minerals by the action of heated waters.
Hypersaline	Seawater salinity elevated beyond values of normal salinity (e.g., greater than 34–38‰); also used in reference to environments of extensively high salinity.
Hypothesis testing	The theory and methods used in statistics to test one hypothesis (null hypothesis, H_0) about the probability distributions of a sample population against another (alternative or research hypothesis, H_a).

I

Igneous rock	A rock mass formed by the solidification of material poured (when molten) into the Earth's crust or onto its surface.
--------------	---

Illite	Very common and widely occurring group of clay minerals; crystals form tiny flakes; formed by the weathering decomposition or hydrothermal alteration of muscovite or feldspar. Syn: Hydrous mica, Hydromica.
Induction log	Measurement of the formation resistivity response to the induced current.
Inflow performance relationship (IPR)	Plot of the flowing bottom-hole pressure versus the flow rate, greatly influenced by the reservoir drive mechanism.
Injection	Placing fluids into the reservoir under pressure. See: Carbon dioxide injection, Caustic injection.
In-situ combustion	Enhanced recovery technique by starting a fire at the injector to generate heat and gas to drive oil toward the producing wells.
Interfacial tension	The surface tension occurring at the interface between two liquids that do not mix, such as oil and water.
Internal sediment	Fine-grained sediment, including insoluble residue that has collected in pores in sediments or rocks; such sediment is generated syn-depositionally as a result of organic boring and micritization, or partial dissolution of soluble rocks.
Internal yield	Minimum internal pressure to burst casing (pipe).
Interstitial	Interparticle (either pore space, cement, or fluids).
Intrabasinal	Said of sediments or rocks formed within or derived from the basin of deposition. Cf: Terrigenous.
Intracratonic	Geologic features found on cratons, e.g., intracratonic basins, intracratonic seas.
Intrastratal	Formed or occurring within a given layer or layers. Syn: Intra-formational.
Irreducible fluid saturation	Equilibrium saturation of the wetting phase, which cannot be lowered by flowing indefinitely a non-wetting phase through a porous medium, providing evaporation does not take place.
Isopachous	Cement which completely lines the pores in a rock. Syn: Circum-granular.
Isotropic medium	A medium whose physical properties are the same in all directions. Cf: Anisotropic medium.
J	
Jackup drilling rig	A mobile bottom-supported offshore drilling structure with columnar or open-truss legs that support the deck and hull.
Joint	Single section of a pipe.

K

- Kaolinite** A common, white to grayish, or yellowish clay mineral of a kaolin group; occurs as a secondary mineral produced by alteration of aluminosilicates.
- Karst** Topography (surficial and subsurface) formed as a result of the dissolution of soluble rocks, such as limestones, dolomites, and evaporites, and characterized by closed depressions, caves, and underground drainage.
- Karst towers** Residual hills in karsted terranes. Syn: Buried hills.
- Kelly** A hollow 40-ft-long pipe, having four or more sides and threaded connections at each end to permit it to be attached to the swivel and to the drillpipe. It transmits torque from the rotary drilling table to the drillstring.
- Kelly bushing** A special device that, when fitted into the master bushing, transmits torque to the kelly and simultaneously permits vertical movement of the kelly to make hole.
- Kerogen** The solid, insoluble organic matter (fossilized), which can be converted by distillation into petroleum products.
- Kick** An entry of water, gas, oil, or other formation fluid into the wellbore during drilling. If prompt action is not taken to control the kick or kill the well, a blowout may occur.
- Kill a well** To overcome pressure in a well by use of mud or water so that surface connections may be removed.

L

- LACT** Lease Automated Custody Transfer: fully automated tank battery that records and ships oil and gas into gathering pipeline.
- Lacustrine** Pertaining to lakes or deposits of lakes.
- Latent heat of vaporization** BTUs required to vaporize 1 lb of a liquid at its atmospheric boiling point.
- Leaching** Pertaining to dissolution of soluble minerals or rocks. Partial syn: Dissolution.
- Least square method (LSM)** A statistical method for fitting a line, curve, or higher-degree surface to a set of data such that the sum of the squares of the distances of data points to the fitted line, etc. is minimized.

Level of significance	The probability of committing an error while rejecting the null hypothesis when it is really true or a threshold value of probability at or below which the results of statistical investigation (e.g., hypothesis testing) are held to contradict a particular hypothesis. This probability is expressed as decimal or percentage; level of significance supplements the level of confidence to 1 or 100% (often this probability is set at 0.05 or 5%).
Lift mechanisms	Various methods of lifting oil from the wellbore to the surface. It includes: artificial lift, cable lift, electric submersible lift, gas lift, hydraulic lift, rod lift, and surface lift.
Lighter ends	Volatile components (or fractions) of petroleum.
Lignin	The substance that gives tensile strength to plant structures such as tree trunks. It is a polymer of propylbenzene nuclei joint by oxygen and carbon linkages plus $-OH$ and $-OCH_3$ side chains.
Lignite	A brownish-black coal that is intermediate in coalification between peat and sub-bituminous coal. Cf: Brown coal.
Lime mud	A general term for carbonate sediment composed of particles up to 62 microns in size.
Lipids	A broad term that includes all oil- and water-soluble substances such as fats, waxes, fatty acids, steroids, pigments, and terpenoids.
Lithification	Process of converting unconsolidated sediments to rocks by the addition of mineral cement. Syn: Consolidation. Partial syn: Cementation.
Lithoclast	Mechanically or biogenically formed and deposited fragment (larger than 2 mm) of a weakly lithified sediment or rock, formed within the basin of deposition. Cf: Extraclast.
Lithofacies	See: Facies.
Lithographic texture	Compact, dense, homogenous and exceedingly fine-grained rock with conchoidal or subconchoidal fracture. Partial syn: Micrite, Carbonate mudstone.
Lithology	Descriptive, physical characteristics of rocks such as color, structure, mineralogic composition, grain size, etc.
Live oil	Oil that contains gas.
Log	Continuous record of certain data obtained from a logging tool lowered into the wellbore.

Logging	Recording of data (various physical, chemical, and mechanical properties of reservoir) obtained by lowering of various types of measuring tools into a wellbore. Well-logging includes: acoustic (sonic) log, caliper log, conduction log, density log, driller's log, electric log, gamma-ray log, induction log, nuclear log, neutron log, pressure log, production log, resistivity log, spontaneous potential log, temperature log, and some others.
Lost circulation additives	Materials (fiber, flake, or granular) added to the drilling mud in varying amounts to control or prevent lost circulation.
M	
Mathematical expectation	The average value resulting from an infinite series of repetition of an experiment or observations of a random variable. Syn: Expectation. Symbol: <i>E</i> .
Mathematical geology	Mathematics as applied to geology; "the name given to the discipline devoted to the investigation of probability distributions of values of random variables with the object of obtaining information concerning geological processes" (Vistelius, 1980). These investigations are based on the methods of mathematical probability, statistical theory, and special computational mathematics developed in work on the solutions of various particular problems. Syn: Geomathematics.
Mathematical modeling	The representation by mathematical expressions of a physical system to understand its structure (static mathematical models) and/or behavior (dynamic mathematical models).
Matrix	The continuous material (sediment, cement) composing rocks; the continuous material enclosing interstices in rocks.
Matrix acidizing	Enlargement of preexisting pores without fracturing. Acid can also enlarge (etch) the preexisting fractures.
Maturation [petrol]	Term pertaining to the thermocatalytic state of hydrocarbons, i.e., the evolution of hydrocarbons through the increasing pressure and temperature associated with burial, or to the hydrocarbon source material.
Maturation [sed]	Term pertaining to the mineralogic composition of siliciclastic or carbonate rocks as they approach a

	pure quartz or calcite end-member composition, respectively.
Maturity	In reference to maturation above.
Mean square error (MSE)	The expression of the square of the difference between an estimate of a parameter and its true value, taken with respect to the sampling distribution of the estimate.
Meniscus [lith]	The hour-glass shape of interparticle cements precipitated from fluids held by attraction at grain-to-grain contacts; usually indicative of cement precipitation in the vadose environment.
Meniscus [petr]	The curved upper surface of a liquid column, concave when the containing walls are wet by the liquid (negative meniscus) and convex when they are not (positive meniscus).
Mesh	A measure of fineness of a screen or sieve; e.g., a 200-mesh sieve has 200 openings per linear inch through which a particle of 74 μm can pass.
Mesogenetic	Diagenetic changes in rocks occurring in the deep burial environment. Syn: Catagenetic, Epigenetic.
Metamorphic rock	A rock derived from preexisting rocks by mineralogical, chemical, and structural alterations caused by processes within the Earth's crust.
Metastable	Said of minerals that are unstable at certain temperatures and pressures, or in fluids of certain composition. Partial syn: Unstable.
Meteoric	Water derived ultimately from rain; water of recent atmospheric origin.
Methane	A colorless odorless inflammable gas; the simplest paraffin hydrocarbon, formula CH_4 . It is the principal constituent of natural gas and is also found associated with crude oil.
Mica	A silicate mineral characterized by sheet cleavage, i.e., it separates in thin sheets. There are two major types of micas: biotite, a ferromagnesian black mica, and muscovite, a potassic white mica.
Micrite	Particulate, fine-grained matrix of carbonate rocks, by various definitions, the particles being less than 20 μm or 4 μm in size; a carbonate rock textural type composed dominantly of mud. Syn: Carbonate mudstone.
Micritization	Organic or inorganic process of converting preexisting carbonate cements or grains to micrite.
Microbial	Pertaining to the presence, activities, or products of microbes such as algae, bacteria, fungi, and yeasts.

Microcrystalline	See cryptocrystalline; said of a rock with such a texture.
Microfacies	Term for the features, composition, and appearance of rocks, or of specific diagenetic features, as identified in thin-sections.
Microspar	Fabric of carbonate crystals resulting from recrystallization of micrite-size crystals or grains that range in size from 5 to $\approx 30 \mu\text{m}$.
Migration	The movement of liquid and gaseous hydrocarbons from their source or generating beds, through permeable formations into reservoir rocks.
Miscible drive	Fluid displacement in which the displacing fluid and the displaced fluid become miscible in all proportions.
Miscible mixture	Complete mixture of fluids: single phase.
Mobile offshore drilling unit (MODU)	A drilling rig that is used to drill offshore exploration and development wells and that float upon the surface of the water when being moved from one drill site to another. Two basic types of MODUs are used: bottom-supported drilling rig and floating drilling rig.
Mobility	The ability of a fluid to move through a reservoir.
Model	An accurate simulation, by means of description, statistical data, mathematical equation, or analogy, of an item or process that cannot be observed directly or that is difficult to observe directly.
Mole	The fundamental unit of mass of a substance expressed as the number of grams or pounds indicated by its molecular weight.
Molecular weight	The sum of the atomic weights in a molecule. For example, the molecular weight of water (H_2O) is 18 because the atomic weight of hydrogen is 1 and that of oxygen is 16.
Monomineralic	Composed of one mineral species.
Monte Carlo method	A procedure in statistics employed to obtain numerical solution to mathematical or physical problems by means of random sampling.
Montmorillonite	An expanding-lattice clay mineral, white to gray with tints of blue, pink, and green; usually occurs in massive, microcrystalline aggregates of very fine, scale-like crystals. It is characterized by a three-layer crystal lattice (one sheet of aluminum and hydroxyl between two sheets of silicon and oxygen); subject to swelling on wetting (and shrinking on drying) due to introduction of considerable interlayer water. Syn: Smectite.

Mound	Organic or inorganic sediment buildup with low depositional relief; or organic buildup composed of non-framework building (but commonly gregarious), in-place organisms or allochthonous organisms.
Mud [sed]	Fine-grained particles, by various definitions less than 20 microns or 4 microns in size. Syn: Particulate micrite.
Mud [drill]	See: Drilling mud.
Mudbank	Accumulation of mud [sed].
Mud cake	A clay layer formed where the drilling mud lost water by filtration into a porous and permeable formation during rotary drilling and adhered to the walls of the borehole. See also: Filter cake.
Mud logging	A continuous analysis of the drilling mud and cuttings to determine the presence or absence of oil, gas, or water in the formations penetrated by borehole, and to ascertain the depths of any oil- and gas-bearing formations using geochemical analysis, chromatograph interpretation, and sample description.
Mud program	Plan of supplying and using drilling fluids and their additives during the drilling operations.
Mudstone	(a) Argillaceous or clay-bearing sedimentary rock which is non-plastic and has a massive or non-foliated structure. See: Claystone. (b) Carbonate rock textural type composed dominantly of mud (micrite) with less than 10% grains. See: Lime mud.
Multiple completion	Several producing zones completed for production through one well.

N

Nannofossil	General term for small fossils, the resolution of which is near the limits of the light microscope.
Naphtha	Petroleum distillate used as a cleaning fluid, for example.
Naphthene	See: Cycloparaffin.
Natural gas	A naturally occurring mixture of hydrocarbon and non-hydrocarbon gases found in porous media at depth. It is often associated with crude oil. Composed mainly (≈ 70 to 90%) of methane gas.
Neomorphism	General petrologic term that encompasses both recrystallization (increase in crystal size in case where

- mineralogy is constant) and inversion (crystal fabric changes attending mineralogic conversions).
- Neutron log Measurement of porosity; also valuable information concerning rock composition and fluid content. The logging tool bombards the formation with neutrons.
- Newtonian fluid A fluid in which the viscosity remains constant for all rates of shear if constant conditions of temperature and pressure are maintained. Most drilling fluids behave as non-Newtonian fluids. Syn: Newtonian flow.
- Nuclear log Measurement of porosity, type of fluids and/or gas, lithology, etc., by recording the nuclear properties of the formation.
- O
- Occlusion In reference to porosity reduction as a typical consequences of cementation or compaction.
- Offlap Progressive offshore migration of the updip terminations of sedimentary beds within a conformable sequence of rocks. Cf: Onlap.
- Oil See: Petroleum.
- Oil and gas separator An item of production equipment used to separate liquid components of the well stream from gaseous elements. Separation is accomplished principally by gravity, the heavier liquids falling to the bottom and the gas rising to the top.
- Oil-base mud A drilling or workover fluid in which oil is the continuous phase and which contains about 2–5% of water.
- Oilfield The surface area overlaying an oil reservoir(s). The term usually includes not only the surface area, but also the reservoir, the wells, and the production equipment.
- Oil sample Small volume of oil drawn from a tank for testing; includes bottom sample, composite sample, running sample, spot sample, water, and sediment sample.
- Oil sand Any porous stratum bearing oil.
- Oil treater Equipment used to separate natural gas, BS&W, and water from the oil by the use of heat. Syn: Heater-treater.
- Olefins Group of unsaturated hydrocarbons (one double bond), such as ethylene ($C_{2n}H_{4n}$).

Oncolite	An accretionary carbonate particle composed of a particulate nucleus surrounded by a cortex of algae and entrapped sediment and/or precipitated cement.
Onlap	Progressive onshore migration of the updip terminations of sedimentary beds within a conformable sequence of rocks. Cf: Offlap.
Ooid	An accretionary, sand-size carbonate particle composed of a particulate nucleus surrounded by a laminated cortex of microcrystalline calcium carbonate; oolite is the term commonly used for rocks composed of ooids. Partial syn: Oolite, Oolith.
Ooze	Soft, soupy mud generally composed of at least 30% skeletal remains of pelagic organisms (calcareous or siliceous), the remainder being clay minerals.
Overbalance	The extent to which the hydrostatic pressure of the mud column exceeds formation pressure.
Overburden	Section of rocks overlying a given stratum or strata.
Overburden pressure	Total pressure, p_t , exerted on a reservoir by the weight of the overlying rocks and fluids. It is balanced by the pore pressure, p_p , plus the grain-to-grain stress, p_g (or effective pressure, p_e), $p_t = p_p + p_e$.
Overpressuring/ overpressured reservoirs	Porous rocks characterized by greater than normal hydrostatic pressure resulting, for example, from undercompaction due to rapid sedimentation.
Oxidation	Process in which a given substance loses electrons or a share of its electrons.
P	
Packer	Mechanical device set in the casing (attached to the tubing) to prevent communication between the tubing and annulus.
Packing	Three-dimensional arrangement of particles in a rock.
Packstone	Muddy, but grain-supported carbonate rock textural type.
Paleoenvironment	Ancient depositional (or diagenetic) environment.
Paleogeomorphic	Term used in reference generally to a buried landscape; in reference to hydrocarbon reservoir traps in or along certain buried landscape features.
Paleokarst	Buried or relict karst.
Paleosol	Fossilized soil.
Paraffin	Denotes a solid, waxy material.
Paraffins	Group of saturated aliphatic hydrocarbons with general formula C_nH_{2n+2} .

Pay zone	The zone of production where commercially recoverable oil and/or gas are present, i.e., productive or producing formation. Syn: Pay sand.
Pelagic	Pertaining to open ocean water as an environment; deep-sea sediments without terrigenous material (either inorganic red clays or organic oozes).
Pellet	A particle composed of fecal material. Partial syn: Pelletoid, Peloid.
Peloid	A cryptocrystalline carbonate particle of unrecognizable origin, most likely a completely micritized grain, less likely a fecal pellet. Partial syn: Pellet.
Penecontemporaneous	Contemporaneous with deposition. Syn: Syndepositional.
Perforating	Making holes in the casing (or liner), cement and formation so that formation fluids can enter the wellbore. There are three basic types of perforation: mechanical, gun, and jet.
Periplatform	Said of sediments or environments in deeper water immediately seaward of carbonate platforms, atolls, or banks.
Peritidal	Inclusive term for supratidal and intertidal environments, or in some definitions, supratidal, intertidal, and upper subtidal environments.
Permeability	The ability of a porous medium to transmit fluids. Permeability is equal to one Darcy if 1 cm ³ of fluid flows through 1 cm ² of cross-section of rock per second under a pressure gradient of 1 atm/cm, the fluid viscosity being 1 cP. See also: Absolute permeability, Effective permeability, and Relative permeability.
Petroleum	A naturally occurring complex of liquid hydrocarbons that may contain varying amounts of impurities (sulfur, nitrogen), which after distillation yields a range of combustible fuels, petrochemicals, and lubricants. Syn: Crude oil.
Petrophysics	The physical properties of reservoir rocks and the methods of their study.
pH	The negative logarithm of the hydrogen ion concentration in a solution, $\text{pH} = -\log_{10}1/[\text{H}^+]$. The pH is measured on a scale of 0 to 14; a neutral medium (such as pure water) has pH of 7; $\text{pH} > 7$ indicate relative alkalinity; $\text{pH} < 7$ indicates relative acidity. Most pH values in natural systems lie in the range of 4–9.

Phreatic	Zone below the water table in an unconfined groundwater lens, or in an aquifer, where all the pores are filled with water.
Pinch-out trap	A petroleum trap formed by the thinning out of a porous and permeable rock (e.g., sandstone) between two layers of impermeable rock (e.g., shale). Syn: Wedge-out trap.
Pinnacle reef	An isolated, long (thick), spire or column-shaped reef.
Pisolite	An accretionary carbonate particle, usually larger than sand-size, composed of a particulate nucleus surrounded by a cortex, generally laminated, of precipitated calcium carbonate; term commonly used for rocks containing pisoids or pisoliths. Syn: Pisolith, Pisoid.
Planktonic	In reference to pelagic organisms that float.
Plastic fluid	A complex, non-Newtonian fluid in which the shear force is not proportional to the shear rate. Most drilling muds are plastic fluids. Syn: Plastic flow.
Plasticity	The ability of a substance to be deformed without rupturing.
Platform [drill]	Working surface or deck of a drilling rig, e.g., an immobile offshore structure from which development wells are drilled and produced.
Platform [sed]	A linear region of variable width of shallow-water calcium carbonate deposition.
Play	The extent of a petroleum-bearing formation, e.g., a productive structure.
Playa	A desiccated, vegetation-free, flat-floored area commonly found in deserts, which represents a former shallow desert-lake basin. Syn: Playa lake.
Plug and abandon (P&A)	To place cement plugs into a borehole and abandon it.
Point counter analysis	A statistical method involving the estimation of the frequency of occurrence of an object in a sample (thin-section), determined by counting the number of times that object occurs at specified intervals throughout the sample. The analysis is commonly made with an automatic point counter attached to an optical microscope.
Polycyclic	Pertaining to more than one cycle of formation.
Polygenetic	Pertaining to an origin involving more than one process of formation, or superimposed processes of formation.
Polymer	Compound having many repeated linked units. In oilfield operations, various types of polymers are used

	to thicken drilling mud, fracturing fluids, acid, water, and other liquids.
Polymineralic	Composed of more than one mineral.
Polymorph	A mineral species with more than one crystal form, e.g., CaCO ₃ , calcite (hexagonal) and aragonite (orthorhombic).
Population [stat]	Any theoretical group of items or samples all of which are capable of being measured statistically in one or more respects; all possible values of a variable, either finite or infinite, or continuous or discrete.
Pore	A hole, opening, or passageway in a rock. Syn: Interstice.
Porosity	Absolute or total porosity is the total of all void spaces present within a rock, but not all these spaces will be interconnected and thus able to contain and transmit fluids. The effective porosity is thus defined as the proportion of the rock, which consists of interconnected pores. Porosity is expressed as a percentage of the bulk volume of the rock.
Porosity terms	(a) Fabric-selective porosity: pores that occur in regard to specific elements in the rock. Cf: Non-fabric-selective. (b) Framework porosity: porosity in the matrix of rocks, exclusive of fractures. Syn: Matrix porosity. (c) Porosity-specific: porosity occurrence within a given rock type or paleodepositional facies. (d) Pore system: the total petrophysical attributes of a porous unit. (e) Primary porosity: porosity inherited from the depositional environment. Cf: Secondary porosity. (f) Secondary porosity: developed after deposition as a result of dissolution, for example. Cf: Primary porosity.
Postdepositional	Physical or chemical changes in sediments or rocks after final deposition and burial.
Pour point	The temperature at which a liquid hydrocarbon ceases to flow, or at which it congeals.
Precision	(a) The degree of agreement or uniformity of repeated measurements of a quantity. Precision relates to the quality of the operation by which a result is obtained, as distinguished from accuracy. (b) The deviation of a set of estimates or observations from their mean.
Pressure gradient	The difference in pressure at two given points, divided by the distance between these two points.

Pressure head	The height (h) of a column of liquid supported by pressure at a point in a liquid: $h = p/\gamma$, where h is the head of liquid (e.g., in ft), p is the pressure (e.g., in lb/ft ²), and γ is the specific weight of liquid (e.g., in lb/ft ³). Syn: Hydrostatic head.
Pressure log	Measurement of the formation pressure at various depths.
Pressure solution	Process in which carbonate dissolution occurs at burial as a result of increased pressure due to overburden stress; usually results in the formation of stylolites and interpenetrative grain contacts. Syn: Pressure dissolution.
Primary cementing	The cementing operation that takes place immediately after the casing has been run into the hole.
Primary recovery	The production obtained using the initial reservoir energy.
Probability [stat]	A statistical measure of the likelihood of occurrence of an event.
Production log	Measurement of production status of a completed well. Yields information on the nature and movement of fluids within the well.
Production test	A test of the well's producing potential usually done during the initial completion phase.
Productivity index	It is equal to $PI = q/(p_r - p_{wf})$, where q is the flow rate (e.g., bbl/d); p_r is the average reservoir pressure (e.g., psia); and p_{wf} is the flowing bottom-hole pressure at the wellbore (psia).
Progradation	The seaward accretion and migration of sedimentary bodies and corresponding depositional environments. Cf: Regression [sed].
Protodolomite	Term used in reference to dolomite that is poorly ordered and compositionally impure (i.e., calcic).
Provenance	The source or place of origin of detrital sediments.
Pseudospar	Fabric of carbonate crystals, resulting from recrystallization of micrite-size crystals or grains, that are larger than 30 μm in size.
Pumping	Lifting fluids from the production well to the surface by an artificial lift method.
Pumping off	Pumping the reservoir fluids out of the well faster than they can enter the wellbore.
PVT analysis	An examination of reservoir fluid in a laboratory under various pressures, volumes, and temperatures to determine the characteristics and behavior of the fluid.

Q

- Quantile [stat] The argument of the cumulative distribution function corresponding to a specified probability; (of a sample) the value below which occur a specified proportion of the observations in the ordered set of observations.
- Quartile [stat] The argument of the cumulative distribution function corresponding to a probability of either $\frac{1}{4}$ (first or lower quartile), $\frac{1}{2}$ (second or middle quartile or median) or $\frac{3}{4}$ (third or upper quartile). In a sample, the value below which a quarter, one-half or three-quarters of the observations occurs in the ordered set of observations.

R

- Radial flow Two-dimensional flow from all points around a 360° circle within a formation to a centered well.
- Radioactivity logging The recording of the natural or induced radioactive characteristics of subsurface formations. A radioactivity log normally consists of two recorded curves: a gamma-ray curve and a neutron curve.
- Ramp A carbonate depositional surface that dips very gently ($<1^\circ$) in a seaward direction, passing imperceptibly from shallow to deep water.
- Rate of Penetration (ROP) Speed with which the drilling bit cuts through the formation.
- Rate of shear Rate (in rpm) at which an action resulting from applied forces causes or tends to cause two adjacent parts of a body to slide relative to each other in a direction parallel to their plane of contact.
- Recovery The petroleum produced from the reservoir in % (or fraction) of the total oil in-place reserves; it is subdivided into primary, secondary, and tertiary recovery.
- Recrystallization Term that refers to an increase in the size of existing crystals without a change in mineralogy.
- Redox potential (Eh) A scale of values, measured as electric potential in volts, indicating the ability of a substance or solution to cause reduction or oxidation reactions under non-standard conditions. The higher the value of Eh, the more oxidizing the conditions.
- Reduced pressure The absolute pressure at which the gas exists divided by the absolute critical pressure: $p_r = p/p_{cr}$.

Reduced temperature	The absolute temperature divided by the absolute critical temperature: $T_r = T/T_{cr}$.
Reduction	Process in which a given substance gains electrons.
Reef	An organic buildup made of the remains of sedentary calcareous organisms, especially corals.
Regression [sed]	Retreat of the sea from land areas; also, any change that converts offshore, deep-water condition to the near-shore, shallow-water conditions. The landward migration of sedimentary bodies and corresponding depositional environments. Cf: Transgression.
Regression [stat]	A model of the relationship between the expected value of a random variable and the values of one or more possibly related variables.
Relative frequency	In a particular class interval, a fraction (as decimal or percentage) of the total number of occurrences or events in the sample.
Relative permeability	Ratio of the effective permeability at a given saturation of that fluid to the absolute (single-phase fluid) permeability at 100% saturation.
Repeatability	A precision with which a measured value can be repeated in an experiment.
Replacement	When one mineral replaces the another mineral, e.g., dolomitization, silicification.
Representative sample	A sample that, well enough, represents the proportions of the whole population.
Resedimentation	Refers to sediments, originally formed and deposited in one environment and subsequently transported to a completely different environment.
Reservoir	A subsurface accumulation of crude oil or natural gas under adequate trap conditions.
Reservoir pressure	The average pressure within the reservoir at any given time.
Reservoir rock	A porous and permeable rock holding an accumulation of crude oil and/or natural gas. Sandstones and carbonates (limestones and dolomites) are the usually encountered reservoir rocks.
Resin	(a) Any of various hard, brittle, transparent or translucent substances formed esp. in plant secretion and obtained as exudates of recent or fossil origin by the condensation of fluids or the loss of volatile oil. Resins are yellowish to brown in color, with a characteristic luster; they are fusible and flammable, are soluble in ether and other organic solvents but not in water.

- (b) Semisolid or solid complex, amorphous mixture of organic compounds having no definite melting point or tendency to crystallize.
- Resistivity log Defines the reservoir contents. Electric current flows in the formation between two electrodes on a logging tool and measures resistivity between those two points.
- Reynolds number The dimensionless number defined as $R_e = \rho v d / \eta$ where ρ is the density of a fluid with viscosity η traveling at velocity v in a pipe of diameter d . Above $R_e = 2,000$, flow is turbulent. Below, it is laminar.
- Rheology The study of fluid flow, esp. of fluid elasticity, viscosity, and plasticity, which is of special importance to mud engineers and reservoir engineers.
- Rhizoconcretion, rhizolith An accumulation of calcium carbonate around plant roots.
- Rhodolite An accretionary carbonate particle, larger than sand-size, with or without a nucleus surrounded by a laminated to massive cortex constructed by red (rhodophyte) algae. Syn: Rhodolith, Rhodoid.
- Rimmed shelf/platform A shallow water platform of deposition, the seaward edge of which is defined by a submarine topographic high constructed by carbonate sands or reef buildups.
- Rod Sucker rod is attached to the downhole pump, usually having a length of 16–1/2 ft.
- Rod lift Use of solid metal rods to activate the downhole pump.
- Root mean square (RMS) Square root of sum of squares of individual observations divided by total number of observations.
- Rotary drilling A drilling method that imparts a turning or rotary motion to the drill string to drill the hole.
- Rotary table The principal component of rotary machine used to turn the drill string and support the drilling assembly.
- Rudstone Reef rock composed of grain-supported texture of allochthonous (transported) rather than in-place organic particles.
- Running sample Oil sample taken by lowering an unstoppered beaker from the top outlet level to the bottom outlet and returning it at a uniform rate of speed so that it is about three quarters full when returned.

S

- Salt dome A dome that is caused by an intrusion or piercing of rock salt into overlying deposits, which are usually

	arched so that they dip in all directions away from the center of the dome.
Sample [geol]	A representative unit of a rock, cuttings, fluid, ore, fossil population, or other entity for analysis or display.
Sample [stat]	A set of items selected from the population; if properly selected may be used to estimate parameters of population.
Sampling [stat]	The process of selecting items from the population.
Sapropel	Material composed of plant remains, most commonly algae, that is or has macerated and putrefied in an anaerobic environment: source material for petroleum and natural gas.
Saturation	Percentage of a particular fluid in a porous medium, expressed as the percent of the pore volume.
Scale inhibitor	Chemicals introduced into the producing well to prevent the buildup of scale, paraffin, etc. These can block off the flow of fluids and gas into the wellbore.
Schizohaline	Said of a water body or environment of fluctuating salinity.
Screen liner	Perforated pipe or wire mesh screen placed at the bottom of the well to prevent larger formation particles from entering the wellbore.
Seal	An impermeable bed that acts as a barrier to the vertical or lateral migration of hydrocarbons.
Sea-marginal	Environments close to the sea, such as lagoons, tidal flats, beaches, or deposits in these environments. Syn: Marine-transitional.
Secondary cementing	Any cementing operation after the primary cementing operation including a plug-back job.
Secondary recovery	The production obtained by introducing a second source of energy, i.e., waterflooding.
Sediment [geol]	Solid fragmental material, or a mass of such material, either inorganic or organic, that originates from weathering of rocks and is suspended in, transported by, and deposited by air, water, or ice. Sediment can also form as a result of coagulation of clays, chemical precipitation from solution, or secretion by organisms. It forms in layers on the Earth's surface at ordinary temperatures in a loose, unconsolidated form; e.g., sand, gravel, silt, mud, loess, alluvium.
Sediment [prod]	Particulate material (clay, silt, etc.) that is carried along with the produced fluids and settles to the bottom of the tank.

Sedimentary rock	A layered rock originated from the compaction and/or consolidation of sediments, including a clastic rock such as sandstone or siltstone, a chemical rock such as rock salt or gypsum.
Semisubmersible drilling rig	Marine drilling rig that can either be anchored to the bottom of sea or maintained at a given position.
Sensitivity analysis	Statistical analysis of sensitivity (variability) of different parameters of a process or system as the response to some action or influence on the process or system.
Separator	Equipment for separating the crude oil from the natural gas and water. The primary function of the separator is to produce gas-free liquid and liquid-free gas.
Sequence	A succession of geologic events, processes, or rocks, arranged in chronological order.
Set theory	The branch of mathematics, which is concerned with the study of sets, i.e., any collection of items (elements) defined by specifying the elements. See also Fuzzy set theory.
Shale-out trap	A petroleum trap formed by the lateral variation or facies change of a porous sandstone in which the clay constituents increase and the hard mineral grains are reduced until porosity and permeability disappear and the bed grades to claystone or shale. Cf: Pinch-out trap.
Shale shaker	Mechanical device (vibrating screen) for separation of drilling cuttings from the drilling fluid as it arrives at the surface.
Shear	Action or stress that results from applied forces and that causes or tends to cause two adjoining portions of a substance or body to slide relative to each other in a direction parallel to their plane of contact.
Shelf	A gently sloping or near-horizontal, shallow, marine platform. A stable cratonic area that was periodically flooded by shallow marine waters and received a thin, well-winnowed cover of sediments.
Shoal	Area of shallow water.
Sidetracking	Drilling a new section of wellbore parallel to a previously drilled hole but blocked with junk.
Sidewall core	Core generally one inch in diameter taken from the side of the wellbore, often by wireline.
Silcrete	A soil-replacive or sand and gravel-replacive deposit composed of silica.

Siliciclastic	In reference to terrigenous detrital sediment composed of silicate mineral grains.
Simulation	The representation of a real system by a device (such as a computer, model, or piece of equipment) that imitates the structure and behavior of the system.
Skewness	A statistical measure of the state of asymmetry shown by a frequency distribution curve that is bunched on one side of the mean and tails out on the other side.
Smectite	A highly swelling family of clay minerals that includes montmorillonite and bentonite.
Solution gas	Gas dissolved so thoroughly in the crude oil that the solution behaves as one phase. Gas bubbles dissolved in the oil push the latter toward the wellbore.
Sonic log	A type of acoustic log that records the travel time of sounds through objects, cement, or formation rocks.
Sorting	A measure of the spread or range of particle size distribution about the mean in a sediment population.
Source rock [petrol]	Sedimentary rock deposited together with the organic material, which under pressure, heat, and time was transformed to liquid or gaseous hydrocarbons. Source rock is usually shale and limestone.
Source rock [sed]	The rock from which fragments and other detached pieces have been derived to form later a sedimentary rock. Syn: Parent rock, Mother rock.
Sour gas (or crude oil)	An acid gas (or crude oil) containing a significant amount of hydrogen sulfide (H ₂ S) and carbon dioxide (CO ₂). Cf: Sweet gas (or crude oil).
Sour gas (or oil)	Gas or oil which contains hydrogen sulfide.
Spar	Term for coarse crystalline calcite; commonly used in reference to precipitated cement and may be used for coarse crystalline, recrystallized micrite. Syn: Sparry.
Sparite	Grain-supported, mud-free carbonate rock textural type. Syn: Grainstone.
Specific heat	Quantity of heat required to raise the temperature of a unit weight of material by one degree.
Specific surface	Surface of pores and pore channels per unit of pore volume (commonly), per unit of bulk volume, or per unit of grain volume.
Spontaneous potential (SP)	Measurement of the difference in potential between the formation and the Earth's surface — identification of rock types.
Spot sample	Oil sample obtained from a particular level of the tank.

Squeeze cementing	Placing cement by squeezing it under pressure.
Standard deviation	A statistical measure of dispersion equal to the square root of the ratio of the sum of the squared deviations from the mean of a set of observations to either the sample size (the population standard deviation) or the sample size minus one (the sample standard deviation); i.e., the square root of the variance. Syn: Root Mean Square (RMS) deviation. Symbol: σ .
Statistics	A branch of mathematics concerned with the collection, classification, tabulation, and study of numerical facts or the mathematical study of methods of summarizing or describing data (descriptive statistics) and then drawing inferences from the summary measures (inferential statistics).
Strain	The dimensional change in the shape or volume of a body as a result of an applied stress.
Strand, strandline	The zone of contact between the sea and land commonly represented by beach deposits.
Stratigraphic trap	The sealing of a reservoir bed as the result of lithologic changes rather than through structural trapping conditions. See also: Pinch-out trap, Shale-out trap.
Stress	A measure of the intensity of a force (F) acting upon an area A of a body. $\text{Stress} = F/A$ can be expressed in units of N/m^2 . Stress can be resolved into two components: (1) compressive (tensile) stress acts normal to the surface and changes the volume of the body, and (2) shear stress acts parallel to the surface and changes the shape of the body.
Stromatolite	A laminated organo-sedimentary deposit, either planar or dome-shaped, constructed by the sediment trapping and binding activities, together with some amount of syndepositional lithification, of blue-green algae (cyanobacteria).
Structural trap	The containment of oil or gas within a reservoir bed as the result of bed bend or flexure. Syn: Anticlinal trap.
Stylolite	A pressure-solution feature, generally formed in moderately to deeply buried rocks, characterized by a thin seam or suture of irregular, interlocking, saw-toothed appearance.
Subaerial	Referring to exposure on land, to meteoric fluids.
Subsidence	Local or regional downwarping of a depositional surface due to tectonism or sediment loading. Subsidence of land surface can occur as a result of

	fluid (oil and/or water) withdrawal from the oil/gas-and water-producing formations.
Subunconformity	Position of strata beneath an unconformity.
Sucrosic	General, non-genetic term for coarse crystalline texture, used mostly in reference to dolomites; a porosity term referring to intercrystalline pores within coarse crystalline dolomites.
Sulfuric acid karst	Dissolution, generally of carbonate strata, by sulfuric acid generated from the oxidation of upward migrating, H ₂ S-bearing fluids from depth.
Supraunconformity	Position of strata directly above an unconformity.
Surface lift	Any lifting equipment at the surface such as a pumping unit.
Surface tension	The tendency of liquids to maintain as small a surface as possible. It is caused by the cohesive attraction between the molecules of liquid.
Surfactant	A soluble compound that concentrates on the surface boundary between two substances such as oil and water and reduces the surface tension between them. The use of surfactant permits the thorough surface contact or mixing of substances that ordinarily remain separate. Surfactants are used in the petroleum industry as additives to drilling mud and to water during chemical flooding or well stimulation.
Swabbing	Raising and lowering rubber cups in the tubing to recover liquids.
Sweet gas (or crude oil)	Gas or crude oil devoid of hydrogen sulfide and carbon dioxide.
Syn depositional	Physical, biologic, or diagenetic processes occurring during sediment deposition. Syn: Synsedimentary.
Synergistic effect	The added effect produced by two processes working in combination. It is greater than the sum of the individual parts.
System	Generally, anything formed of parts placed together or adjusted into a regular or connected whole.
Systems analysis	Complete analysis of all phases of behavior of a system, and development of a detailed procedure for all collection, manipulation and evaluation of data associated with the activity of all parts of the system.
Systems approach	A sophisticated philosophy and a scientific method for investigation through mathematical modeling (simulation) of very complicated dynamic systems, which cannot be modeled through material or physical procedures, and which assumes that the given feature is an integrated assembly consisting of

interconnected and interacting elements with new, systems properties.

T

- Tar** A thick black or dark brown viscous liquid obtained by the destructive distillation of coal, wood or peat.
- Telogenesis** Diagenetic alteration in the subaerial meteoric environment of rocks that once were deeply buried.
- Temperature log** Measurement of the formation temperature at various depths. It is also used to determine the height of cement behind the casing and to locate the source of water influx into the wellbore. Syn: Temperature survey.
- Ternary diagram** A triangular diagram that graphically depicts composition of a three-component mixture or ternary system. The perpendicular distances of a point from each of the three sides (in an equilateral triangle) will then represent the relative amount of each of the materials represented by the apexes opposite those sides.
- Terrigenous** Sediments, typically siliciclastic, derived from the erosion on land of preexisting rocks. Syn: Detrital.
- Tertiary recovery** The production obtained by introducing a third source of energy, i.e., enhanced oil recovery, such as thermal, CO₂ flooding, surfactants, polymers, alkaline flooding, in-situ combustion, and DC electrical current.
- Texture** General physical appearance or characteristics of a rock, including parameters such as size, shape, sorting, and packing of constituent particles.
- Theory of information** The mathematical study of information, its storage by codes, and its transmission through channels of limited capacity. A fundamental idea is the entropy of a set of events. See: Entropy, theory of information.
- Thixotropy** The property exhibited by a fluid that is in a liquid state when flowing and in a semisolid, gelled state when at rest. Most drilling fluids must be thixotropic so that cuttings will remain in suspension when the pipe is not in use.
- Tidal flat** Environment and deposits therein, formed in the intertidal zone (including neighboring supratidal and upper subtidal environments and deposits). Syn: Peritidal flat.
- Tight formation** A petroleum- or water-bearing formation of relatively low porosity and permeability. Syn: Hard rock.
- Torque** Turning or twisting force on a drilling string.

Tortuosity	Square of the ratio of the effective length, L_e , to the length parallel to the overall direction of flow of the pore channels, $\tau = (L_e/L)^2$.
Total depth (TD)	The maximum depth reached in a well.
Tract	A region or area of land that may be precisely or indefinitely defined.
Transgression	The spread of the sea over land areas; also, any change that brings offshore, deep-water environments to areas previously occupied by near-shore, shallow-water environments. The term transgressive is used in reference to sediments deposited during a transgression. Cf: Regression. Syn: Sea invasion.
Trap [petrol]	The accumulation of petroleum in a reservoir rock under such conditions that its migration and escape is prevented. Sealing can be effected by the abutment of impermeable formations against the reservoir (e.g., stratigraphic trap, unconformity trap), by lateral variation within the bed to reduce permeability (e.g., pinch-out trap, shale-out trap), by the presence of water preventing downward migration (e.g., structural trap), or by the presence of impermeable fault preventing lateral migration (e.g., fault trap).
Trap [prod]	A device for separating sediment from flowing oil or water. Syn: Sand trap.
Traveling block	Arrangement of pulleys on the drilling rig with an attached hook, which moves up and down on cables running through the crown block.
Trip	Process of pulling drillstring (or tubing) out of the wellbore and then running it back in.
Trip gas	Gas that enters the wellbore when the mud pump is shut down and pipe is being pulled from the wellbore. The gas may enter because of reduction in bottomhole pressure when the mud pump is shut down, because of swabbing, or because of both.
Tubing	Relatively small-diameter pipe that is run into the well to serve as a conduit for the passage of oil and gas to the surface.
Turbidite	A sediment deposited from a turbidity current. It is characterized by graded bedding, moderate sorting, and well-developed primary structures, especially lamination.
Turbodrills	A rotary drilling method in which fluid pumped down the tubing turns the drill bit. The downhole motor consists of multistage vane-type rotor and stator section, bearing section, drive shaft, and bit-rotating sub.

- Turbulent flow** The erratic, nonlinear flow of a fluid caused by high velocity. Cf: Laminar flow.
- U
- Ultraviolet light** Light waves shorter than the visible blue violet waves of the spectrum. Crude oil, colored distillates, residuum, a few drilling fluid additives, and certain minerals and chemicals fluoresce in the presence of ultraviolet light.
- Unconformity** A substantial break or gap in the geologic record where a rock unit is overlain by another that is not next in the stratigraphic succession.
- Unconformity trap** A stratigraphic trap associated with an unconformity.
- Underbalanced** Of or relating to a condition in which pressure in the wellbore is less than the pressure in the formation.
- Uninvaded zone** The area far enough away from the borehole so as not to have been invaded by the filtrate of drilling mud. Cf: Flushed zone.
- Upward-shoaling** A vertical section of deposits that records continually decreasing paleowater depths.
- V
- Vadose** That zone in an unconfined groundwater lens wherein the pores in the sediments are filled mostly with air. Cf: Phreatic.
- Viscosity** Measure of the internal resistance of a fluid to flow. Viscosity is equal to the ratio of shearing stress to the rate of shearing strain. There are two kinds of viscosity: (1) absolute or dynamic viscosity and (2) kinematic viscosity. Cf: Fluidity.
- Vitrinite** A coal maceral group that is the dominant organic constituent of humic coals. Vitrinite forms the familiar brilliant black bands of coal. Vitrinite particles are found in about 80% of the clays and sands.
- Vitrinite reflectance** One of the petrographic components of coals used for the determination of paleotemperatures based on the thermogenic changes in optical properties of the organic matter. The reflectance of vitrinite is determined by microscopic examination of polished sections, measuring and comparing the electric currents generated in a photomultiplier under the influence of light reflected from the polished surface of the rock sample and from the standard with a

Vug	known reflection. The reflectance of vitrinite is determined in immersion oil (R^o) and also in air (R^a). A small cavern in a rock, larger than a pore.
W	
Wackestone	A mud-supported carbonate rock with greater than 10% particles.
Water and sediment sample	Sample of oil taken for obtaining the water and sediment content, usually by centrifuging.
Water-base mud	A drilling mud in which the continuous phase is water.
Water block	A reduction in the permeability of a formation caused by the invasion of water into the pores.
Water cut	Percentage (by volume) of water associated with the produced oil.
Water drive	The reservoir-drive mechanism in which oil is produced by the expansion of the underlying or edge water (as a part of aquifer), which forces the oil into the wellbore.
Waterflooding	A method of improved recovery in which water is injected into the reservoir through the special injection wells to remove additional quantities of oil that have been left behind after primary recovery.
Weathering	The destructive physical and/or chemical processes constituting that part of erosion whereby earthy and rocky material on exposure to atmospheric agents at or near the Earth's surface are changed in character (color, texture, composition, firmness, or form), with little or no transport of the loosened or altered material.
Weight indicator	Device that constantly measures the weight of the drillstring on a drilling rig.
Well completion	The activities and methods of preparing a well for the production of oil and gas or for other purposes, such as injection; the method by which one or more flow paths for hydrocarbons are established between the reservoir and the surface.
Wet gas	A natural gas containing liquid hydrocarbons. Cf: Dry gas.
Wettability	The ability of a liquid to form a coherent film on a solid rock surface, due to the dominance of molecular attraction between the liquid and the solid surface over the cohesive force of the liquid itself.
Wildcat	A well drilled in an area where no oil or gas production exists.

Wireline	A rope made from steel wire.
Wireline formation tester	A formation fluid sampling device, actually run on conductor line rather than wireline, that also logs flow and shut-in pressure in formation near the wellbore.
Workover	Remedial work on a well, i.e., cleaning, repairing, servicing, stimulating, etc., after commencement of production.
Y	
Yield point	The resistance to initial flow, or the stress required to start fluid movement. The values of the yield point and thixotropy are the measurements of the same fluid properties under dynamic and static conditions, respectively. Syn: Yield value.
Z	
Zone of lost circulation	Openings in the formation (fractures, etc.) into which the drilling mud is lost without returning to the surface during the drilling operations.

This page intentionally left blank

REFERENCES AND BIBLIOGRAPHY

- Abasov, M. T., Buryakovsky, L. A. and Dzhafarov, I. S., 1984. Simulation of predicted hydrocarbon resources. *Proc. XXVII International Geological Congress*, Section 20, III, pp. 317–318.
- Abasov, M. T., Dzhafarov, I. S. and Dzhafarova, N. M., 1987. *Foundations of Computerized Geological Interpretation and Analysis*. Elm Press, Baku.
- Afanasyev, V. G., 1973. On the systems approach in social conscience. *Philosophic Issues*, 6: 8–12.
- Afanasyev, V. G., 1980. *Systems Approach and the Society*. Politizdat, Moscow, 368 pp.
- Akramkhodzhayev, A. M., 1973. *Organic Matter as a Major Source of Oil and Gas*. Fan Press, Tashkent, 204 pp.
- Akramkhodzhayev, A. M. and Amir Khanov, Sh. Kh., 1977. On actual amount of sorbed methane and higher hydrocarbons in insoluble organic matter, host rocks and coal. *Uzbek Geologic Magazine*, 4: 3–40.
- Akramkhodzhayev, A. M., Kirshin, A. V. and Kushnir, M. I., 1978. On the oil generating potential of dispersed organic matter and its quantitative estimation. *Uzbek Geologic Magazine*, 4: 89–91.
- Aksenov, A. A., Vorobyev, V. T., Mamadzhanov, Z. A. et al., 1990. Oil and gas forecast for intermountain depressions of the Central Asia and Kazakhstan based on integrated interpretation of geological-geophysical and space information. *Proc. VNIIOENG, Series of Geology, Geophysics and Development of Oil Fields*, Moscow, 59 pp.
- Aleksandrov, B. L., 1987. *Abnormally High Formation Pressures in Petroleum Basins*. Nedra Press, Moscow, 216 pp.
- Allen, P. A. and Allen, J. R., 1990. *Basin Analysis: Principles and Applications*. Blackwell, Oxford, 427 pp. Reprinted, 1993.
- Ammosov, I. I., Gorshkov, V. I., Grechishnikov, N. P. et al., 1987. *Organic Matter Petrology in the Geology of Fossil Fuels*. Nauka Press, Moscow, 333 pp.
- Amott, E., 1959. Observations relating to the wettability of porous rock. *Trans. AIME*, 216: 156–162.
- Andreyev, P. F., Bogomolov, A. I., Dobryanskiy, A. F. et al., 1958. *Oil Transformations in the Nature*. Gostoptekhizdat, Leningrad, 273 pp.
- Anikiev, K. A., 1964. *Abnormally High Reservoir Pressures in Oil and Gas Fields*. Nauka Press, Leningrad, 167 pp.
- Antonellini, M. and Aydin, A., 1994. Effect of faulting on fluids in porous sandstones and petrophysical properties. *Bull. Am. Assoc. Petrol. Geol.*, 78(3): 355–377.
- Aoyagi, K., Kazama, T., Sekiguchi, K. and Chilingarian, G. V., 1985. Experimental compaction of Namtormorillonite clay mixed with crude oil and seawater. *Chem. Geol.*, 49: 385–392.
- Arkhangelskiy, A. D., 1954. Oil generation conditions in the North Caucasus. *Selected Works*, 2. The USSR Academy of Sciences Publishing, pp. 321–436.
- Arnold, V. I., 1983. *Theory of Catastrophes*. Moscow State University Publishing, 80 pp.
- Babalyan, G. A., 1956. *Problems of Oil Recovery Mechanism*. Aznefteizdat, Baku, 254 pp.
- Bagir-zadeh, F. M., Buryakovsky, L. A. and Babayev, F. R., 1974a. *Geochemistry of Oil and Gas in the Absheron-Prebalkhan Anticlinal Trend*. Nedra Press, Moscow, 288 pp.
- Bagir-zadeh, F. M. and Buryakovsky, L. A., 1974b. *Principles of Marine Petroleum Geology*. Elm Press, Baku, 125 pp.
- Bagrintseva, K. I., 1977. *Carbonate Rocks as Oil and Gas Reservoirs*. Nauka Press, Moscow, 247 pp.
- Baird, R. A., 1986. Maturation and source rock evaluation of Kimmeridgian clay, Norwegian North Sea. *Bull. Am. Assoc. Petrol. Geol.*, 70(1): 1–11.

- Baker, J., and Patrice, 1992. Postdepositional history of the Permian sequence in the Denison Trough, Eastern Australia. *Bull. Am. Assoc. Petrol. Geol.*, 76(8): 1224–1249.
- Baker, R. A., Gehman, H. M., James, W. R. and White, D. A., 1986. Geologic field number and size assessment of oil and gas plays. *Oil and Gas Assessment, Methods and Applications. AAPG Studies Geol.*, 21: 133–142.
- Bakirov, A. A., 1976. Geologic principles in zonation of oil and gas-bearing territories. *Principles of Geologic Zonation*. Nedra Press, Moscow, pp. 16–52.
- Bakirov, A. A., Bakirov, E. A. and Mstislavskaya, L. P., 1984. Systems analysis in forecasting oil and gas occurrences in the subsurface. *Systems Approach to Forecasting, Exploration and Appraisal of Oil and Gas Accumulations. Proc. MINKhGP*, 175: 4–21.
- Bakirov, A. A., Bordovskaya, M. V., Yermolkin, V. I. et al., 1991. *Oil and Gas Geology and Geochemistry (Textbook for Higher Education)*. Nedra Press, Moscow. 288 pp.
- Barker, C. and Takach, N. E., 1992. Prediction of natural gas composition in ultra-deep sandstone reservoirs. *Bull. Am. Assoc. Petrol. Geol.*, 76(12): 1859–1873.
- Bars, E. A., 1984. Natural water-head systems. *Reference Book of Oil and Gas Geology*. Nedra Press, Moscow, pp. 310–312.
- Beletskaya, S. N., 1990. *Primary Migration of Oil*. Nedra Press, Moscow, 288 pp.
- Belousov, V. V., 1939. *Greater Caucasus*. Proc. TsNIGRI, 108 pp.
- Belousov, V. V., 1975. *Principles of Geotectonics*. Nedra Press, Moscow, 334 pp.
- Bertalanffy, L. von, 1969. General theory of systems. Review of problems and results. *Systems Studies. 1969 Yearbook*, Nauka Press, Moscow, pp. 30–54.
- Binder, R. C., 1962. *Fluid Mechanics*, 4th ed. Prentice-Hall, Englewood Cliffs, NJ, 453 pp.
- Blauberg, I. V., Sadovskiy, V. N. and Yudin, E. G., 1969. Systems studies and general theory of systems. *Systems Studies. 1969 Yearbook*, Nauka Press, Moscow, pp. 7–29.
- Blauberg, I. V. and Yudin, E. G., 1973. *Establishing and Substance of the Systems Approach*. Nauka Press, Moscow.
- Bogdanov, A. A., 1925, 1927, 1929. *Universal Organizational Science (Tectology), Parts I, II, III*. Moscow, Leningrad.
- Bolshakov, Yu. Ya., 1986. Oil accumulation formation conditions in clayey sequences. *Geol. Geophys.*, 11: 18–26.
- Bolshakov, Yu. Ya. and Cherenkov, S. B., 1989. Systems analysis of interaction between geologic and capillary processes, and new properties of hydrocarbon distribution in Siberian oil- and gas-bearing rocks. *The III All-Union Conference "Systems Approach in Geology"*, Moscow, pp. 21–22.
- Bordovskiy, O. K., 1974. *Organic Matter in Marine and Oceanic Deposits During Diagenesis*. Nauka Press, Moscow, 296 pp.
- Brod, I. O., 1947. On hydrocarbon fluid migration in the Earth's crust. *Proc. USSR Acad. Sci., Geol. Ser.*, 4: 75–79.
- Brod, I. O. and Eremenko, N. A., 1950. *Basics of Oil and Gas (Brief Course)*. Moscow State University Publishing, 245 pp.
- Brod, I. O., 1957. *Oil and Gas Accumulations (Formation and Classification)*. Gostoptechizdat, Moscow, 305 pp.
- Burlin, Yu. K., 1986. Systems approach to studies of oil and gas-generation. In: *Methodological Problems of Oil and Gas, and their Practical Applications*. Novosibirsk, pp. 153–158.
- Burst, T. F., 1969. Diagenesis of Gulf Coast clay sediments and its possible relation to petroleum migration. *Bull. Am. Assoc. Petrol. Geol.*, 1: 73–94.
- Buryakovskiy, L. A., 1968. Entropy as criterion of heterogeneity of rocks. *Int. Geol. Rev.*, 10(7): 761–764.
- Buryakovskiy, L. A., 1974. Distribution pattern of oil and gas deposits within the Absheron Archipelago. *Int. Geol. Rev.*, 16(7): 749–758.
- Buryakovskiy, L. A., Listengarten, B. M. and Bairamalibeli, N. I., 1974. Correlation of conjugated petrophysical and geochemical parameters of oil and gas reservoirs (Azeri and English summary). *Proc. Azerbaijan Acad. Sci., Earth's Sci. Ser.*, (5): 80–88.
- Buryakovskiy, L. A. and Kukhmazov, M. S., 1975. Classification of sandy-silty-clayey rocks based on petrography and reservoir indexes. *Petrol. Geol.*, 13(3): 125–129.

- Buryakovskiy, L. A. and Dzhaferov, I. S., 1980. Permeability anisotropy in stratified oil- and gas-bearing rocks. *Int. Geol. Rev.*, 22(9): 1067–1069.
- Buryakovskiy, L. A., Dzhaferov, I. S., Dzhevanshir, R. D. and Kuzmina-Gerasimova, V. L., 1981. Simulation of physical properties of reservoir and sealing rocks in deposits of oil and gas. *Proc. International Symposium COGEO DATA on the Computerizing of Geological Data*, pp. 26–27.
- Buryakovskiy, L. A., Dzhaferov, I. S. and Dzhevanshir, R. D., 1982. *Prediction of Petrophysical Properties of Oil and Gas Reservoirs and Seals*. Nedra Press, Moscow, 200 pp.
- Buryakovskiy, L. A. and Dzhaferov, I. S., 1984. Informational simulation of the process of geologic system cognition (Azeri and English summary). *Proc. Azerbaijan Acad. Sci., Earth's Sci. Ser.*, 1: 34–40.
- Buryakovskiy, L. A., 1985a. Dynamic stochastic models of geologic systems (Azeri and English summary). *Proc. Azerbaijan Acad. Sci., Earth's Sci. Ser.*, 5: 44–51.
- Buryakovskiy, L. A., 1985b. *Petrophysics of Oil and Gas Reservoir Rocks of the Productive Series of Azerbaijan*. Elm Press, Baku, 196 pp.
- Buryakovskiy, L. A. and Dzhevanshir, R. D., 1985. Structure of pore space in Cenozoic argillaceous rocks of Azerbaijan in connection with development in them of abnormal pore pressure. *Lithol. Mineral Resour.*, 20(1): 83–91.
- Buryakovskiy, L. A., 1986. Dynamic stochastic models as the basis of the systems forecast in geosciences. *The III All-Union Conference on Systems Approach to Geological Studies*, Moscow Institute of Oil and Gas Industry.
- Buryakovskiy, L. A., Arkharova, I. M. and Agamaliyev, R. A., 1986. Surface-active properties of rocks in the Productive Strata of Azerbaijan. *Proc. of the II Symp. on Mining Chemistry*, Visegrád, Hungary, pp. 139–149.
- Buryakovskiy, L. A., Dzhevanshir, R. D. and Aliyev, R. Yu., 1986. *Well-logging Techniques in Studying Formation Pressures*. Elm Press, Baku, 148 pp.
- Buryakovskiy, L. A., Dzhevanshir, R. D., Kheirov, M. B. and Aliyev, R. Yu., 1988. Post-sedimentary transformation of Middle Pliocene clay minerals of the South Caspian depression. *Lithol. Mineral Resour.*, 23(1): 68–77.
- Buryakovskiy, L. A. and Agamaliyev, R. A., 1990. *Textbook on Application of Mathematical Methods in Geochemistry and Hydrochemistry*. Azerbaijan Institute of Oil and Chemistry Publishing, 140 pp.
- Buryakovskiy, L. A., Dzhaferov, I. S. and Dzhevanshir, R. D., 1990. *Mathematical Modeling of Petroleum Geology Systems*. Nedra Press, Moscow, 295 pp.
- Buryakovskiy, L. A., Dzhaferov, I. S. and Kerimov, V. Yu., 1991. *Exploration for Marine Oil and Gas Fields*. Nedra Press, Moscow, 260 pp.
- Buryakovskiy, L. A. and Chilingarian, G. V., 1991. Time factor in mathematical models of geologic and technical processes. *J. Petrol. Sci. Engr.*, 6: 341–347.
- Buryakovskiy, L. A., 1992. Scientific bases, methods and results of mathematical simulation and prediction of structure and behavior of petroleum geology systems. *Energy Sources*, 14: 273–295.
- Buryakovskiy, L. A. and Dzhevanshir, R. D., 1992. Mathematical models of interconnections between composition and properties of oil in the Apsheron oil- and gas-bearing region of Azerbaijan. *Energy Sources*, 14: 51–71.
- Buryakovskiy, L. A., 1993a. Method and software for numerical simulation of reservoir properties of oil- and gas-bearing rocks. *Comput. Geosci.*, 19(6): 803–815.
- Buryakovskiy, L. A., 1993b. Outline of general and petroleum geology in Azerbaijan and the South Caspian Basin. *Bull. Houston Geol. Soc.*, 35(6): 16–23, 43–47.
- Buryakovskiy, L. A., Dzhevanshir, R. D. and Chilingar, G. V., 1995. Abnormally high formation pressures in Azerbaijan and the South Caspian Basin (as related to smectite \Leftrightarrow illite transformations during diagenesis and catagenesis). *J. Petrol. Sci. Engr.*, (13): 203–218.
- Buryakovskiy, L. A., Chilingar, G. V. and Aminzadeh, F., 2001. *Petroleum Geology of the South Caspian Basin*. Gulf Professional Publishing/Butterworth-Heinemann/Reed Elsevier Group, Woburn, MA, 442 pp.
- Buryakovskiy, L. A., Dzhevanshir, R. D., Chilingar, G. V., et al., 2002. Smectite-illite transformation during diagenesis and catagenesis as related to overpressures. In: *Origin and Prediction of Abnormal Formation Pressures, Developments in Petroleum Science*, 50, Elsevier, Amsterdam, pp. 97–122.

- Buryakovskiy, L. A., Chilingar, G. V. and Robertson, J. O. Jr., 2004. Axiomatic approach to the geological and geophysical sciences, *Energy Sources*, 26(6): 575–593.
- Capiano, R. M., 1993. Evidence of fluid flow in microfractures in geopressed shales. *Bull. Am. Assoc. Petrol. Geol.*, 77(8): 1303–1314.
- Cartmill, J. C., 1979. Obscure nature of petroleum migration and entrapment. *Bull. Am. Assoc. Petrol. Geol.*, 60(9): 98–103.
- Chakhmakhchev, V. A., 1982. *Geochemistry of Migration Process in Hydrocarbon Systems*. Nedra Press, Moscow, 231 pp.
- Chapman, R. E., 1981. *Geology and Water. An Introduction to Fluid Mechanics for Geologists*. Nijhoff/Junk, The Hague, 228 pp.
- Chapman, R. E., 1983. *Petroleum Geology*. Elsevier, Amsterdam, 415 pp.
- Chave, K. E., 1960. Evidence on history of seawater from chemistry of deeper subsurface waters of ancient basins. *Bull. Am. Assoc. Petrol. Geol.*, 44: 357–370.
- Chebotarev, I. I., 1955. Metamorphism of natural waters in the crust of weathering, 1–3. *Geochim. Cosmochim. Acta*, 8: 22–48, 137–170, 198–212.
- Chekalyuk, E. B. and Filos, Yu. I., 1977. *Oil–Water Solutions*. Naukova Dumka Press, Kiev, 147 pp.
- Chekalyuk, E. B., 1986. To an issue of oil synthesis at great depths. *ZhVKhO Publishing*, 31: 556–561.
- Chen, J. C. and Fang, J. H., 1993. A new method for prospect appraisal. *Bull. Am. Assoc. Petrol. Geol.*, 77(1): 9–18.
- Chepak, G. N., 1984. Oil accumulations as intermediate form of its primary migration. *Oil Gas Geol., Geophys. Drilling*, 7: 3–6.
- Chilingar, G. V., 1956. Durov's classification of natural waters and chemical composition of atmospheric precipitation in USSR. *Trans. Am. Geophys. Union*, 37(2): 193–196.
- Chilingar, G. V., 1957. Soviet methods of reporting and displaying results of chemical analyses of natural waters and methods of recognizing oil-field waters. *Trans. Am. Geophys. Union*, 38(2): 219–221.
- Chilingar, G. V., 1958. Chemical composition of oil-field waters from Apsheron Peninsula, Azerbaijan S.S.R.: A summary. *Geochim. Cosmochim. Acta*, 14: 168–172.
- Chilingar, G. V. and Degens, E. T., 1964. Notes on chemistry of oil-field waters. *Bol. Asoc. Mexicana Geol. Petrol.*, 15(7–8): 177–193.
- Chilingar, G. V., Main, R. and Sinnokrot, A., 1963. Relationship between porosity, permeability, and surface area of sediments. *J. Sediment. Petrol.*, 33(3): 759–765.
- Chilingar, G. V., Mannon, R. W. and Rieke, H. H., 1972. *Oil and Gas Production from Carbonate Rocks*. Elsevier, New York, 408 pp.
- Chilingarian, G. V. and Wolf, K. H., 1975. *Compaction of Coarse Grained Sediments, Part I: Developments in Sedimentology*, 18A. Elsevier, Amsterdam, 552 pp.
- Chilingarian, G. V. and Wolf, K. H., 1976. *Compaction of Coarse Grained Sediments, Part II: Developments in Sedimentology*, 18B. Elsevier, Amsterdam, 808 pp.
- Chilingarian, G. V. and Rieke, H. H. III, 1976. Compaction of argillaceous sediments. In: W. H. Fertl (Ed.), *Abnormal Formation Pressures. Development in Petroleum Science*, 2. Elsevier, Amsterdam, pp. 49–100.
- Chilingar, G. V., Bissell, H. J. and Wolf, K. H. 1979. *Diagenesis of Carbonate Sediments and Epigenesis (or Catagenesis) of Limestones* In: *Diagenesis in Sediments and Sedimentary Rocks. Developments in Sedimentology*, 25A, Elsevier, Amsterdam, pp. 247–422.
- Chilingar, G. V. and Degens, E. T., 1964. Notes on chemistry of oilfield waters. *Bol. Asoc. Mexicana Geol. Petrol.*, 15 (7–8): 177–193.
- Chilingar, G. V., Serebryakov, V. A. and Robertson, J. O. Jr., 2002. *Origin and Prediction of Abnormal Formation Pressures. Developments in Petroleum Science*, 50, Elsevier, Amsterdam, 373 pp.
- Chilingarian, G. V., Robertson, J. O. and Kumar, S., 1988. *Surface Operations in Petroleum Production, Part I: Developments in Petroleum Science*, 19A. Elsevier, Amsterdam, 821 pp.
- Chilingarian, G. V., Robertson, J. O. and Kumar, S., 1989. *Surface Operations in Petroleum Production, Part II: Developments in Petroleum Science*, 19B. Elsevier, Amsterdam, 562 pp.
- Chilingarian, G. V., Jincai Chang and Bagrintseva, K. I., 1990. Empirical expression of permeability in terms of porosity, specific surface area, and residual water saturation of carbonate rocks. *J. Petrol. Sci. Engr.*, 4: 317–322.

- Chilingarian, G. V., Mazzullo, S. J. and Rieke, H. H., 1992. *Carbonate Reservoir Characterization: A Geologic — Engineering Analysis, Part I: Developments in Petroleum Science*, 30. Elsevier, Amsterdam, 639 pp.
- Chilingarian, G. V., Rieke, H. H., and Kazi, A., 1994. Chemistry of pure water. In: *Studies in Abnormal Pressures*, W. H. Fertl, R. E. Chapman, and R. F. Hotz (Editors), Elsevier, Amsterdam, pp. 107–153.
- Chilingarian, G. V., Mazzullo, S. J. and Rieke, H. H., 1996. *Carbonate Reservoir Characterization: A Geologic-Engineering Analysis, Part II: Developments in Petroleum Science*, 44. Elsevier, Amsterdam, 994 pp.
- Chung, H. M., Claypool, G. E., Rooney, M. A. and Squires, R. M., 1994. Source characteristics of marine oils as indicated by carbon isotope ratios of volatile hydrocarbons. *Bull. Am. Assoc. Petrol. Geol.*, 78(3): 396–408.
- Conteharu, H. M. and Boudjema, A., 1993. Maturity and geochemical classification of Algerian oils. *Poster sessions from the XVI International Meeting on Organic Geochemistry*, Stavanger, pp. 261–264.
- Crovelli, R. A., 1987. Probability theory versus simulation of petroleum potential in play analysis. *Statistical and Computational Problems in Probability Modeling, Part 1*. pp. 363–381.
- Degens, E. T., Pierce, W. D. and Chilingar, G. V., 1962. Origin of petroleum-bearing freshwater concretions of Miocene age. *Bull. Am. Assoc. Petrol. Geol.*, 62(8): 1522–1527.
- Degens, E. T., Chilingar, G. V. and Pierce, W. D., 1963. On the origin of petroleum inside freshwater carbonate concretions of Miocene age. *Advances in Organic Geochemistry, Proc. Internat. Meet.*, Milan, pp. 1–16.
- Degens, E. T. and Chilingar, G. V., 1967. Diagenesis of subsurface waters. In: G. Larsen, and G. V. Chilingar (Eds.), *Diagenesis in Sediments: Developments in Sedimentology*, 8, Elsevier, Amsterdam.
- De Sitter, L. U., 1947. Diagenesis of oil-field brines. *Bull. Am. Assoc. Petrol. Geol.*, 31: 2030–2040.
- Dickey, P. A., 1975. Possible primary migration of oil from source rock as oil phase. *Bull. Am. Assoc. Petrol. Geol.*, 59(2): 336–345.
- Dickinson, G., 1953. Geological aspects of abnormal reservoir pressures in Gulf Coast, Louisiana. *Bull. Am. Assoc. Petrol. Geol.*, 37: 410–432.
- Dmitriyevskiy, A. N., 1982. *Lithogenetic Systems Analysis of Oil and Gas Basins*. Nedra Press, Moscow, 177 pp.
- Dmitriyevskiy, A. N., 1984. System-structural analysis of oil and gas basins. In: *Systems Studies in Geology of Caustobioliths*. Nauka Press, Moscow, pp. 33–38.
- Dmitriyevskiy, A. N., 1986. *Major Principles of Natural/Goal Oriented Approach in Geology and Methodological Grounds of Systems-geologic Studies in Geology and Geophysics*. Nauka Press, Novosibirsk.
- Dmitriyevskiy, A. N., Bazhenova, T. K., Ilyukhin, L. H. et al., 1992. *Siberian Platform Sedimentary Basin Evolution in Vendian-Paleozoic and Forecast of their Hydrocarbon Potential*. Federal Gas Concern, Moscow, 57 pp.
- Dmitriyevskiy, A. N., 1993. Systems approach in oil and gas geology, general concepts in studies of systems approach in geology. *Geol. Oil Gas*, 10: 2–4.
- Dmitriyevskiy, A. N., Samsonov, Yu. V., Ilyukhin, L. H. et al., 1993. *Oil and Gas Accumulation Zones in Carbonate Sediments of Siberian Platform*. Nedra Press, Moscow, 119 pp.
- Dmitriyevskiy, A. N., 1994. Systems approach to the development of theory and techniques in forecasting oil and gas occurrences in the subsurface. *Geol. Oil Gas*, 2: 2–4.
- Dobrynin, V. M., 1970. *Deformation and Alteration of Physical Properties of Oil and Gas Bearing Reservoir Rocks*. Nedra Press, Moscow.
- Dobrynin, V. M. and Serebryakov, V. A., 1989. *Geologic and Geophysical Methods for Prediction of Abnormal Formation Pressures*. Nedra Press, Moscow, 287 pp.
- Dobrynin, V. M. and Kuznetsov, O. L., 1993. *Thermoelastic Processes in Rock of Sedimentary Basins*. Proc. VNII Geosystem, Moscow, 176 pp.
- Dolton, G. L., Bird, K. S. and Crovelli, R. A., 1987. Assessment of in-place oil and gas resources: Petroleum Geology of the Northern Part of the ANWR, NE Alaska, *USGS Bull.*, 1178: 277–298.
- Domine, F., 1991. High-pressure pyrolysis of *n*-hexane, 2,4-dimethylpentane and 1-phenylbutane: Is pressure an important geochemical parameter? *Org. Geochem.*, 17(5): 619–634.

- Donofrio, R. R., 1981. Impact craters: Implications for basement hydrocarbon production. *J. Petrol. Geol.*, 3(3).
- Dow, W. G., 1977. Kerogen studies and geological interpretations. *Geochem. Explor.*, 7: 79–99.
- Drew, L. J. and Schuenemeyer, J. H., 1993. The evolution and use of discovery process models at the U.S. Geological Survey. *Bull. Am. Assoc. Petrol. Geol.*, 77(3): 467–478.
- Durmishyan, A. G., 1973. On the consolidation of argillaceous rocks. *Proc. USSR Acad. Sci., Geology Ser.*, 8: 85–89.
- Durov, S. A., 1948. Classification of natural waters and graphical presentation of their composition. *Trans. USSR Acad. Sci.*, 59(1): 87–90.
- Dutton, S. P. and Diggs, T. N., 1992. Evolution of porosity and permeability in the Lower Cretaceous Travis Peon Formation, East Texas. *Bull. Am. Assoc. Petrol. Geol.*, 76(2): 252–269.
- Efros, A. L., 1982. *Physics and Geometry of Chaos*. Nauka Press, Moscow.
- Einstein, A., 1965. *Physics and Reality*. Nauka Press, Moscow.
- Eremenko, N. A., Maksimov, S. P. and Tkhostov, B. A., 1949. On bitumen-formation cycles in the NE Caucasus. *Oil Econ.*, 12: 9–12.
- Eremenko, N. A. (Ed.), 1960. *Geology of Petroleum, I — Principles of Geology and Petroleum*. Gostoptekhizdat, Moscow, 592 pp.
- Eremenko, N. A. and Ul'yanov, A. V., 1960. Oil and gas-bearing sequences of the world, their features and distribution. *Regional and Structural Problems of Petroleum Geology. Proc. XXI International Geologic Congress*, Moscow, pp. 19–21.
- Eremenko, N. A., 1968. *Geology of Oil and Gas*. Nedra Press, Moscow, 389 pp.
- Eremenko, N. A. and Neruchev, S. G., 1968. Primary migration during burial and lithogenesis of sediments. *Geol. Oil Gas*, 9: 28–32.
- Eremenko, N. A., Ammosov, I. I., Petrov, A. A. et al., 1976. Interrelation of mineral and organic components at different stages in the formation of oil and gas-bearing sequences. *Proc. XXV International Geologic Congress*, Moscow, pp. 117–152.
- Eremenko, N. A., Mikhaylov, I. M. and Yakovlev, B. M., 1978. Role of hydraulic forces in the preservation of non-anticlinal oil and gas accumulations. *Proc. IGIRGI*, 17: 21–33.
- Eremenko, N. A. and Tverdov, R. A., 1980. Sorbed hydrocarbons in dispersed organic matter. *Geol. Oil Gas*, 12: 26–31.
- Eremenko, N. A., 1984. Oil and gas fields and their classification. *Reference Book on Geology of Oil and Gas*. Nedra Press, Moscow, pp. 227–234.
- Eremenko, N. A., 1985. Primary accumulation in oil source-rocks. *Geol. Oil Gas*, 2: 14–18.
- Eremenko, N. A., 1986. Methodological bases of the development of theory of oil and gas origin. In: *Methodological Problems of Oil and Gas Geology and their Practical Applications*. Nauka Press, Novosibirsk, pp. 71–83.
- Eremenko, N. A., Maksimov, S. P. and Minskiy, N. A., 1986. *Lithologic factors in oil-gas-generation and oil-gas-accumulation at great depths (Abstract)*. Moscow State University Press, Moscow, pp. 17–19.
- Eremenko, N. A. and Chilingarian, G. V. (Eds.), 1991. *Petroleum Geology Handbook*. OSI Publications, Los Angeles, CA, 600 pp.
- Eremenko, N. A. and Chilingar, G. V., 1996. *Geology of Oil and Gas*. Nauka Press, Moscow, 176 pp.
- Espitalie, J., Laporte, J. L., Madec, M. et al., 1977. Methode rapide caracterisation de roches meres, de leur potentiel petrolier et de leur degre d'evolution. *Rev. Inst. Fr. Petrol.*, 32: 23–42.
- Fertl, W. H., 1976. *Abnormal Formation Pressure. Developments in Petroleum Science*, 2. Elsevier, Amsterdam, 382 pp.
- Fertl, W. H., Chapman, R. E. and Hotz, R. F. (Eds.), 1994. *Studies in Abnormal Pressures, Developments in Petroleum Science*, 38. Elsevier, Amsterdam, 454 pp.
- Fotiadi, E. E. and Voronin, Yu. A. (Eds.), 1967. *Geology and Mathematics*. Nauka Press, Novosibirsk, 253 pp.
- Freund, H. and Kelemen, S. R., 1989. Low-temperature pyrolysis of Green River kerogen. *Bull. Am. Assoc. Petrol. Geol.*, 73(8): 1011–1017.
- Fyodorov, S. F., 1962. Gradual migration of oil and gas. *Sov. Geol.*, 7: 8–26.

- Gadzhi-Kasumov, A. S., 1985. Some theoretical problems of oil and gas generation. *Problems in the Theory and Methodology in Forecasting Oil and Gas Occurrences in the Subsurface*. Oil and Gas, Moscow, pp. 82–100.
- Galimov, E. M., 1973. On new model of oil-gas-generation process. *Nature of Organic Matter in Modern and Fossil Sediments*, Nauka Press, Moscow.
- Gattenberger, Yu. P., 1984. Techniques of hydrodynamic studies in oil-gas-bearing basins. *Reference Book on Geology of Oil and Gas*. Nedra Press, Moscow, pp. 312–328.
- Gavrilov, V. P., 1993. New geodynamic approaches to the evolution of lithosphere and problems of oil and gas-generation. In: *Problems in the Theory and Methodology in Forecasting Oil and Gas Occurrences in the Subsurface*. Oil and Gas, Moscow, pp. 100–114.
- Genik, G. J., 1993. Petroleum geology of Cretaceous-Tertiary rift basins in Niger, Chad and Central African Republic. *Bull. Am. Assoc. Petrol. Geol.*, 77(8): 605–624.
- Geodekyan, A. A., Yegorov, A. E. and Yentov, V. M., 1984. On HC migration via isothermal distillation. *Trans. USSR Acad. Sci.*, 7(1): 170–173.
- Glesstone, S., Leidler, K. and Airing, T., 1948. *Theory of Absolute Velocity of Reactions*. Publishing House for Foreign Literature, Moscow.
- Golovachev, E. M., 1984. Systems approach to petroleum geology, object's rank, scale of its study, and forecast level. *Systems Studies in Geology of Caustobioliths*. Nauka Press, Moscow, pp. 38–42.
- Goncharov, I. V., 1987. *Oil Geochemistry in West Siberia*. Nauka Press, Moscow, 125 pp.
- Gorrell, H. A., 1958. Classification of formation waters based on sodium chloride content. *Bull. Am. Assoc. Petrol. Geol.*, 42: 2513.
- Gorskaya, A. I., 1950. Studies of organic matter in modern deposits. *Cognition of Modern Analogues of Oil-Gas-Bearing Facies*. Gostoptekhizdat, Moscow, 96 pp.
- Gottikh, R. P. and Pisotskiy, B. I., 1986. On one form of hydrocarbon migration. *The II All-Union Meeting on Carbon Geochemistry*, Moscow, pp. 343–345.
- Gretnener, P. E., 1969. Fluid pressure in porous media — its importance in geology. A review. *Bull. Can. Petrol. Geol.*, 17(3): 245–255.
- Gubkin, I. M., 1915. Geologic studies in the Kuban oil region. *Proc. Geologic Committee, New Series*, Issue 115.
- Gubkin, I. M., 1932. *Science of Oil*. OHTII, Moscow.
- Gussow, W. C., 1954. Differential entrapment of oil and gas: a fundamental principle. *Bull. Am. Assoc. Petrol. Geol.*, 38(5): 816–853.
- Gussow, W. C., 1968. Migration of reservoir fluids. *J. Petrol. Technol.*, 20(4): 353–363.
- Halbouty, M. T., 1970. Geology of giant petroleum fields. *Mem. Am. Assoc. Petrol. Geol.*, 14: 575.
- Hall, A. D. and Feigin, R. E., 1969. Definition of the concept of system. *Studies in General Theory of Systems*. Progress Press, Moscow, pp. 252–282.
- Harbaugh, J. W. and Bonham-Carter, G., 1974. *Computer Simulation in Geology*. Mir Press, Moscow.
- Hedberg, H. D., 1926. The effect of gravitational compaction on the structure of sedimentary rocks. *Bull. Am. Assoc. Petrol. Geol.*, 10(10): 1035–1072.
- Hnatiuk, J. and Martinelli, J. W., 1967. The relationship of the Westrose D-3 Pool to other pools on the common aquifer. *J. Can. Petrol. Technol.*, April–May: 43–49.
- Hoering, T. and Moore, H., 1958. The isotopic composition of the nitrogen in natural gases and associated crude oils. *Geochim. Cosmochim. Acta*, 13(4): 225–232.
- Honarpour, M. M., Chilingarian, G. V. and Mazzullo, S. J., 1992. Permeability and relative permeability of carbonate reservoirs (pp. 399–416). In: G. V. Chilingarian, S. J. Mazzullo and H. H. Rieke (Eds.), *Carbonate Reservoir Characterization: A Geologic Engineering Analysis, Part I*. Elsevier, Amsterdam, 639 pp.
- Horsefield, R., 1962. Performance of the Leduc D-3 reservoir. *SPE Petrol. Trans. Reprint Ser.*, (4): 65–72.
- Houghton, J. C., 1988. The use of the truncated shifted Pareto distribution in assessing the size distribution of oil and gas fields. *Math. Geol.*, 20(8): 907–938.
- Houghton, J. C., Dolton, G. L., Mast, R. F. et al., 1993. U.S. Geological Survey estimation procedure for accumulation size distribution by play. *Bull. Am. Assoc. Petrol. Geol.*, 77(3): 454–466.

- Hubbert, M. K. and Rubey, W. W., 1959. Role of fluid pressure in mechanics of overthrust faulting. *Geol. Soc. Am. Bull.*, 70(2): 167–206.
- Hunt, J. M., 1979. *Petroleum, Geochemistry and Geology*. Freeman, San Francisco, 675 pp.
- Hunt, J. M., 1981. Distribution of hydrocarbons in sedimentary rocks. *Geochim. Cosmochim. Acta*, 22: 37–49.
- Ignatchenko, N. A., 1968. Earthquake effect on rock formation conditions. *Lithol. Mineral Resour.*, 2: 7–11.
- Ilich, H. A., 1983. Pristane, phitane and lower molecular weight isoprenoid distributions in oils. *Bull. Am. Assoc. Petrol. Geol.*, 67(3): 385–393.
- Il'inskaya, V. V., 1985. *Genetic Relation between the Hydrocarbons of Organic Matter of Rocks and Oil*. Nedra Press, Moscow, 175 pp.
- Il'inskaya, V. V. and Tukh, M. P., 1985. Inherited structures in heavy and sulfur-rich oils. In: *Distribution and Generation Conditions of Heavy and Sulfur-Rich Oils*. Nauka Press, Moscow, pp. 33–37.
- Il'inskaya, V. V., 1986. *Principles of Identifying Qualitative and Quantitative Genetic Relation between Oils and Organic Matter of Sedimentary Rocks*. Nauka Press, Moscow, 229 pp.
- Izosimova, A. N. and Chalaya, O. N., 1989. *Relic Hydrocarbons in Organic Matter of the West Yakutia Subsurface*. Nauka Press, Novosibirsk.
- Karogodin, Yu. N. and Prokopenko, A. I., 1984. *Study Techniques of Oil and Gas Basin Structure*. Nedra Press, Moscow, 97 pp.
- Karimov, I. A. and Kalapov, M. U., 1983. X-ray/neutron study of insoluble OM in sedimentary rocks. *Trans. Uzbek Acad. Sci.*, 3: 15–20.
- Kartsev, A. A., 1984. Geochemistry of oil and gas accumulations. *Reference Book of Oil and Gas Geology*. Nedra Press, Moscow, pp. 376–388.
- Kartsev, A. A. and Ilyukhin, L. N., 1990. Interbed fluid cross-flow as indication of oil-gas occurrence. *Summary Reviews of VNIIEgazprom*, Moscow, pp. 7–8.
- Kedrov, B. M., 1980. On modern classification of sciences. *Philosophic Issues*, 10: 85–103.
- Kerans, C., Lucia, F. J. and Senger, R. K., 1994. Integrated characterization of carbonate ramp reservoirs using Permian San Andreas formation outcrop analogs. *Bull. Am. Assoc. Petrol. Geol.*, 78(2): 181–216.
- Khain, V. Ye., 1973. *Geotectonic Bases for Oil Field Exploration*. Aznefteizdat Publ. House, Baku.
- Khaken, G., 1985. *Synergetics. Hierarchies of Instability in Self-Organizing Systems and Devices*. Mir Press, Moscow, 423 pp.
- Khakimov, E. M., 1986. *Modeling of Hierarchic Systems*. Kazan University Publishing, 160 pp.
- Khanin, A. A., 1976. *Petrophysics of Oil and Gas Reservoir Rocks*. Nedra Publ. House, Moscow, 304 pp.
- Khilyuk, L.F., Chilingar, G.V., Robertson, J.O., Jr., and Endres, B., 2000. *Gas Migration, Events Preceding Earthquakes*. Gulf Publ. Co., Houston, TX, 389 pp.
- Klubova, T. T., 1973. *Clay Minerals and their Role in the Genesis, Migration and Accumulation of Oil*. Nedra Press, Moscow, 209 pp.
- Klubova, T. T., 1975. On structural features of clay rocks determining their role in the formation of oil and gas accumulations. *Problems Petrol. Geol., Moscow*, 5: 106–111.
- Klubova, T. T., 1984. Oil and gas sequences. *Reference Book of Oil and Gas Geology*. Nedra Press, Moscow, pp. 142–205.
- Kovalev V. P., 1986. Methodological requirements for adequate representation of complex natural systems by the geologic science. In: *Methodological Studies in Geology and Geophysics*. Nauka Press, Novosibirsk, pp. 6–32.
- Kozlov, A. L., 1940. *Problems of Natural Gas Geochemistry and Genesis of Accumulations*. ONTI, Moscow, 69 pp.
- Komarov, V. E., 1984. Time issue in geology. In: *Systems Studies in Geology of Caustobioliths*. Nauka Press, Moscow, pp. 162–181.
- Kontorovich, A. E., Bogorodskaya, L. I. and Melnikova, V. M., 1974. Anaerobic transformations of organic matter in ancient marine deposits. *Proc. USSR Acad. Sci., Geol. Ser.*, (3): 112–123.
- Kontorovich, A. E., Nesterov, I. I., Salmanov, F. K. et al., 1975. *Geology of Oil and Gas in West Siberia*. Nedra Press, Moscow, 521 pp.

- Kontorovich, A. E., 1976. Some problems of oil genesis and geochemical history in the West Siberian Plain. In: *Patterns in Distribution and Conditions of Formation of Oil and Gas Fields in the West Siberian Plain*. Nedra Press, Moscow, pp. 91–108.
- Kontorovich, A. E., 1991. General theory of naphtidogenesis. In: *Theoretical and Regional Problems of Petroleum Geology*. Nauka Press, Novosibirsk, pp. 29–44.
- Korchagina, Yu. I., Ivanov, M. K., Chilingar, G. V. and Yen, T. F., 1988. Major stages of transformation of dispersed organic matter. *Energy Sources*, 10(1): 21–42.
- Koshmann, J. J., 1985. Geologic time as a parameter in organic metamorphism and vitrinite reflectance as an absolute paleogeothermometer: Discussion. *J. Petrol. Geol.*, 8(2): 228–232.
- Kosygin, Yu. A. and Solovyev, V. A., 1969. Static, dynamic and retrospective systems in geologic studies. *Proc. USSR Acad. Sci., Geol. Ser.*, 6: 9–17.
- Kosygin, Yu. A., 1978. *Hierarchy of Geologic Bodies*. Khabarovsk.
- Kram, I. Kh., 1974. *Prospective Oil and Gas Provinces of the USA*. Nedra Press, Moscow, 632 pp.
- Krasny, L. I., 1989. Tectonic Systematic (Contemporary Problems). *Abstracts of the III All-Union Conference "Systems Approach to Geology"*, Moscow.
- Krouse, H. R., Vian, Ch. A., Eliak, L. S., 1988. Chemical and isotopic coincidence of thermochemical sulfate reduction by light hydrocarbon gases in deep carbonate reservoirs. *Nature*, 33: 415–419.
- Krejci-Graf, F., Hecht, F. and Palsler, W., 1957. Uber Olfeldwasser des Wiener Beckens. *Geol. Jahrb.* 74: 161–209.
- Kruglikov, N. I., 1976. On the film-type migration of oil. In: *Problems of Geofluidal Dynamics*. VNIGRI, Leningrad, pp. 103–107.
- Krumbein, W. C. and Graybill, K. A., 1969. *An Introduction to Statistical Models in Geology* (translated from English). Mir Press, Moscow.
- Krumbein, W. C., Kauffman, M. E. and McCammon, R. B., 1973. *Models of Geological Processes. An Introduction to Mathematical Geology* (translated from English). Mir Press, Moscow.
- Krut', I. V., 1973. *Studies in Foundations of Theoretical Geology*. Institute for History of Natural Sciences and Technology, Nauka Press, Moscow, 206 pp.
- Kurazhkovskaya, E. A., 1970. *Dialectic Concept of Evolution in Geology (Philosophical Aspect)*. Moscow State University Publishing, Moscow, 240 pp.
- Kuznetsov, V. G., 1992. *Oil and Gas Reservoirs in Carbonates*. Nedra Press, Moscow, 191 pp.
- Langnes, G. L., Robertson, J. O. and Chilingar, G. V., 1972. *Secondary Recovery and Carbonate Reservoirs*. Elsevier, New York, 304 pp.
- Lapinskaya, T. A. and Postnikov, A. V., 1993. On the problems of geodynamic evolution of an ancient platform. In: *Problems of Theory and Methodology in Forecasting Oil and Gas Occurrences in the Subsurface*. Oil and Gas, Moscow, pp. 114–130.
- Larsen, G. and Chilingar, G. V., 1967. *Diagenesis in Sediments*. In: *Developments in Sedimentology*, 8, Elsevier, Amsterdam, 551 pp.
- Larskaya, E. S., 1983. *Diagnostics and Study Techniques of Source Rocks*. Nedra Press, Moscow, 211 pp.
- Law, B. E. and Dickinson, W. W., 1985. Conceptual model for origin of abnormally pressured gas accumulations in low-permeability reservoirs. *Bull. Am. Assoc. Petrol. Geol.*, 69(8): 1217–1235.
- Law, B. E., Ulmishek, G. F. and Slavin, V. I. (Eds.), 1998. *Abnormal Pressures in Hydrocarbon Environments*. AAPG Memoir 70, Tulsa, OK, 264 pp.
- Lerche, I. and Yarzal, R. F., 1984. Determination of paleoheat flux from vitrinite reflectance data. *Bull. Am. Assoc. Petrol. Geol.*, 68(11): 976–1112.
- Leverett, M. C. and Lewis, W. B., 1940. Steady flow of gas–oil–water mixtures through unconsolidated sands. *AIME Tech. Pub.*, 1206 pp.
- Leverett, M. C., 1940. *Capillary Behavior in Porous Solids*. AIME Tech. Pub., p. 1223.
- Levorsen, A. I., 1967. *Geology of Petroleum*, 2nd ed.: Freeman, San Francisco, 724 pp.
- Lopatin, N. V., 1971. Temperature and geologic time as coalification factors. *Proc. USSR Acad. Sci., Geol. Ser.*, 2: 43–64.
- Lopatin, N. V., 1983. *Formation of Fossil Fuels*. Nedra Press, Moscow, 131 pp.

- Mackenzie, A. S., Patience, R. L., Maxwell, I. R. et al., 1980. Molecular parameters of maturation in the Toarcian shales, Paris Basin, France: Part 1. Changes in the configurations of acyclic isoprenoid alkanes, steranes and triterpanes. *Geochim. Cosmochim. Acta*, 44(11): 1709–1721.
- Magara, K., 1978. *Compaction and Fluid Migration: Practical Petroleum Geology*. Elsevier, Amsterdam, 319 pp.
- Magara, K., 1981. Possible primary migration of oil globules. *J. Petrol. Geol.*, 33: 325–331.
- Magara, K., 1982. *Rock Compaction and Fluid Migration* (translated from English). Nedra Press, Moscow, 227 pp.
- Maksimov, S. P., 1954. On the oil accumulation in the Carboniferous and Devonian deposits of the Samarskaya Luka area. *Oil Econ.*, 10: 40–47.
- Maksimov, S. P., Eremenko, N. A., Zhukhovitskiy, A. A. et al., 1959. Patterns in the changes of associated gas composition down the stratigraphic section. *Geol. Oil Gas*, 1: 4–17.
- Maksimov, S. P., 1962. Some regularities of the oil accumulation in the major oil and gas fields in the southern part of the Volga-Urals region. *Geol. of Oil Gas*, 1: 8–18.
- Maksimov, S. P., Botneva, T. A., Eremenko, N. A. et al., 1972a. On the cyclic nature of oil and gas generation processes. *Proc. XXIV International Geologic Congress*, Nauka Press, Moscow, pp. 117–127.
- Maksimov, S. P. and Minskiy, N. A., 1972b. On some geochemical causes affecting the distribution depths of major oil reserves. *Trans. USSR Acad. Sci.*, 204(6): 1225–1228.
- Maksimov, S. P., Kunin, N. Ya. and Sardonnikov, N. M., 1977. *Cyclicality of Geologic Processes and Problem of Oil/Gas Formation*. Nedra, Moscow.
- Maksimov, S. P., Botneva, T. A., Eremenko, N. A. et al., 1979. Organic matter and cyclic nature of the oil and gas generation processes. *Sov. Geol.*, 9.
- Marsden, S. S., 1968. Wettability: The elusive key to waterflooding. *Petrol. Engr.*, (Apr): 82–87.
- Massoud, M. S. and Kinghorn, R. F., 1985. A new classification of the organic components of kerogen. *J. Petrol. Geol.*, 8(1): 85–100.
- Masters, C. D., 1993. U.S. Geological Survey petroleum resource assessment procedures. *Bull. Am. Assoc. Petrol. Geol.*, 77(3): 452–453.
- Masters, I. A., 1979. Deep basin gas trap, Western Canada. *Bull. Am. Assoc. Petrol. Geol.*, 69(2): 267–293.
- Mekhtiev, Sh. F., 1956. *On the Origin of Oil and Formation of Petroleum Deposits in Azerbaijan*. Izd. Akad. Nauk of Azerbaijan S.S.R., Baku, 320 pp.
- Mileshina, A. G., Kalinko, M. K. and Safonova, G. I., 1983. *Alterations in Oils While Filtering Through Rocks*. Nedra Press, Moscow, pp. 75–81.
- Minskiy, N. A., 1975. *Formation of Oil-Bearing Rocks and Oil Migration*. Nedra Press, Moscow, 213 pp.
- Mirchink, M. F., Eremenko, N. A. and Klubov, V. A., 1976. Criteria of oil and gas zonation and oil and gas potential forecast. In: *Principles of Oil and Gas Zonation*. Nedra Press, Moscow, p. 171.
- Mikhaylov, I. M., 1984. Time, duration and formation rate of oil and gas accumulations. *Reference Book of Oil and Gas Geology*. Nedra Press, Moscow, pp. 414–423.
- Mikhaylovskiy, G., 1906. Some consideration on the origin of Caucasus oil. *Proc. Geol. Committee*, 25: 97–105.
- Miller, B. M., Thomsen, H. D., Dolton, G. et al., 1975. Geological estimates of undiscovered recoverable oil and gas resources in the United States. *USGS Circular*, 725: 78.
- Miller, B. M., 1981. Methods of assessing the petroleum reserves of Alaska. *Geology and Exploration of the National Petroleum Reserve in Alaska*. USGS Prof. Paper 1399: 117–128.
- Miller, R. L. and Kahn, J. S., 1965. *Statistical Analysis in the Geological Sciences* (translated from English). Mir Press, Moscow.
- Molchanov, V. I. and Gontsov, A. A., 1992. *Modeling of Oil and Gas Generation*. Nauka Press, Novosibirsk, 219 pp.
- Moskvin, V. I., 1981. Catagenesis of organic matter. *Geol. Oil Gas*, 3: 47–51.
- Movshovich, E. B., 1984. Systems approach to identification of oil and gas exploration targets. In: *Systems Studies in Geology of Caustobioliths*. Nauka Press, Moscow, pp. 107–136.
- Muravyov, I., Andriasov, R., Gimatudinov, Sh. and Polozkov, V., 1958. *Development and Exploration of Oil and Gas Fields*. Mir Publishers, Moscow, 503 pp. (in English).

- Mushin, I. A., Brodov, L. Yu., Kozlov, E. A. et al., 1990. *Structural Formational Interpretation of Seismic Data*. Nedra Press, Moscow, 151 pp.
- Nazarevich, B. P., Nazarevich, I. A. and Volkova, T. A., 1985. On a degree of matching in catagenesis of dispersed OM and thinly dispersed material in Aptian-Albian source-rocks of the Central and Eastern Fore-Caucasus. In: *Organic Matter in Modern and Fossil Deposits*. Nauka Press, Moscow, pp. 121–143.
- Nazarkin, L. A., 1979. *Effect of Deposition Rate and Erosion in Oil and Gas Basins*. Saratov University Publishing, Saratov (Russia), 157 pp.
- Nazarkin, L. A., 1994. *On Paleoclimatic and Dynamic Sedimentary Process of Oil and Gas Generation*. Saratov University Publishing, Saratov (Russia), 119 pp.
- Nametkin, S. S., 1955. *Chemistry of Oil*. The USSR Academy of Sciences Publishers, Moscow, 617 pp.
- Nelson, W.L., 1949. *Petroleum Refinery Engineering*. McGraw-Hill, New York, N.Y., 3rd ed., 830 pp.
- Neruchev, S. G., Rogozina, E. A. and Kapchenko, L. N., 1973. The main phase of gas formation — one of the stages in catagenetic evolution of sapropelic dispersed organic matter. *Geol. Geophys.*, 10: 14–16.
- Neruchev, S. G., 1979. Organic matter and accumulation of fossil fuels during Phanerozoic. *Trans. USSR Acad. Sci.*, 247(3): 117–118.
- Neruchev, S. G. and Rogozina, E. A., 1982. Quantitative assessment of oil and gas source-rock potential in sediments. Nauka Press, Moscow, pp. 26–34.
- Neruchev, S. G., Rogozina, E. A. et al., 1986. *Oil and Gas Generation in Domanik-Type Sediments*. Nedra Press, Leningrad, 133 pp.
- Neruchev, S. G. and Rogozina, E. A., 1992. General model of oil and gas generation in sedimentary rocks. In: *Oil and Gas Generation Models*. Nauka Press, Moscow, pp. 9–14.
- Neruchev, S. G., Chepak, G. N., Chistyakov, K. B. et al., 1992. *Oil and Gas Generation Models from OM in Oligocene Clays of the Eastern Stavropol Region in Conditions of Restricted and Free Fluid Outflow*. Nauka Press, Moscow, 91 pp.
- Nesterov, I. I. and Shpilman, V. I., 1984. *Oil and Gas Accumulation Theory*. Nauka Press, Moscow, 336 pp.
- Nesterov, I. I. and Ryl'kov, A. V., 1986. Evaluation of scale of generation and emigration of liquid and gaseous hydrocarbons. In: *Geochemistry of Processes of Generation and Accumulation of Hydrocarbons in Mesozoic Deposits of the Western Siberia*. Tyumen, pp. 3–19.
- Nesterov, I. I., Grigor'eva, G. F., Fishbein, Yu. V. et al., 1992. Thermodynamic aspects of hydrocarbon generation. In: *Oil and Gas Generation Models*. Nauka Press, Moscow, pp. 98–103.
- Novik, I. B., 1975. *Problems of Thinking Style in Sciences of Nature*. Politizdat, Moscow, 144 pp.
- Olenin, B. V., 1984. Classification of oil and gas basins, provinces and regions. In: *Reference Book of Oil and Gas Geology*. Nedra Press, Moscow, pp. 249–260.
- Otis, R. M. and Schneidermann, N., 1997. A process for evaluating exploration prospects. *Bull. Am. Assoc. Petrol. Geol.*, 81(7): 1087–1109.
- Perrodon, A., 1984. Le gas non-organique, mythe ou realite? *Gas Aujourd'hui*, 108 (2).
- Petrov, A. A., 1974. *Chemistry of Alcanes*. Nauka Press, Moscow, 379 pp.
- Petrov, A. A., 1984. *Hydrocarbons of Oil*. Nauka Press, Moscow, 419 pp.
- Petrov, A. A., 1985. Composition of biomarkers and biochemical indications of oil and gas generation processes. *Geol. of Oil Gas*, 10: 29–33.
- Philip, R. P., 1983. Correlation of crude oils from the San Jorge Basin, Argentina. *Geochim. Cosmochim. Acta*, 47: 267–275.
- Plotnikov, A. A., 1976. *Conditions for Formation of Hydrodynamic Traps*. Nedra Press, Moscow, 117 pp.
- Polishchuk, Yu. M. and Yashchenko, I. G., 2003. Cyclic character of changes in chemical properties of oils depending on age of rocks. *Geol. of Oil Gas*, 6: 53–57.
- Poston, S. W., Ysrael, S., Hossain, A. K. M. S., Montgomery, E. F. III. and Ramey, H. J. Jr., 1970. The effect of temperature on irreducible water saturation and relative permeability of unconsolidated sands. *Soc. Pet. Eng. J.*, 2: 171–180.
- Potonie, H., 1920. *Die Entstehung der Steinkohle und der Kaustobiolithe Uberhaupt*, 6. Aufl. B. Borntraeger, 139 pp.

- Powers, M. C., 1957. Fluid-release mechanisms in compacting marine mudrocks and their importance in oil exploration. *Bull. Am. Assoc. Petrol. Geol.*, 51: 1240–1254.
- Prasolov, E. M., 1990. *Isotope Geochemistry and the Origins of Natural Gases*. Nedra Press, Leningrad, 127 pp.
- Pratt, W. E., 1943. *Oil in the Earth*. Univ. Kansas Press, Lawrence, 231 pp.
- Price, L. C., 1973. *The Solubility of Hydrocarbons and Petroleum in Water as Applied to the Primary Migration of Petroleum*. Ph.D. Thesis, Geol. Univ. Calif., 15 pp.
- Price, L. C., 1982. Organic geochemistry of core samples from an ultradeep hot well (300°C, 7 km). *Chem. Geol.*, 37: 29–35.
- Price, L. C., 1983. Geologic time as a parameter of organic metamorphism and vitrinite reflectance as an absolute paleogeothermometer. *J. Petrol. Geol.*, 6: 5–38.
- Price, L. C., 1985. Geologic time as a parameter of organic metamorphism and vitrinite reflectance as an absolute paleogeothermometer (Reply). *J. Petrol. Geol.*, 8(2): 233–240.
- Price, L. C. and Barker, C. E., 1985. Suppression of vitrinite reflectance in amorphous rich kerogen — a major unrecognized problem. *J. Petrol. Geol.*, 8(1): 59–84.
- Price, L. C., Daws, T. and Pawlewiz, M., 1986. Organic metamorphism in the Lower Mississippian — Upper Devonian Bakken shales. *J. Petrol. Geol.*, 9(2): 125–162.
- Proshlyakov, B. K., 1974. *Secondary Changes in Oil and Gas Reservoir Rocks*. Nedra Press, Moscow.
- Radlinski, A. P. and Cadman, S. J., 1993. Tilt and drainage ratio in sedimentary basins. *Bull. Am. Assoc. Petrol. Geol.*, 77(1): 19–31.
- Rainwater, F. H. and White, W. F., 1958. The solosphere — its inference and study. *Geochim. Cosmochim. Acta*, 14: 244–249.
- Rakitov, A. I., 1971. *Lecture Course in Logic of Sciences*. Higher Education Publishers, Moscow, 176 pp.
- Rakitov, A. I., 1977. *Philosophic Problems of Science (Systems Approach)*. Mysl' Press, Moscow, 270 pp.
- Rapoport, A., 1969. Different approaches to general theory of systems. *Systems Studies. 1969 Yearbook*. Nauka Press, Moscow, pp. 55–79.
- Ray, M. R., Brashear, J. P. and Biglarbigi, K., 1991. Classification system targets unrecovered U.S. oil reserves. *Oil Gas J.*, 89(39): 89–93.
- Rieke, H. H. III and Chilingarian, G. V., 1974. *Compaction of Argillaceous Sediments. Developments in Sedimentology*, 16. Elsevier, Amsterdam, 531 pp.
- Rodionov, D. A. et al., 1987. *Handbook on Mathematical Methods in Geology*. Nedra Press, Moscow.
- Rohrback, B. G., Peters, K. E. and Kaplan, J. R., 1984. Geochemistry of artificially heated humic and sapropelic sediments. 2. Oil and gas generation. *Bull. Am. Assoc. Petrol. Geol.*, 68(8): 1313–1349.
- Root, D. H. and Attanasi, E. D., 1993. Small fields in the national oil and gas assessment. *Bull. Am. Assoc. Petrol. Geol.*, 77(3): 485–490.
- Root, D. H. and Mast, R. T., 1993. Future growth of known oil and gas fields. *Bull. Am. Assoc. Petrol. Geol.*, 77(3): 479–484.
- Sadovskiy, V. N., 1972. Paradoxes of Systems Thoughts. *Systems Studies. 1972 Yearbook*. Nauka Press, Moscow, pp. 133–146.
- Sadovskiy, V. N., 1974. *Foundations of General Theory of Systems*. Nauka Press, Moscow, 279 pp.
- Samedov, F. I. and Buryakovskiy, L. A., 1956. Chemical composition and origin of formation waters of the Neftyanyye Kamni field. *Trans. Azerbaijan Acad. Sci.*, 12(11): 841–848.
- Samedov, F. I. and Buryakovskiy, L. A., 1962. Gas potential of the Productive Series of the southeastern part of Absheron Archipelago. *Petrol. Geol.*, 5(4): 186–189.
- Samedov, F. I. and Buryakovskiy, L. A., 1966. *Oilfield Hydrogeology of the Absheron Archipelago*. Azerneshr Press, Baku, 228 pp.
- Savchenko, V. P., 1952. On the oil and gas accumulation. *Oil Econ.*, 5: 37–44.
- Savchenko, V. P., 1977. *Formation, Appraisal and Development of Oil and Gas Fields*. Nedra Press, Moscow, 219 pp.
- Sazonova, G. I., 1980. *Relic Structures in Oil's Hydrocarbons of Various Stratigraphic Subdivisions*. Nedra Press, Moscow, pp. 5–31.

- Sakhibgareyev, R. S., 1985. Alteration specifics of carbonate reservoirs in the process of formation and destruction of oil and gas accumulations. In: *Distribution Patterns of Complex Reservoirs and the Forecast of Oil and Gas Potential*. Nauka Press, Leningrad, pp. 85–93.
- Saxby, J. D., 1982. A reassessment of the range of kerogen maturities in which hydrocarbons are generated. *J. Petrol. Geol.*, 5(2): 217–247.
- Scott, A. K., Kaiser, W. R. and Ayess, W. R., 1994. Thermodynamic and secondary biogenic cases, San Juan Basin, Colorado and New Mexico — Implication for producibility of coal beds. *Bull. Am. Assoc. Petrol. Geol.*, 78(8): 1176–1206.
- Seifert, W. K., 1978. Steranes and terpanes in kerogen pyrolysis for correlations of oils and source rocks. *Geochim. Cosmochim. Acta*, 42: 473–484.
- Seifert, W. K. and Moldowan, I. M., 1980. The effect of thermal stress on source rock quality as measured by hopane stereochemistry. *Phys. Chem. Earth*, 12: 229–237.
- Seifert, W. K. and Moldowan, I. M., 1986. Use of biological markers in petroleum exploration. *Biol. Markers Sediment Rec.*, 1: 267–290.
- Sergiyenko, S. I., 1984. Heat field of oil and gas provinces of the USSR. In: *Reference Book of Oil and Gas Geology*. Nedra Press, Moscow, pp. 267–294.
- Sergiyenko, S. I., 1995. Heat flow and HC generation processes. *Trans. Russ. Acad. Sci.*, 217: 949–950.
- Serebrovskaya, K. B., 1986. Possible role of abiogenic oil in the origins of life on the Earth. *ZhVKhO Publishing*, 5: 513–517.
- Serruya, C., Picard, L. and Chilingarian, G. V., 1967. Possible role of electrical currents and potentials during diagenesis (“electrodiagenesis”). *J. Sediment. Petrol.*, June: 695–698.
- Setrov, M. I., 1972. *Foundations of Functional Theory of Organization (Philosophical Essay)*. Nauka Press, Leningrad, 164 pp.
- Shen, R. et al., 1988. Characteristics of isotope composition of gasiform hydrocarbons and identification of coal-type gas: *Sci. Sen. Sem. B.*, 31(6): 737–747.
- Sheriff, R. E., 1984. *Encyclopedic Dictionary of Exploration Geophysics*, 2nd ed.: Society of Exploration Geophysicists, Tulsa, OK.
- Shipov, G. I., 1989. Systematization of relativity principles in physics. *Abstracts of the III All-Union Conference “Systems approach in geology”*, Moscow, pp. 137–139.
- Shvetsov, P. F., 1974. *Geothermal Conditions in Mesozoic-Cenozoic Oil and Gas Basins*. Moscow, Nauka Press, 117 pp.
- Simonenko, V. F., 1988. *Emigration of HC in Water Soluble State and their Initial Accumulation*. Proc. VIEMS, Moscow, 79 pp.
- Sinnokrot, A. A. and Chilingar, G. V., 1961. Effect of polarity of oil and presence on carbonate particles on relative permeability of rocks. *The Compass of Sigma Gamma Epsilon*, 38: 115–120.
- Sinnokrot, A. A., Ramey, H. J. Jr. and Marsden, S. S., 1969. *Effect of Temperature Level upon Capillary Pressure Curves*. SPE paper 2517 presented at 44th SPE of AIME Annual Fall Meeting, Denver, Colorado.
- Smirnov, L. B., 1980. *Heat Field of the USSR Territory*. GUGK, Moscow, 219 pp.
- Smith, O. U., 1954. Studies on origin of petroleum, occurrence of hydrocarbons in recent sediments. *Bull. Am. Assoc. Petrol. Geol.*, 3(8): 377–404.
- Smirnov, Yu. P., 1989. Systems approach to geology. *The III All-Union Conference*, Moscow, pp. 47–53.
- Sokolov, V. A., Bestuzhev, M. A. and Tikhomolova, T. B., 1971. *Chemical Composition of Oil and Natural Gases in Connection with their Origin*. Nedra Press, Moscow, 171 pp.
- Solovyev, N. N., 1986. Tectonic mechanism of degassing the subsurface hydrosphere in gas accumulation formation. *Trans. USSR Acad. Sci.*, 286 (4): 947–950.
- Spencer, C. W., 1987. Hydrocarbon generation as a mechanism for overpressuring in Rocky Mountain region. *Bull. Am. Assoc. Petrol. Geol.*, 71(4): 368–388.
- Stadnikov, G. L., 1931a. *Origin of Coal and Oil*. GONTI, Leningrad, 217 pp.
- Stadnikov, G. L., 1931b. *Origin of Oil and Gas*. The USSR Academy of Sciences Publishing, Moscow, 597 pp.

- Starobinets, I. S., Kondratov, L. S. and Fedorova, G. S., 1986. Role of physical fields in formation of hydrocarbon and geochemical concentration fields in sedimentary rocks. In: *Modeling of Geochemical Field of Oil and Gas Deposits*. Nedra Press, Moscow, pp. 47–54.
- Stefanova, E. I. and Shimorina, E. F., 1981. Study of coal in fault zones. *Geol. Explorat.*, 1: 27–34.
- Strakhov, N. M., 1960. *Foundations of Lithogenetic Theory*. Nauka Press, Moscow, 631 pp.
- Stetyukha, Ye. I., 1964. *Equations of Correlations between Physical Properties of Rocks and Depth of Burial*. Nedra Press, Moscow.
- Sulin, V. A., 1948. *Oilfield Hydrogeology*. Gostoptekhizdat, Leningrad, 245 pp.
- Terzaghi, K., 1961. *Theory of Mechanics of Soils* (translated from German). Gosstroyizdat, Moscow.
- Tkhostov, B. A., 1966. *Initial Reservoir Pressure and Geofluidal Systems*. Nedra Press, Moscow, 268 pp.
- Tissot, B.P. and Welte, D.H., 1978. *Petroleum Formation and Occurrence. A New Approach to Oil and Gas Exploration*. Springer, Berlin-Heidelberg-New York, 538 pp.
- Tissot, B. and Welte, D., 1981. *Oil Generation and Distribution*. Mir Press, Moscow, 273 pp.
- Tissot, B. P., Pelet, R. and Ungeser, P. H., 1987. Thermal history of sedimentary basins, maturation indices and kinetics of oil and gas generation. *Bull. Am. Assoc. Petrol. Geol.*, 71(12): 1445–1466.
- Tolstikhin, N. I., 1932. Toward question of graphical representation of analysis of waters. In: V. Golubyatnikov (Editor), *Sampling of Mineral Deposits*. Gosgeolizdat, Moscow-Leningrad, pp. 1–8.
- Tolstikhin, N. I. et al., 1954. Hydrogeology. In: N. B. Vassoyevich (Ed.), *Companion of Field Petroleum Geologist, Part II*. Gostoptekhizdat, Leningrad, pp. 101–145.
- Trash, P.J. and Brown, K.E., 1965. *Field Operation Handbook for Gas Lift*. Otis Engineering, Dallas, TX, 88 pp.
- Trofimuk, A. A., Karogodin, Yu. N. and Movshovich, E. B., 1980. Problems of improvement in oil and gas geology conceptual and terminology base. *Geol. Geophys.*, 2: 3–10.
- Trofimuk, A. A., Cherskiy, N. V., Tsarev, V. P. and Soroka, G. I., 1981. New data on experimental studies of transformation of organic matter using mechanical forces. *Trans. USSR Acad. Sci.*, 257 (1): 207–211.
- Trofimuk, A. A. et al., 1982. Problems of improvement in oil and gas geology conceptual base. *Geol. Geophys.*, 5: 18–24.
- Tsarev, V. P., 1978. New data on liquid hydrocarbon primary migration mechanism from thinly dispersed media. *Geol. Geophys.*, 7: 15–25.
- Tverdova, R. A. and Eremenko, N. A., 1988. Transformation of kerogen in sedimentary rocks. *Reports on Geochemistry and Chemical and Physical Problems of Exploration and Production of Oil and Gas, vol. 1 — Geochemistry*, Sol'nok. pp. 202–210.
- Tverdova, R. A. and Eremenko, N. A., 1992. Products of transformation of concentrates of insoluble OM of sedimentary rocks. In: *Modeling of Oil and Gas Generation*. Nauka Press, Moscow, pp. 14–18.
- Uyemov, A. I., 1969. Logical analysis of systems approach to objects and its place among the other study techniques. *Systems Studies. 1969 Yearbook*. Nauka Press, Moscow, pp. 80–96.
- Uyemov, A. I., 1978. *Systems Approach and General Theory of Systems*. Mysl' Press, Moscow, 272 pp.
- Urov, K. E., 1992. Saturatedness of oils in light of mechanical destruction of kerogen-containing rocks. In: *Modeling of Oil-Gas Generation*. Nauka Press, Moscow, pp. 125–128.
- Urmantsev, Yu. A., 1974. *Symmetry of the Nature and Nature of the Symmetry (Philosophic and Scientific Aspects)*. Mysl' Press, Moscow, 229 pp.
- Urmantsev, Yu. A., 1978. Fundamentals of the general theory of systems. In: *Systems Analysis and Scientific Knowledge*. Nauka Press, Moscow, pp. 7–41.
- Uspenskiy, V. A., 1970. *Introduction to Geochemistry*. Nedra Press, Leningrad, 164 pp.
- Van Krevelen, D. W., 1961. *Coal. Typology — Chemistry — Physics — Constitution*. Elsevier, Amsterdam, 514 pp.
- Vassoyevich, N. B. (Ed.), 1954. *Companion of Field Petroleum Geologist, Part II*. Gostoptekhizdat, Leningrad, 564 pp.
- Vassoyevich, N. B. and Bronovitskiy, A. V., 1962. Density and porosity of sedimentary rocks. *Proc. VNIGRI*, Issue 190, Leningrad, pp. 478–484.
- Vassoyevich, N. B., Korchagina, Yu. I., Lopatin, N. V. et al., 1969. Oil/gas window. *Herald of Moscow State University, Series 4, Geology*, 6: 67–78.

- Vassoyevich, N. B., 1975. Cycles of deposition, lithogenesis and oil and gas generation: In: *Sedimentary Basins and Their Oil and Gas Content*. Moscow University Publishing, Moscow, 176 pp.
- Vassoyevich, N. B., 1976. Concept of age of oil as related to the stages of its generation. *Sov. Geol.*, 2: 72–78.
- Vassoyevich, N. B. and Neruchev S. G., 1979. *Main Stage of Evolution of Oil Source Rocks and Their Diagnostics*. Proc. VNIGRI, Moscow, 184 pp.
- Vassoyevich, N. B., 1984. Dispersed bitumoids in sedimentary rocks. *Reference Book on Geologic Science and Geography*. Nedra Press, Moscow, pp. 68–98.
- Vassoyevich, N. B., 1986. *Geochemistry of Organic Matter and Origin of Petroleum*. Nauka Press, Moscow, 196 pp.
- Veber, V. V., 1966. *Sedimentary Facies Favorable for Oil Generation*. Nedra Press, Moscow, 121 pp.
- Vennard, J. K., 1961. *Elementary Fluid Mechanics*, 4th ed. Wiley, New York, NY, 570 pp.
- Vernadskiy, V. I., 1975. *Reflections of a Naturalist: Space and Time in Live and Inanimate Nature*. Nauka Press, Moscow, 173 pp.
- Vernadskiy, V. I., 1995. *Live Matter and the Biosphere*. Nauka Press, Moscow.
- Vistelius, A.B., 1980. *Fundamentals of Mathematical Geology*. Nauka, Leningrad.
- Voytov, G. I., 1986. Chemistry and scale of present-day flow of natural gases in different geo-structural zones of the Earth. *ZhVKhO Publishing*, 31(5): 533–540.
- Volkova, I. B., 1990. *Organic Petrology*. Nedra Press, Leningrad, 217 pp.
- Volterra, V., 1976. *Mathematical Theory of Struggle for Survival* (translated from Italian). Nauka Press, Moscow.
- Vorobyev, V. M., 1989. Typology of ideal concepts of geologic objects as systems. *Abstracts of the III All-Union Conference "Systems approach to geology"*, Moscow, pp. 17–18.
- Voropayev, V. N., 1989. Methodological aspects of systems approach to geology. *Abstracts of the III All-Union Conference "Systems approach to geology"*, Moscow, pp. 27–28.
- Von Engelhardt, 1960. *Der Porenraum der Sedimente*. Springer, Berlin, 207 pp.
- Waples, D. W., 1980. Time and temperature in petroleum formation: Application of Lopatin's method to petroleum exploration. *Bull. Am. Assoc. Petrol. Geol.*, 46(6): 916–926.
- Waples, D. W., 1992. The art of maturity modeling, *Parts 1, 2*. *Bull. Am. Assoc. Petrol. Geol.*, 76: 31–60.
- Weber, K. J., 1986. How heterogeneity affects oil recovery. *Reservoir Characterization*. Acad. Press, Orlando, pp. 17–21.
- Weller, F. A., 1959. Compaction of sediments: *Bull. Am. Assoc. Petrol. Geol.*, 43(2): 273–310.
- Welte, D. H., Hagemann, H. W., Hollerbach, A. and Leythausen, D., 1975. Correlation between petroleum and source rocks. *Proc. IX World Petrol. Congr. Panel Discussion*, Tokyo, 3, pp. 179–191.
- Wescott, W. A. and Hood, W. C., 1994. Hydrocarbon generation and migration routes in the East Texas Basin. *Bull. Am. Assoc. Petrol. Geol.*, 78(2): 287–307.
- White, D., 1915. Some relation in origin between coal and petroleum. *Proc. Wash. Acad. Sci.*, 6: 2–21.
- White, D. A., Garrett, R. W., March, G. R. et al., 1975. Assessing regional oil and gas potential. methods of estimating the volume of undiscovered oil and gas resources. *AAPG Studies in Geology*, 1: 143–159.
- White, D. A., 1987. Conventional oil and gas resources. *Resources and World Development*. Wiley, New York, pp.113–128.
- White, L. P., 1981. A play approach to hydrocarbon resource assessment and evaluation. *The Economics of Exploration for Energy Resources*. JAI Press, pp. 51–68.
- Wilhelms, A., Larter, S. R. and Leythaenser, D., 1991. Influence of bitumen 2 on Rock-Eval pyrolysis. *Org. Geochem.*, 17(3): 315–354.
- Yakushin, B. V., 1975. Classification: *Great Soviet Encyclopedia*, 6. Moscow.
- Yermakova, V. I., Sukhoveyeva, G. S. and Baryshnikova, L. P., 1988. Thermobaric destruction of geostructures in bituminous matter — source of HC neoformation. *Primary Migration and Oil and Gas Potential of Sedimentary Basins*. Proc. VNIGNI, Moscow, pp. 27–35.
- Yerzhanov, Zh. S., Yegorov, A. K., et al., 1975. *Theory of Crustal Folding*. Nauka Press, Moscow.
- Zabrodin, V. Yu., 1981. *Systems Analysis of Faults*. Nauka Press, Moscow, 200 pp.

- Zhabrev, I. P., 1993. Geologic concepts and the system of modeling. In: *Problems of Theory and Methodology in Forecasting Oil and Gas Occurrences*. Oil and Gas, Moscow, pp. 39–45.
- Zhdanov, M. A. and Kartsev, A. A., 1958. *Oilfield Geology and Hydrogeology*. Gostoptekhizdat, Moscow, 312 pp.
- Zhel'tov, Yu. P. and Khristianovich, S. A., 1955. On hydraulic fracturing of oil reservoirs. *Proc. USSR Acad. Sci. Sect. Tech. Sci.*, 5: 79–87.
- Zhuze, T. P. and Sushilin, A. V., 1984. Physical and thermodynamic properties of liquid and gaseous HS's at reservoir conditions. *Reference Book of Oil and Gas Geology*. Nedra Press, Moscow, pp. 98–142.
- Zhuze, T. P., 1986. *Hydrocarbon Migration in Sedimentary Rocks*. Nedra Press, Moscow, 117 pp.

Author Index

- Abasov, M.T., 270
 Afanasyev, V.G., 2, 9
 Agamaliyev, R.A., 51, 205, 221
 Akramkhodzhayev, A.M., 124–125,
 129, 131
 Aleksandrov, B.L., 51
 Alekseyev, 128
 Aliyarov, R.Yu., 57
 Allen, J.R., 34–35, 118, 120
 Allen, P.A., 118, 120, 161
 Aminzadeh, F., 51, 53, 64, 171, 177,
 213, 217, 219–221, 226–227,
 257–258
 Amirkhanov, Sh.Kh., 124
 Ammosov, I.I., 50, 117–119, 121–124
 Andreyev, P.F., 120
 Antonellini, M., 27–28
 Arkhangelskiy, A.D, 135–136
 Arkharova, I.M., 51, 221
 Arps, J.J., 74, 165
 Athy, L.F., 253
 Aydin, A., 27–28

 Babalyan, G.A., 73, 234, 291–293
 Babson, E.C., 191
 Bacon, F.O., 7
 Bagir-zadeh, F.M., 164
 Bagrintseva, K.I., 22, 25, 34, 220
 Baird, R.A., 124
 Bakirov, A.A., 20
 Barker, C.E., 121, 124
 Bars, E.A., 82
 Beletskaya, S.N., 72, 80, 82, 152, 155–157,
 160, 168
 Belousov, V.V., 45, 101, 169
 Bezhayev, 238
 Binder, R.C., 278–279
 Bissell, H.J., 262
 Bereto, Ya.A., 42
 Bogomolov, A.I., 120
 Bolshakov, Yu.Ya., 197

 Bonham-Carter, G., 205
 Bordovskiy, O.K., 136
 Botnieva, T.A., 92, 94–95, 97, 138
 Brilling, 137
 Brod, I.O., 35–36, 136–137, 149, 173, 195
 Bronovitsky, 253–254
 Brown, K.E., 92
 Bruce, W.A., 193
 Burlin, Yu.K., 35
 Burst, T.F., 126
 Buryakovskiy, L.A., 2, 8, 14–15, 23, 25, 32,
 44, 51, 53–57, 59–60, 62–64, 75, 152,
 164–166, 171, 177, 205–206, 213–214,
 217, 218–221, 226–227, 234–236, 238,
 244, 248–250, 252, 254, 256–258, 260,
 262–264, 266, 267, 269, 272–273

 Carman, P.C., 220
 Cartmill, J.C., 159
 Chakhmakhchev, V.A., 96, 179
 Chave, K.E., 75
 Chebotarev, I.I., 75
 Chekalyuk, E.B., 155–156
 Chepak, G.N., 142, 167
 Cherskiy, N.V., 120
 Chilingar, G.V., 22–25, 27, 48, 51–55, 59–60,
 63–68, 73–75, 81–82, 87, 92, 110,
 111–112, 144–145, 151, 153, 156–159,
 164, 170–171, 177, 180, 183, 202–203,
 213, 217, 219–221, 226–227, 257–258,
 262, 287, 292, 295
 Chistyakov, K.B., 140, 142
 Christianovich, 140
 Clarke, F.W., 302

 Darwin, Charles, 1
 Daws, T., 121, 143
 De Sitter, L.U., 75, 78
 Degens, E.T., 75
 Descartes, René, 7
 Dickey, P.A., 159

- Dickinson, G., 51, 253
 Diggs, T.N., 23, 47
 Dmitriyevskiy, A.N., 1, 2, 21
 Dobryanskiy, A.F., 120
 Dobrynin, V.M., 29, 30, 32, 45, 51–52,
 252–253
 Doherty, W.T., 90
 Donaldson, E.C., 276–277
 Donofrio, R.R., 199
 Dow, W.G., 50
 Dunan, 53
 Durmishyan, A.G., 253, 255
 Durov, S.A., 75
 Dutton, S.P., 23, 47
 Dzhafarov, I.S., 8, 14–15, 56, 205, 250, 252,
 254, 256–257, 260, 262
 Dzhevanshir, R.D., 5, 8, 14–15, 53–57,
 59–60, 64, 205, 234, 236, 244, 248–250,
 252, 254, 256–257, 260, 262

 Efros, A.L., 158
 Elliot, G.R., 189
 Engelhardt, Von W., 78
 Eremenko, N.A., 24, 25, 30, 36, 46,
 75, 81–82, 87, 92, 110, 124, 128,
 129, 136, 138, 144–145, 151, 153,
 156–159, 164, 167, 170–171, 173,
 180, 198, 202

 Fedorova, G.S., 115, 156, 179
 Fertl, W.H., 51, 62
 Fishbein, Yu.V., 141–142
 Filos, Yu.I., 155
 Foster, J.B., 51, 253
 Fyodorov, S.F., 164

 Galimov, E.M., 145
 Gattenberger, Yu.P., 85, 196
 Geodekian, A.A., 158
 Glesston, 120
 Gontsov, A.A., 145
 Gorrell, H.A., 75
 Gorshkov, V.I., 50, 117–118, 121–124
 Gorskaya, A.I., 125
 Graybill, K.A., 205
 Grechishnikov, N.P., 50, 117–118,
 121–124
 Gretener, P.E., 201

 Grigor'eva, G.F., 141–142
 Gubkin, I.M., 85, 135, 152
 Gussow, W.C., 162–163, 171

 Ham, H.H., 253
 Harbaugh, J.W., 205
 Hedberg, H.D., 253–254
 Hnatiuk, J., 163
 Hoering, T., 104
 Honarpour, M.M., 293
 Hood, W.C., 50–51
 Horsefield, R., 163
 Hosoi, H., 253
 Hubbert, M.K., 201
 Hunt, J.M., 1, 125

 Ignatchenko, N.A., 124, 144
 Illing, L.V., 151

 Jodry, R.L., 74
 Jones, P.H., 26

 Kahn, J.S., 205
 Kalapov, M.U., 124
 Kalinko, M.K., 98–99
 Kaplan, J.R., 120, 132–133, 145
 Karimov, I.A., 124
 Karogodin, Yu.N., 35, 136
 Kartsev, A.A., 128
 Kauffman, M.E., 205
 Kedrov, B.M., 3
 Kerans, C., 25–26
 Kerimov, V.Yu., 13, 56
 Khain, V.Yu., 19, 32
 Khanin, A.A., 23, 32
 Khatskevich, N.E., 238
 Kheirov, M.B., 56–57
 Khilyuk, L.F., 52, 71, 103–104, 171
 Khitarov, N.I., 58
 King, J.G., 199
 Kirshin, A.V., 124, 131
 Klubov, V.A., 151
 Klubova, T.T., 24, 29, 33–34, 43, 48–49,
 137, 159
 Koichi, A., 152
 Komarov, V.E., 7
 Kondratov, L.S., 115, 156, 179

- Kontorovich, A.E., 32, 35, 128, 136, 140,
161, 174, 176–177, 199
- Kosygin, Yu.A., 3, 4, 14
- Kotyakhov, F.I., 25
- Krouse, H.R., 104
- Krejchi-Graf, K., 75
- Kruglikov, N.I., 157
- Krumbein, W.C., 205
- Kulbitskiy, 128
- Kurazhkovskaya, E.A., 8
- Kushnir, M.I., 124, 131
- Kuznetsov, V.G., 32, 35, 45
- Langnes, G.L., 73, 183
- Larskaya, E.S., 131
- Lebedev, L., 110
- Lee, S., 53
- Leverett, M.C., 290
- Lewis, W.B., 290
- Levorsen, A.I., 25, 35, 161, 170, 173,
182
- Lipetskiv, V.F., 44
- Lopatin, N.V., 2, 118, 120–121, 140
- Lucia, F.J., 25–26
- Magara, K., 51, 58, 159, 253
- Maksimov, S.P., 46, 129, 138, 145, 162, 164,
168
- Mannon, R.W., 74, 183
- Marsden, S.S., 281
- Martinelli, J.W., 163
- Masters, I.A., 197
- Mazzullo, S.J., 22–23, 25, 27, 48, 152,
183
- McCammon, R.B., 205
- Meade, R.H., 253
- Mekhtiev, Sh.F., 77
- Mikhailovskiy, G., 135
- Mikhaylov, I.M., 30, 138, 169, 196
- Mileshina, A.G., 98–99
- Milleau, 57
- Miller, R.L., 1, 205
- Minskiy, N.A., 46–48
- Mirchink, M.F., 151, 217
- Molchanov, V.I., 145
- Moore, H., 104
- Moskvin, V.I., 120
- Movshovich, E.B., 35, 136
- Muravyov, I., 284
- Muskat, M., 186
- Namiol, 111
- Nametkin, S.S., 125–126
- Nazarevich, B.P., 137
- Nazarevich, I.A., 137
- Nazarkin, L.A., 136, 153–154, 160
- Nelson, W.L., 93
- Neruchev, S.G., 128, 129, 131, 140,
142, 157
- Nesterov, I.I., 32, 136, 141–142, 145, 161,
174, 176–177
- Olenin, B.V., 151
- Osborne, W.E., 316
- Otis, R.M., 147
- Parker, 156
- Pavlova, 42
- Pawlewiz, M., 121, 143
- Pelet, R., 118
- Perrodon, A., 197
- Peters, K.E., 120, 132–133, 145
- Petrov, A.A., 87–88, 93, 95, 96, 181
- Picard, L., 143
- Plotnikov, A.A., 196
- Polishchuk, Yu.M., 87
- Potonie, H., 132, 135
- Powers, M.C., 41, 152
- Prasolov, E.M., 103, 104–105, 106
- Price, L.C., 50, 118, 120–121, 124,
143, 145
- Proshlyakov, B.K., 253
- Pugin, V.A., 58
- Rainwater, F.H., 75
- Reznikov, A.N., 170
- Rieke, H.H., 22–23, 25, 27, 40, 48,
53, 63, 74, 136, 152, 183, 201,
252–253
- Robertson, J.O., 52, 64, 73, 203
- Rodionov, D.A., 205
- Rogozina, E.A., 128, 131, 140
- Rohrback, B.G., 120, 132–133,
145
- Rubey, W.W., 201
- Rylkov, A.V., 32

- Safonova, G.I., 98–99
 Sakhibgareyev, R.S., 169
 Salmanov, F.K., 32, 136, 161, 174,
 176–177
 Samedov, F.I., 63, 75, 164, 238
 Sariapo, 156
 Savchenko, V.P., 24, 42, 81, 158, 164, 182,
 196
 Saxby, J.D., 50, 122–124
 Schneidermann, N., 147
 Serebryakov, V.A., 30, 51–52, 59, 64, 203
 Sergiyenko, S.I., 45, 154
 Serruya, C., 143
 Shen, R., 104
 Shibaoka, 123
 Shimorina, E.F., 124
 Shpilman, V.I., 145
 Shvetsov, P.F., 120
 Sidorenko, 117
 Simonenko, V.F., 80, 156–157
 Skripka, 111
 Smirnov, L.B., 154
 Sinnokrot, A., 292
 Sokolov, V.A., 44, 128
 Solovyev, N.N., 14, 167
 Soroka, G.I., 120
 Stadnikov, G.L., 145
 Starobinets, I.S., 115, 156, 179
 Stefanova, E.I., 124
 Stetyukha, Ye.I., 254
 Strakhov, N.M., 124, 135–136
 Sudarikov, 168
 Sulin, V.A., 75, 78, 238
 Sultanov, Ch.A., 111
 Sushilin, A.V., 112–113, 115

 Terry, R.D., 48
 Terzaghi, K., 257
 Tiab, D., 276–277
 Tissot, B., 92, 94, 118, 124–125, 130, 132
 Tkhostov, B.A., 138
 Tolstikhin, N.I., 75–76
 Thrash, P.J., 92
 Trofimuk, A.A., 35, 120, 128, 130, 136

 Tsarev, V.P., 80, 120, 157
 Tverdova, R.A., 124, 128

 Ul'yanov, A.V., 19
 Ungeser, P.H., 118
 Urov, K.E., 143
 Uspenskiy, V.A., 131–132, 137, 140

 Van Krevelen, D.W., 118, 120
 Vasilyev, 178
 Vassoyevich, N.B., 75–76, 78, 82,
 117, 121, 126–128, 137–139, 143,
 148, 253, 254
 Vennard, J.K., 278–279
 Vistelius, 316, 321
 Volkova, T.A., 137
 Volterra, V., 251
 Von Engelhardt, W., 217

 Weber, K.J., 1, 35
 Weber, 1, 128
 Weller, F.A., 253–254
 Welte, D., 92, 94, 118, 124–125, 130, 132
 Wescott, W.A., 50–51
 Whalen, H.E., 51, 253
 White, D., 136
 White, W.F., 75
 Witherspoon, P.A., 26
 Wolf, K.H., 40, 152, 262

 Yakovlev, B.M., 30, 138
 Yakushin, B.V., 3
 Yakutsina, V.P., 170
 Yashchenko, I.G., 87
 Yermakova, V.I., 128

 Zaba, J., 90
 Zhabrev, D.V., 238
 Zhabrev, I.P., 143
 Zheltov, Yu.P., 140
 Zhukhovitskiy, A.A., 145
 Zhuze, T.P., 113–115, 137, 157

Subject Index

- adhesion, 275
 abnormality factor, 54
 Abnormally-high formation pressure (AHFP), 43, 52–55, 57, 59, 61, 63, 66, 201, 203
 abnormally-low formation pressures (ALFP), 68
 Absheron Archipelago, Azerbaijan, 213, 227
 Absheron Peninsula and Archipelago, 58, 245
 Absheron Archipelago rocks, 56
 Acheson-Homeglen-Rimbey-Leduc reef trend, 163, 187
 adsorption water, 80
 AHFP, 44, 60, 62, 64, 65, 107
 Alberta, Canada, 37, 191
 algal-lagoonal (sapropelic) oozes, 132
 alginite, 119
 alkalinity, 239, 240
 alkaline waters, 73, 238, 292, 293
 alkane hydrocarbons, 87
 ALFP, 69
 algo-humite, 119
 ammonium, 79
 anaerobic bacteria, 177
 anisotropy, 215, 216, 218
 anisotropy coefficient, 216–217
 anticlinal reservoir, 201
 Anastasyev-Troitsk Field (North Caucasus), 168
 API gravity, 89
 Arbuckle Limestone, 188
 argon, 103
 Arkansas, 188, 193
 aromatic hydrocarbons, 88
 arenes (aromatic hydrocarbons), 87
 Arrhenius equation, 140
 asphaltenes plus resins, 225–226
 Azerbaijan, 225
 Balakhany Formation, 217
 Bazhenov Formation, Russia, 29, 144
 Baku Archipelago, 58, 59, 63, 223, 229, 231, 245
 barium, 79
 basin, 147
 basins underneath the World Ocean, 149
 bentonite, 43
 benzine fraction, 225
 bitumens, 125, 126, 128, 129, 131
 Boltzmann's constant, 210
 boron, 79
 bottom water, 85
 Braden South Field (U.S.), 101
 breakthrough pressure, 182
 bromine, 79
 buoyancy, 107, 160, 200, 161–162, 167, 285
 Buzachi Peninsula (North Caspian, Kazakhstan), 96

 calcium chloride type water, 78
 caprock breakthrough potential, 31
 capillary pressure, 30, 32, 74, 160, 277, 278, 283, 284
 caprocks, 29–33, 150
 capillarity, 275
 capillary water, 80
 carbon dioxide, 236
 carbon isotope composition, 103
 carbonate rocks, 260
 carbonates, 40
 carbonates caprocks, 34
 catagenetically altered crude oils, 97
 catagenetic maturity, 123
 catagenetic stages, 127, 138
 catagenesis, 121, 153
 Caucasus Black Mountains, 81
 chemical composition of oilfield waters, 76, 77, 93
 clarke, 117

- classification of systems, 10, 174, 207
 classification of crude oils, 89, 91, 93, 95, 97, 99
 classification of hydrocarbon accumulations based on phase relationships, 180
 classification of reservoirs, 36
 classification of terrigenous rocks, 245
 classifications of oil and gas accumulations, 173, 175
 classifications of water, 76
 clay content, 49, 220, 230, 233
 closed combination-drive reservoirs, 193
 coefficient of irreversible compaction, 253
 coal maceral evolution, 120
 coal thermolysis, 140
 coalification factors, 121
 coals, 120, 124
 cohesion, 275
 colloidal-emulsion solution, 72
 combination-drive reservoirs, 191, 194
 combustion heating value, 107
 compaction, 39–41, 152, 154, 253, 255–257, 259, 260, 262
 composition of crude oils, 94
 composition of natural gases, 102
 compressibility of natural gases, 107
 condensates, 112–115, 176
 conversion table, 90–91
 concentration barrier, 159
 contact angles, 276, 280, 281, 282, 284
 cosmic origin, 199
 Coulomb's law, 53
 critical-state accumulations, 184, 198
 critical temperature, 113
 critical-state fluid system, 178
 crude oil, 87, 93–94, 97, 98, 230, 232, 241
 crude oil parameters, 230, 231
 cyclic paraffins (naphthenes), 87

 Dashlary Formation, 239
 deductive approach, 4
 demulsification, 156
 density, 22, 24, 94, 166, 228, 232, 234–236, 242, 243, 244, 257
 depth of burial, 252, 254, 258
Desulfovibrio desulfuricans, 79
 differential entrapment, 162, 164
 diffusion, 157

 dispersed, internal phase, 292
 dispersion medium, 292
 dissolution in compressed gases, 157
 Dominikites, Bazhenovites, 127
 Dogger sandstones, 217
 Donyets Basin of Ukraine, 139
 drive mechanism, 183, 185, 187, 189, 191, 193
 dynamic geologic models, 250
 dynamic geologic systems, 13, 249, 251, 253, 255, 257, 259, 261, 263, 265, 267, 269, 271
 dynamic model, 268
 dynamic viscosity, 244, 247

 Eastern Pre-Caucasus (Russia), 168, 240
 edge water, 182
 effective/phase permeability, 289
 elastic forces, 167
 electrodiagenesis, 143
 elision basins, 82
 Emba Area (Russia), 126
 emulsions, 156
 energy in the oil generation, 141, 143, 145
 energy of organic matter, 143
 entropy, 210–215
 endothermal reactions, 141
 Entrada Sandstone, UT, USA, 28
 epigenesis, 29
 eruptions, 171
 evaporite seals, 34
 Excelsior Field, Alberta, Canada, 190
 exinite, 123
 exothermal reactions, 141
 expulsion of oil, 152

 factors determining the degree of compaction, 261
 faults, 182
 field, 198, 199
 film-type migration, 157
 formal logic, 3, 5
 formation, 19
 formation water, 86, 237–238
 formation volume factor (FVF), 71
 fractures, 25–26, 30

 gas accumulations, 175
 gas column, 108

- gas density, 106
 gas migration, 286
 gas solubility in oil, 177
 gas viscosity, 109
 gas-cap drive, 187, 188
 gas-condensate accumulations, 176
 gas-hydrate, 110
 genetic potential, 131
 genetic types of crude oils, 95, 96
 geologic system, 15, 205
 geochemical classification of crude oils, 97
 geosystem identification, 12
 geothermal gradient, 59
 Gippsland and Cooper basins of Australia, 124
 Goldsmith San Andres Dolomite Pool in West Texas, 187, 188
 grain-to-grain stress, 65
 gravity-drainage, 191, 192
 gravity segregation of oil and gas, 187
 gravitational force, 161
 gravity water, 80

 H₂S content, 103
 hard water, 73, 239, 292
 helium, 103
 He/Ar ratio, 105
 heat conductivity, 45, 71
 heavy-mineral content, 243
 Helium–Argon Technique, 170
 Henry's law, 178
 heterogeneity, 154, 212–213, 215
 heterogeneity entropy, 214
 hierarchical classification, 6
 huminite, 119
 hydrate formation, 109
 hydraulically trapped oil and gas accumulations, 196
 hydraulic forces, 196
 hydraulic fracturing, 44, 182
 hydrocarbon gases, 110
 hydrocarbon reserves, 266
 hydrofracturing, 140
 hydrogen, 103
 hydrogen sulfide geochemical facies, 136
 hydrodynamic systems, 167
 hydrogen isotopes, 75

 hypergenetically altered crude oils, 97
 hypergenetic alteration, 98

 inductive approach, 4
 Inert gases, 105
 infrared spectroscopy, 98
 intensity of subsidence, 265
 inertinite, 119
 interohuminite, 119
 intuitive systems approach, 1
 infiltration drive, 81–82
 interfacial tension, 45, 280
 intermediate water, 86
 irreducible water, 277
 Ishimbay group of fields, 37
 isotope composition of natural gases, 103, 105
 isotope composition of water, 75
 Izbaskent Field, 114

 Jamin effect, 160, 284

 Kala Formation, 214, 255
 Karachukhur–Zykh–Gousany–Gum Deniz–Turkyany anticlinal trend, 214
 kerogen, 118, 125, 126, 130–131, 141
 kinematic viscosity, 244, 247–249
 Kozeny–Carman equation, 220

 lateral migration, 161
 Leduc D-3 Pool, 193
 lipid compounds, 125
 liptinite, 119, 124
 lithite, 241
 lithofacies, 19
 lithofluidal system, 208
 lithogenesis, 121
 Lopatin's technique, 118
 lower edge water, 85
 Lower Kura Depression, 58–59, 63, 222, 223, 229, 231
 lower water, 86

 magnesium chloride type water, 78
 main phase of oil and gas generation, 129
 massive reservoirs, 37, 38
 mathematical simulation, 209

- Maykop Formation (Krasnodar Region, Russia), 85
 mesocatagenetic zone, 139
 methane, 236
 methane–water system, 111
 microcomponents of coals, 119
 microoil, 137
 migration-altered crude oils, 99
 Milk River Field (Canada), 197
 mixed base crude oil, 89
 model of organism growth, 256
 model of proportional effect, 251
 modeling coefficients, 260
 modeling in geology, 14
 molecular solubility, 156
 monoclines, 196–197
 montmorillonite, 24, 58–59, 63–64, 222, 225
 montmorillonite-to-illite transformation, 46, 57
 Mount Holly Pool, 193
 multidimensional models, 240

 naphthenes, 88
 naphthenic or asphaltic base crude oils, 89
 natural gases, 101, 236
 Neft Dashlary Formation, 225, 239
 Neft Dashlary Oilfield, 225, 226, 238
 nitrogen, 104
 nitrogen content in gases, 101
 nomogram, 246, 254
 non-polar oil, 291
 normalization equations, 260
 normalization for natural factors, 262
 normalized pressure, 84

 oceanic environment, 150
 offshore formations in Azerbaijan, 267, 272
 oil and gas province, 151
 oil window, 140
 oil/water mobility, 271
 oilfield waters, 77
 oligomictic, 221
 open combination-drive reservoirs, 191, 193
 Ordovician, 199
 organic matter (OM), 117, 119, 121–123, 125, 127
 organic theory of oil generation, 135
 organo-fluidoliths, 117
 orthogonal and conjugated regression, 235
 orthogonal regression, 234
 osmosis, 65, 67–69
 overburden pressure, 153
 overpressure, 51
 OWC, 73, 83–84
 oxidation, 48
 oxidation/reduction potential, 47
 oxygen isotopes, 75

 parameter, A_{da} , 223
 paleotemperature, 49–50
 Palmer's characteristics, 241
 Palvantash and Izbasket fields of the Fergana Basin (Uzbekistan), 112
 paraffin base crude oil, 89
 paraffin/naphthene ratio, 92
 permafrost, 67
 permeability, 22–23, 27, 39, 49, 215, 216, 218, 220, 230, 263, 269, 289
 petroleum geology systems, 209
 pH, 71
 pH stability limits, 48
 phase transformation, 112–113, 115
 piezometric surface, 83
 pinch-out pressure, 182
 plate tectonics, 148
 play, 147, 148
 Poisson's ratio, 39
 polar oil, 291, 292, 293
 polar substances, 73
 porosity, 21, 27, 39, 220, 254, 258, 269
 porosity of shales, 251, 253
 potential energy, 31
 pore-fluid pressures, 60, 268, 270, 271
 pore pressure, 54, 153–154, 270
 pore-pressure gradient, 55, 59
 prediction of rock properties, 264
 Priazov Series (Ukrainian Shield), 117
 primary gas-condensate, 116
 primary migration, 151, 152, 157, 160
 probabilistic-statistical models, 221
 Productive Series of Azerbaijan, 57, 61, 217, 221–222, 230, 233
 productivity, 74
 prospect, 148

- radioactivity of water, 72
 Rainbow Oilfield, 37
 ratio [odd *n*-alkanes/even *n*-alkanes], 130
 reserves evaluation, 266
 residual water saturation, 269
 Red Wing Creek Field, 199
 Redwater Field, Alberta, Canada, 191, 193
 Red-Bed Series of Turkmenistan, 268
 relative permeability, 74, 289, 291–292
 relative permeability curves, 73
 reservoir rocks, 20–21, 23, 25, 27
 reservoirs, 35, 37
 resins plus asphaltenes, 226, 246
 retrograde evaporation, 113
 Reynolds number, 23
 rock dilatancy, 65, 69
 Romashkino Field, Russia, 165
- Sakhalin Island, 126
 salinity, 64, 75
 salt deformation, 42
 San Juan Field in Alberta, Canada, 85
 sapropelic matter, 135
 saturation pressure technique, 171
 scanning electron microscope (SEM), 57
 Schuler Jones Sand Pool, 189
 secondary migration, 151, 158, 161
 sedimentogenesis, 139
 seismic data, 52
 set, 5
 Siberian Platform, 117
 Slaughter San Andres Limestone Pool, 185
 Smackover Limestone, 188, 189
 Smackover Oolite Limestone, 193
 solution gas drive, 184–185, 186
 sodium bicarbonate type of waters, 78
 sodium sulfate type of waters, 78
 solubility isotherms of normal paraffin hydrocarbons in methane, 115
 solubility of gases in water, 110
 solubility of hydrocarbon gases in crude oils, 111
 source rocks, 137, 158
 South Absheron Offshore Zone, 229, 231
 South Caspian Basin, 53, 55, 58, 62, 64, 200, 217, 238, 267, 270
 South Semivodskoe gas-condensate field (West Siberia), 101
- specific gravity of gas, 237
 specific pore surface area, 21, 25, 219–220
 stages of oil and gas generation, 139
 stagewise transformation of organic matter, 138
 static geologic systems, 208, 211, 213, 215, 217, 219, 221, 223, 225, 227, 229, 231, 233, 235, 237, 239, 241, 243, 245, 247
 static system, 13
 stereochemical studies, 88
 stress vs. strain, 42
 structural element, 200
 structural maps, 268
 sulfur, 94, 104
 superdeep wells, 179
 surface activity parameters, 224, 229–230, 233
 surface tension forces, 278
 surfactants, 72
 sylvite (KCl), 63
 synclines, 197
 system, 2, 10, 11, 207
 Systems Approach, 8–9, 11, 13, 15, 17, 206
- taphrogene, 149
 tectonic characteristics, 199
 temperature, 42–43, 154
 Tengiz Field, Kazakhstan, 37
 ternary mixtures (water, oil, and gas), 290
 theory of information, 210
 thermodynamic alterations, 142
 thermal diffusion, 158
 three-phase flow, 290
 tilted water–oil contacts, 165, 174
 time factor, 14
 time of formation of hydrocarbon accumulation, 169
 total energy, 7
 total organic carbon (TOC), 117
 tortuosity, 220
 total overburden load, 65
 transformation index, 130
 trap, 36, 173, 174
 trap classifications, 173, 174, 194
 trapped oil globule, 283
 Travis Peak Formation, Texas, 47

- trend, 147
- two-branch capillary, 282
- types of solutions, 11

- upper water, 85, 86

- vertical zonation, 198, 201–202
- viscosity, 110
- vitritinite, 124
- vitritinite reflectance, 50, 121–122
- volatile coalification products, 132
- Volga-Ural Province, 82
- volumetric technique, 170
- vugs, 22, 285

- water, 71, 72, 238
- water drive, 188, 189–190

- water block, 285
- water chemistry, 62–63, 75
- water density, 75
- water – oil mixture, 92
- water-drive pool, 190
- water drive systems, 80, 83
- water origin, 75
- West Texas, 185, 188
- wettability, 275–276
- width of fracture, 26
- World Ocean, 83

- Young's modulus, 44

- zero energy surface, 83
- zonation of oil and gas generation, 128